

Arinc 600 Aerospace Standard Rectangular Avionics Connectors

- Signal, power, databus and coaxial contacts
- Pin size/current: size 22, 20, 16 and 12 contacts have 5A, 7.5A, 13.0A and 23.0A current rating respectively
- Approvals: conforms to MIL-C-81659 B, BACC 66 specifications
- Custom filtering and lightning protection

Technical Characteristics

PERFORMANCE SPECIFICATION																
Dielectric withstanding voltage (DWV)	1500 V rms 500 V rms @ 50,000 ft (15,240 m)															
Contact continuous current ratings	Size 22 - 5.0A ; Size 20 - 7.5A Size 16 - 13.0A ; Size 12 - 23.0A															
Contact resistance (max):	<table border="1"> <thead> <tr> <th></th> <th>Initial</th> <th>After conditioning</th> </tr> </thead> <tbody> <tr> <td>Size 22</td> <td>8.0 mΩ</td> <td>1.0 mΩ</td> </tr> <tr> <td>Size 20</td> <td>7.0 mΩ</td> <td>8.5 mΩ</td> </tr> <tr> <td>Size 16</td> <td>3.5 mΩ</td> <td>5.0 mΩ</td> </tr> <tr> <td>Size 12</td> <td>2.0 mΩ</td> <td>2.5 mΩ</td> </tr> </tbody> </table>		Initial	After conditioning	Size 22	8.0 mΩ	1.0 mΩ	Size 20	7.0 mΩ	8.5 mΩ	Size 16	3.5 mΩ	5.0 mΩ	Size 12	2.0 mΩ	2.5 mΩ
	Initial	After conditioning														
Size 22	8.0 mΩ	1.0 mΩ														
Size 20	7.0 mΩ	8.5 mΩ														
Size 16	3.5 mΩ	5.0 mΩ														
Size 12	2.0 mΩ	2.5 mΩ														
Insulation resistance	5.0 GΩ min. @ 500 Vdc															
Engagement / separation force	Shell size 1 - 27 lbs (120N) max Shell size 2 - 60 lbs (267N) max Shell size 3 - 105 lbs (467N) max															
Mechanical endurance	500 cycles min - mating and unmating															
Temperature range	-65 deg C to + 125 deg C															
Fluid immersion resistance (Class E only)	(1) Hydraulic fluid to Mil-PRF-5606 (2) Lubricating oil (synthetic) to Mil-PRF-23699 (3) 1:3 mix of isopropyl alcohol and mineral spirits per FED, SPEC TT-I-735 and TT-T291 respectively															
Shock	MIL-Std-1344, method 2004.1, test condition A: Three shocks in each direction along each of 3 axes, mutually perpendicular to each other. No visible damage, breakage, cracking or loosening of parts and no electrical discontinuities exceeding 1 micro-second															
Vibration	Mil - Std-1344, method 2005.1, condition value E, random - 16.4g minimum severity, 8 hours in each of 3 mutually perpendicular planes with 100 mA electrical load. No visible damage, breakage, cracking or loosening of parts, and no electrical discontinuities exceeding 1 micro-second															

MATERIAL SPECIFICATION	
Shells	Aluminium alloy electroless nickel plate
Retaining plates	Aluminium alloy electroless nickel plate
Polarising posts/keys	Post – Stainless Steel passivated Keys – Aluminium Alloy, Alodine 1200
Inserts	Glass filled epoxy
Inserts (metallic)	Aluminium alloy electroless nickel plate
Fixing screws and washers	Stainless steel, passivated
Contact bodies	Copper alloy, gold over nickel
Contact retention clips	Beryllium copper
Seals and grommets	Fluorosilicone elastomer to Mil-R-25988
EMI springs	Beryllium copper
Protection covers	Conductive Polymer

Ordering Information

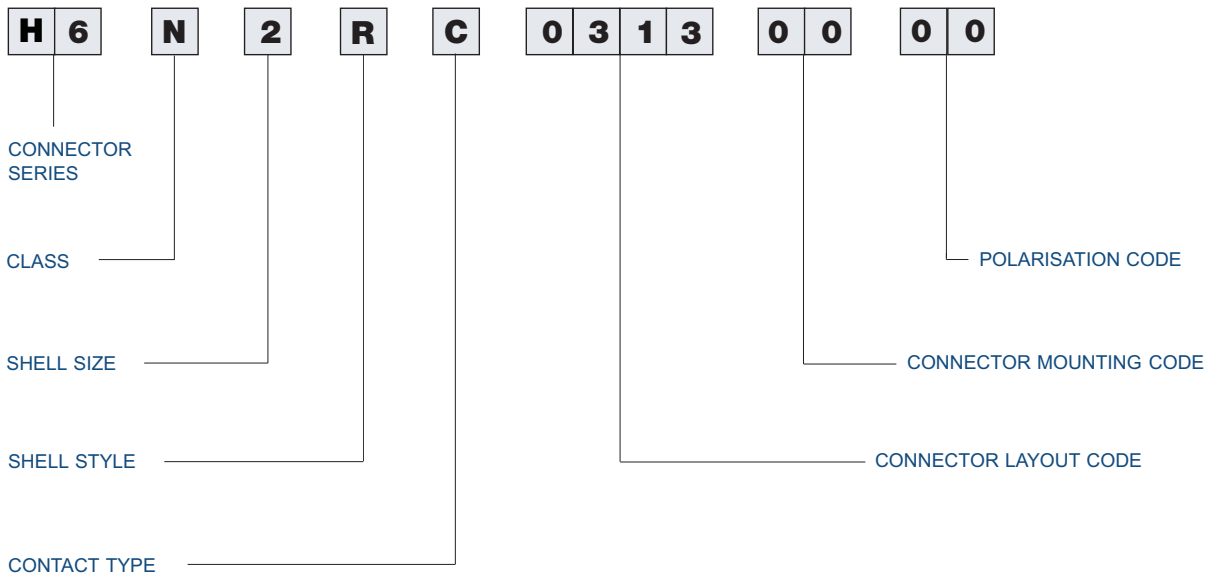

CONNECTOR SERIES
H6 signifies Hypertac Arinc 600 series

CLASS
N - Non environmental (rear release, crimp contacts)
E - Environmental (rear release crimp contacts)
F - Non-environmental front release size 22 socket contacts (pc tail or wire wrap), crimp rear release all other contact sizes. This version available for receptacle only.

SHELL SIZE
1 - maximum contact capacity 160
2 - maximum contact capacity 400
3 - maximum contact capacity 800

SHELL STYLE
P - plug
R - receptacle (note: receptacle has size 22 signal sockets contacts, and pin contacts for all other contact sizes. Plug connector is the reverse of this).

CONTACT TYPE
X- No contacts supplied
C - Rear release crimp (signal & power) contacts supplied with connector
P - Front release pc tail (L = 2.92 mm nom) size 22 socket contact installed in connector.
Q - Front release pc tail (L = 3.81 mm nom) size 22 socket contact installed in connector.
R - Front release pc tail (L = 6.35 mm nom) size 22 socket contact installed in connector.
S - Front release pc tail (L = 9.35 mm nom) size 22 socket contact installed in connector.
T - Front release pc tail (L = 12.7 mm nom) size 22 socket contact installed in connector.
V - Front release wire wrap (L = 2 wraps mm nom) size 22 socket contact installed in connector.
W - Front release wire wrap (L = 3 wraps mm nom) size 22 socket contact installed in connector.
Z - Front release wire wrap (L = 1 wrap mm nom) size 22 socket contact installed in connector.

Power pin contacts, crimp rear release, supplied uninstalled
Power pin contacts, crimp rear release, supplied uninstalled
Power pin contacts, crimp rear release, supplied uninstalled
Power pin contacts, crimp rear release, supplied uninstalled
Power pin contacts, crimp rear release, supplied uninstalled
Power pin contacts, crimp rear release, supplied uninstalled
Power pin contacts, crimp rear release, supplied uninstalled
Power pin contacts, crimp rear release, supplied uninstalled
Power pin contacts, crimp rear release, supplied uninstalled

NOTE:
Coaxial, Triaxial, and Twinaxial contacts should be ordered separately

CONNECTOR LAYOUT CODE
The most popular insert arrangements are detailed below for shell sizes 1, 2, and 3.
For availability of other contact arrangements consult Hypertac Ltd. Sales Office.

Connector layout code

Connector layout Code	Shell size	Shell cavity identification		
		A	B	C
0005	1	Blank	Blank	5W2
0060	1	Blank	60	Blank
A060	1	60	Blank	Blank
0065	1	Blank	60	5W2
A065	1	60	Blank	5W2
0120	1	60	60	Blank
0125	1	60	60	5W2
0160	1	60	60	40
0013	2	Blank	Blank	13W2
0100	2	Blank	Blank	100
0133	2	60	60	13W2
0137	2	121	10T10	6T6
T141	2	120T2	10T10	13W2
0150	2	Blank	150	Blank
A150	2	150	Blank	Blank
0163	2	Blank	150	13W2
A163	2	150	Blank	13W2
0173	2	150	10T10	13W2
A173	2	10T10	150	13W2
0215	2	121	60	34
0221	2	121	Blank	100
0233	2	150	60	13W2
0244	2	150	60	34
0246	2	120T2	120T2	6T6
0248	2	121	121	6T6
0250	2	Blank	150	100
250A	2	150	Blank	100
0253	2	120T2	120T2	13W2
0275	2	121	60	34
0284	2	150	121	13W2
0300	2	150	150	Blank
0305	2	150	121	34
0306	2	150	150	6T6
0313	2	150	150	13W2
0334	2	150	150	34
0340	2	120T2	120T2	100
0370	2	150	120T2	100
A370	2	120T2	150	100
0400	2	150	150	100

Connector layout code

Connector layout Code	Shell size	Shell Cavity identification					
		A	B	C	D	E	F
0026	3	Blank	Blank	13W2	Blank	Blank	13W2
0113	3	Blank	Blank	100	Blank	Blank	13W2
A113	3	Blank	Blank	13W2	Blank	Blank	100
0231	3	121	10T10	100	Blank	Blank	Blank
0263	3	Blank	Blank	13W2	Blank	150	100
313A	3	150	Blank	13W2	150	Blank	Blank
0326	3	Blank	150	13W2	Blank	150	13W2
0434	3	150	150	Blank	121	Blank	13W2
0437	3	150	150	6T6	121	10T10	13W2
0444	3	150	121	13W2	150	10T10	Blank
0450	3	150	150	6T6	121	10T10	13W2
0463	3	150	Blank	13W2	150	150	Blank
0494	3	121	120T2	6T6	121	120T2	6T6
0496	3	121	121	6T6	121	121	6T6
0510	3	121	121	13W2	121	121	13W2
0550	3	150	150	100	150	Blank	Blank
0552	3	121	121	34	121	121	34
0563	3	Blank	150	100	150	150	13W2
0600	3	150	150	Blank	150	150	Blank
0608	3	120T2	150	34	120T2	150	34
0613	3	150	150	13W2	150	150	Blank
0620	3	150	60	100	150	60	100
A620	3	150	150	100	60	60	100
0626	3	150	150	13W2	150	150	13W2
0668	3	150	150	34	150	150	34
0713	3	150	150	100	150	150	13W2
A713	3	150	150	13W2	150	150	100
0734	3	150	150	100	150	150	34
0742	3	121	150	100	121	150	100
0800	3	150	150	100	150	150	100

Connector mounting code

- 00 – Standard design 3.76 mm dia. holes
- 01 – With 6-32 ESNA (12NCFMA2-62) clinch nuts (see table below)
- 02 – Size 1 receptacle only - less 3 printed circuit mounting lugs
- 03 – with 4-40 ESNA (NCFMA-2-40) clinch nuts (see table below)
- 08 – size 2 and 3 plug and receptacle only - with 4-40 ESNA (22NCFMA2-40) clinch nuts (all mounting holes)
- 09 – size 2 and 3 plug and receptacle only - with 6-32 ESNA (12NCFMA-2-62) clinch nuts (all mounting holes)
- 23 – with floating eyelets 1.2mm min. radial float, 4 corner holes per connector

Shell size	Quantity of clinch nuts Plug Connector	Quantity of clinch nuts Receptacle Connector
1	4	4
2	4	6
3	8	10

Consult Hypertac Sales Office for alternative connector mounting codes

Polarisation code

- 01 to 99 inclusive. See listing of available keying positions in dedicated table
- 00 – Polarisation hardware supplied loose with connector

Inserts for cavities A & B

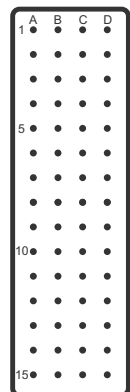

Insert 60
(60) Size 22 Contacts

Blank

Inserts for cavities C

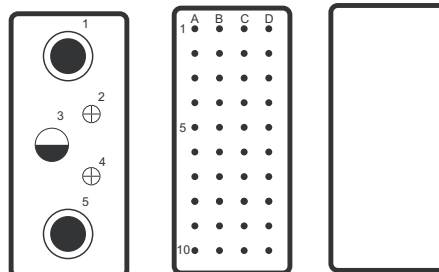

Insert 5W2
(2) Size 16 Contacts (40) Size 22 Contacts
(1) Size 12 Contact
(2) Size 5 Coax Contacts

Blank

Contact legend

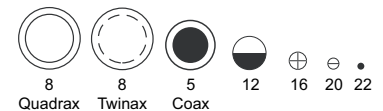

As viewed from mating face of receptacle connector

For other inserts, please consult Hypertac sales office

Contact arrangements shell size 2 & 3

**Inserts for Cavities A & B Shell Size 2
Inserts for Cavities A, B, D & E Shell Size 3**

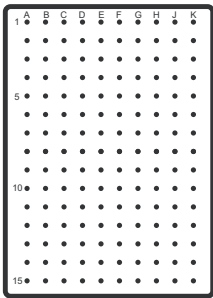

Insert 150
(150) Size 22 Contacts

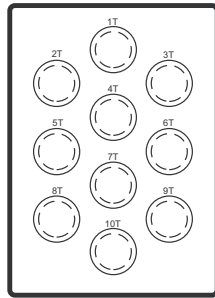

Insert 10T10
(10) Size 8 Twinax, Triax, or Coax Contacts

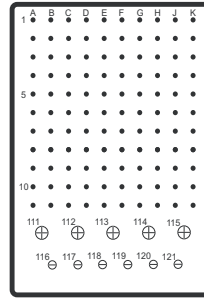

Insert 121
(110) Size 22 Contacts
(6) Size 20 Contacts
(5) Size 16 Contacts

Contact legend

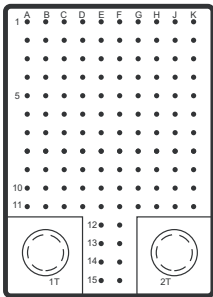
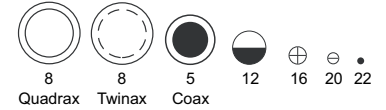

Insert 120T2
(118) Size 22 Contacts
(2) Size 8 Twinax Contacts



Blank

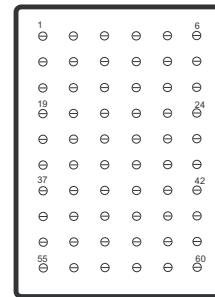

Insert 60
(60) Size 20 Contacts

As viewed from mating face of receptacle connector

For other inserts, please consult Hypertac sales office

**Inserts for Cavities C Shell Size 2
Inserts for Cavities C & F Shell Size 3**

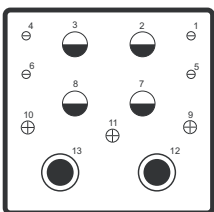

Insert 13W2
(4) Size 12 Contacts
(3) Size 16 Contacts
(5) Size 20 Contacts
(2) Size 5 Coax Contacts

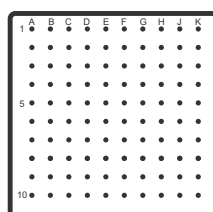

Insert 100
(100) Size 22 Contacts

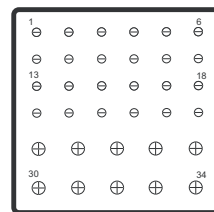

Insert 34
(24) Size 20 Contacts
(10) Size 16 Contacts

Contact legend

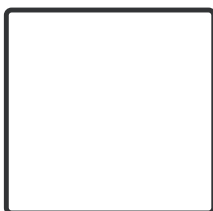
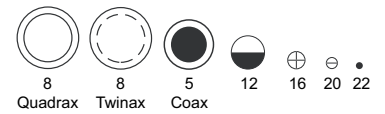

Blank

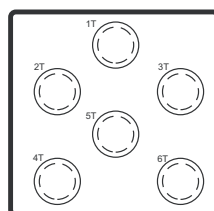

Insert 6T6
(6) Size 8 Twinax, Triax, or Coax contacts

As viewed from mating face of receptacle connector

For other inserts, please consult Hypertac sales office

Quadrax insert arrangements

Size 8 Quadrax

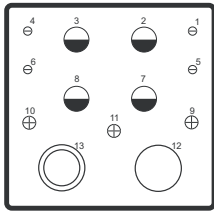

11Q2

- (4) Size 20
- (3) Size 16
- (4) Size 12
- (2) Size 8

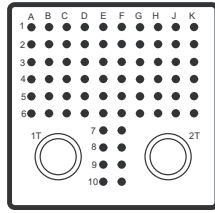

68Q2

- (68) Size 22
- (2) Size 8

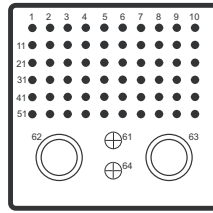

62Q2

- (60) Size 22
- (2) Size 16
- (2) Size 8

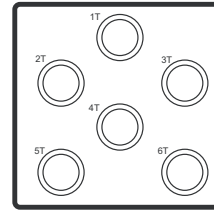

Q6

- (6) Size 8
- Metallic Insert

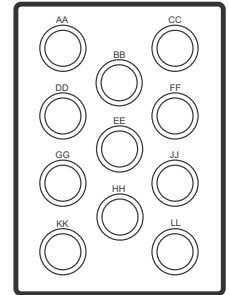

11

- (11) Size 8
- Metallic Insert

Contact legend

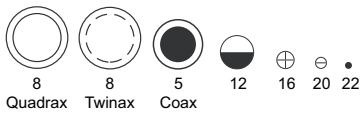

As viewed from mating face of receptacle connector

For other inserts, please consult Hypertac sales office

Polarisation codes

Table 1

PLUG				REC				PLUG				REC			
Position	Left Post	Centre Post	Right Post	Position	Left Post	Centre Post	Right Post	Position	Left Post	Centre Post	Right Post	Position	Left Post	Centre Post	Right Post
00	-	-	-	00	-	-	-	50	2	2	5	50	6	3	3
01	1	1	1	01	4	4	4	51	3	2	5	51	6	3	2
02	2	1	1	02	4	4	3	52	4	2	5	52	6	3	1
03	3	1	1	03	4	4	2	53	5	2	5	53	6	3	6
04	4	1	1	04	4	4	1	54	6	2	5	54	6	3	5
05	5	1	1	05	4	4	6	55	1	2	4	55	1	3	4
06	6	1	1	06	4	4	5	56	2	2	4	56	1	3	3
07	1	1	6	07	5	4	4	57	3	2	4	57	1	3	2
08	2	1	6	08	5	4	3	58	4	2	4	58	1	3	1
09	3	1	6	09	5	4	2	59	5	2	4	59	1	3	6
10	4	1	6	10	5	4	1	60	6	2	4	60	1	3	5
11	5	1	6	11	5	4	6	61	1	2	3	61	2	3	4
12	6	1	6	12	5	4	5	62	2	2	3	62	2	3	3
13	1	1	5	13	6	4	4	63	3	2	3	63	2	3	2
14	2	1	5	14	6	4	3	64	4	2	3	64	2	3	1
15	3	1	5	15	6	4	2	65	5	2	3	65	2	3	6
16	4	1	5	16	6	4	1	66	6	2	3	66	2	3	5
17	5	1	5	17	6	4	6	67	1	2	2	67	3	3	4
18	6	1	5	18	6	4	5	68	2	2	2	68	3	3	3
19	1	1	4	19	1	4	4	69	3	2	2	69	3	3	2
20	2	1	4	20	1	4	3	70	4	2	2	70	3	3	1
21	3	1	4	21	1	4	2	71	5	2	2	71	3	3	6
22	4	1	4	22	1	4	1	72	6	2	2	72	3	3	5
23	5	1	4	23	1	4	6	73	1	3	1	73	4	2	4
24	6	1	4	24	1	4	5	74	2	3	1	74	4	2	3
25	1	1	3	25	2	4	4	75	3	3	1	75	4	2	2
26	2	1	3	26	2	4	3	76	4	3	1	76	4	2	1
27	3	1	3	27	2	4	2	77	5	3	1	77	4	2	6
28	4	1	3	28	2	4	1	78	6	3	1	78	4	2	5
29	5	1	3	29	2	4	6	79	1	3	6	79	5	2	4
30	6	1	3	30	2	4	5	80	2	3	6	80	5	2	3
31	1	1	2	31	3	4	4	81	3	3	6	81	5	2	2
32	2	1	2	32	3	4	3	82	4	3	6	82	5	2	1
33	3	1	2	33	3	4	2	83	5	3	6	83	5	2	6
34	4	1	2	34	3	4	1	84	6	3	6	84	5	2	5
35	5	1	2	35	3	4	6	85	1	3	5	85	5	2	4
36	6	1	2	36	3	4	5	86	2	3	5	86	5	2	3
37	1	2	1	37	4	3	4	87	3	3	5	87	6	2	2
38	2	2	1	38	4	3	3	88	4	3	5	88	6	2	1
39	3	2	1	39	4	3	2	89	5	3	5	89	6	2	6
40	4	2	1	40	4	3	1	90	6	3	5	90	6	2	5
41	5	2	1	41	4	3	6	91	1	3	4	91	1	2	4
42	6	2	1	42	4	3	5	92	2	3	4	92	1	2	3
43	1	2	6	43	5	3	4	93	3	3	4	93	1	2	2
44	2	2	6	44	5	3	3	94	4	3	4	94	1	2	1
45	3	2	6	45	5	3	2	95	5	3	4	95	1	2	6
46	4	2	6	46	5	3	1	96	6	3	4	96	1	2	5
47	5	2	6	47	5	3	6	97	1	3	3	97	2	2	4
48	6	2	6	48	5	3	5	98	2	3	3	98	2	2	3
49	1	2	5	49	6	3	4	99	3	3	3	99	2	2	2

Notes:

Darkened portion indicates extended part of polarisation key in plug; light portion indicates keyway in receptacle. (As viewed from mating face with cavity "A" uppermost)

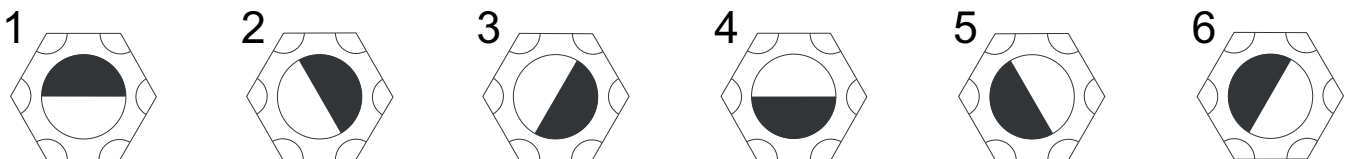

Contact data

Contacts for Hypertac Arinc 600 Rack and Panel Connectors may be ordered separately.

Use the part numbers shown in the tables below for ordering contacts.

Power/signal contacts, crimp rear release

Contact Size	Hypertac P/No Pin	Hypertac P/No Skt	Insertion Tool	Extraction Tool	Crimping Tool	Crimping Positioner	Wire AWG
22	HCM-158-14-53	HCM-147-14-53	M81969/1-01	M81969/1-01	M22520/2-01	M22520/2-23	22,24,26
20	HCM-159-14-23	HCM-155-14-23	M81969/1-02	M81969/1-02	M22520/2-01	M22520/2-08	20,22, 24
16	HCM-202-14-63	HCM-171-14-63	M81969/1-03	M81969/1-03	M22520/1-01	M22520/1-02	16,18,20
12	HCM-200-14-43	HCM-201-14-43	-	M81969/28-02	M22520/1-01	M22520/1-02	12,14

Front release wire wrap socket contacts

Contact Size/Type	Hypertac Part Number
22 Socket – Wire Wrap (1) L = 6.35 mm	HCM-290-14-53
22 Socket – Wire Wrap (2) L = 9.52 mm	HCM-291-14-53
22 Socket – Wire Wrap (3) L = 12.70 mm	HCM-292-14-53

Front release pc tail socket contacts

Contact Size/Type	Hypertac Part Number
22 Socket – PC Tail 2.92 mm nom. post extension	HCM-285-14-53
22 Socket – PC Tail 3.81mm nom. post extension	HCM-286-14-53
22 Socket – PC Tail 6.35mm nom. post extension	HCM-287-14-53
22 Socket – PC Tail 9.52mm nom. post extension	HCM-288-14-53
22 Socket – PC Tail 12.70mm nom. post extension	HCM-289-14-53

Extraction tool for size 22 front release wire wrap or pc tail socket contact is HTA-120-22

Coax, triax, concentric twinax and quadrax contacts

Size 16 Coax Pin

Part number	Cable
HCT-416	RG-178
HCT-417	RG-316

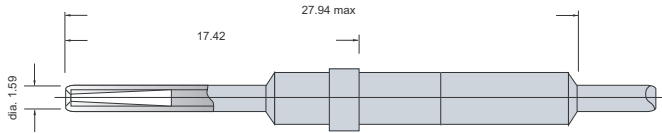

Size 16 Coax Socket

Part number	Cable
HCT-418	RG-178
HCT-419	RG-316

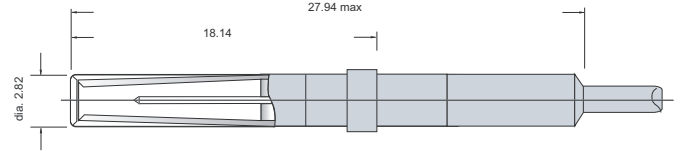

Size 12 Coax Pin

Part number	Cable
HCT-420	RG-178
HCT-421	RG-316

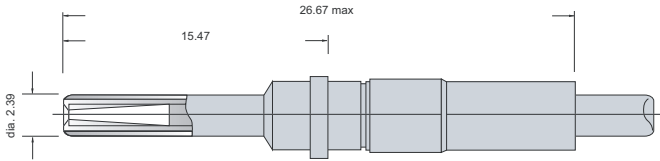

Size 12 Coax Socket

Part number	Cable
HCT-422	RG-178
HCT-423	RG-316

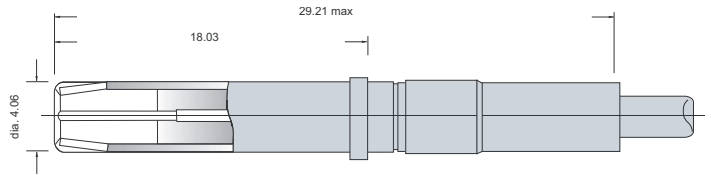

Size 8 Quadrax Pin

Part number	Cable
HCT-424	Consult Hypertac Sales Office

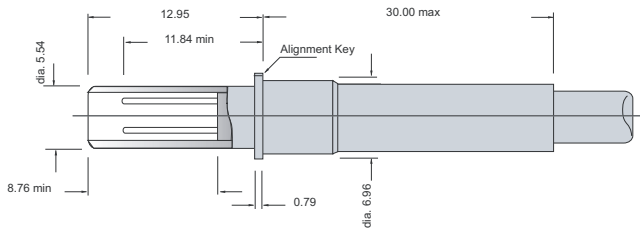

Size 8 Quadrax Socket

Part number	Cable
HCT-425	Consult Hypertac Sales Office

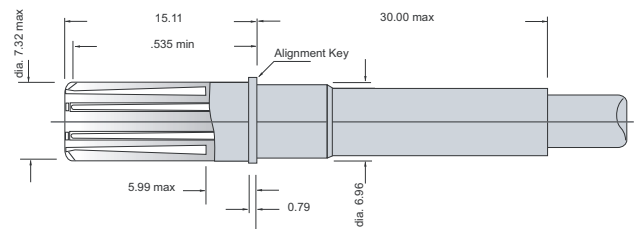

Size 8 Quadrax Pin PCB Mount

Part number	Cable
HCT-442	N/A

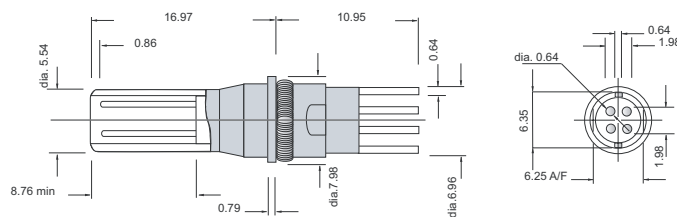

Coax, triax, concentric twinax and quadrax contacts

Size 8 Concentric Twinax Pin (Boeing)

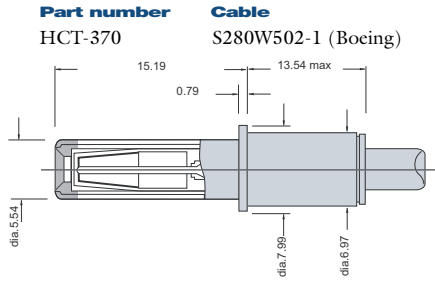

Size 8 Concentric Twinax Socket (Boeing)

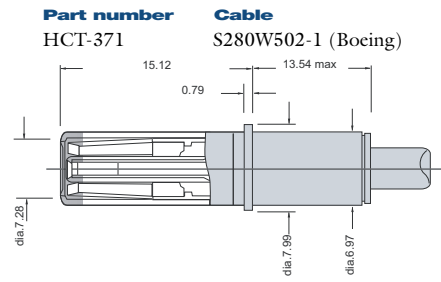

Size 8 Concentric Twinax Pin

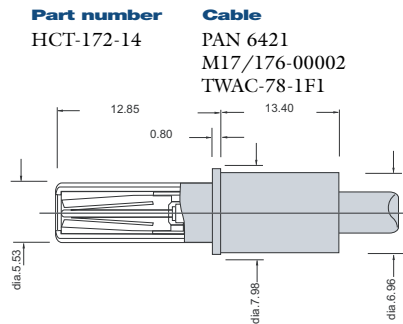

Size 8 Concentric Twinax Socket

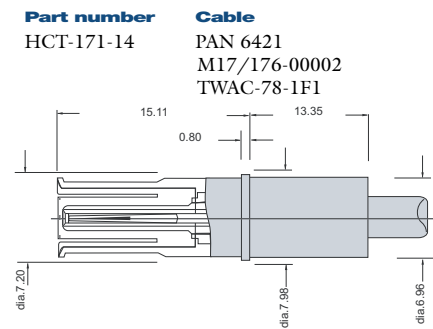

Size 8 Triax Pin

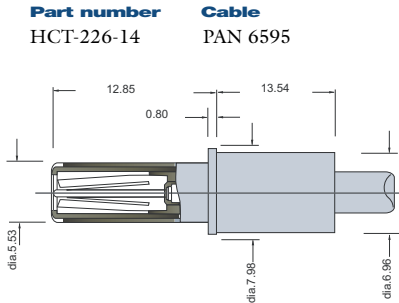

Size 8 Triax Socket

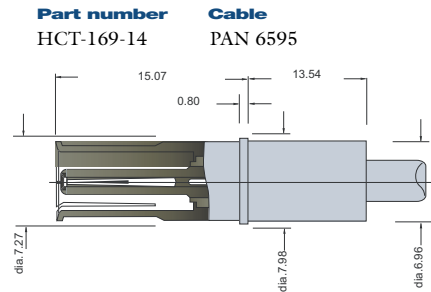

Size 5 Coax Pin

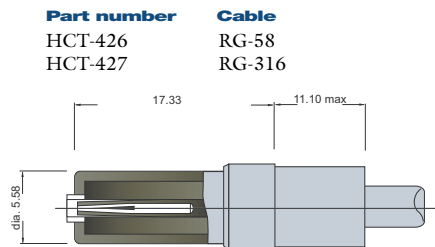

Size 5 Coax Socket

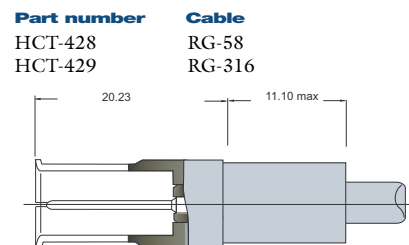

Dimensions are in mm

Coax, triax, concentric twinax and quadrax contacts

Size 5 Concentric Twinax Pin

Part number	Cable
HCT-430	M17/176-00002
HCT-431	RG-403
HCT-432	UT 141-50-50
HCT-433	UT 141-50-22

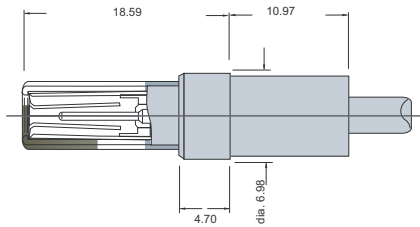

Size 5 Concentric Twinax Socket

Part number	Cable
HCT-434	M17/176-00002
HCT-435	RG-403
HCT-436	UT 141-50-50
HCT-437	UT 141-50-22

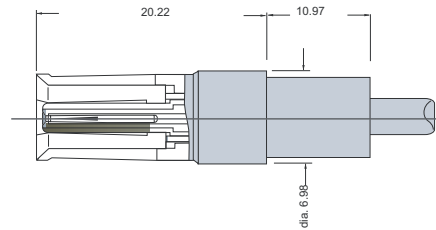

Size 1 Concentric Twinax Pin

Part number	Cable
HCT-438	M17/176-00002
HCT-439	RG-403

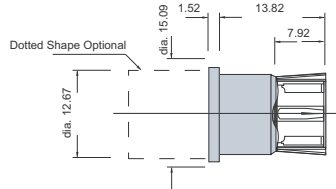

Size 1 Concentric Twinax Socket

Part number	Cable
HCT-440	M17/176-00002
HCT-441	RG-403

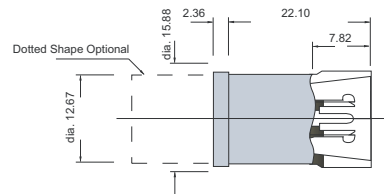

Shell size 1 mechanical details

Shell Size 1 – Plug

Dimensions

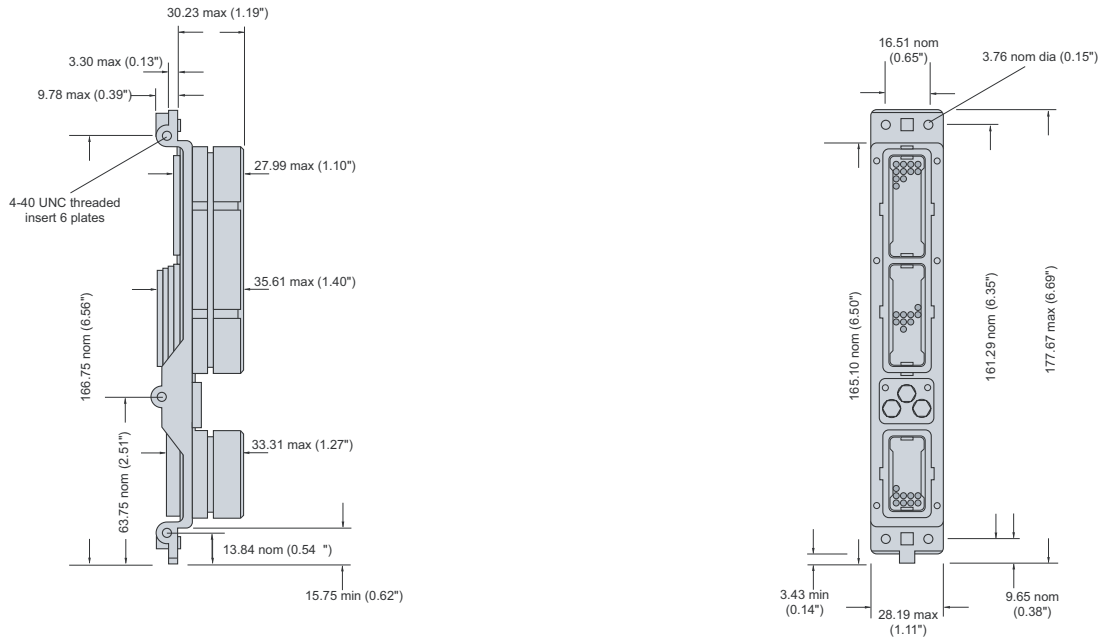

Shell Size 1 – Receptacle

Dimensions

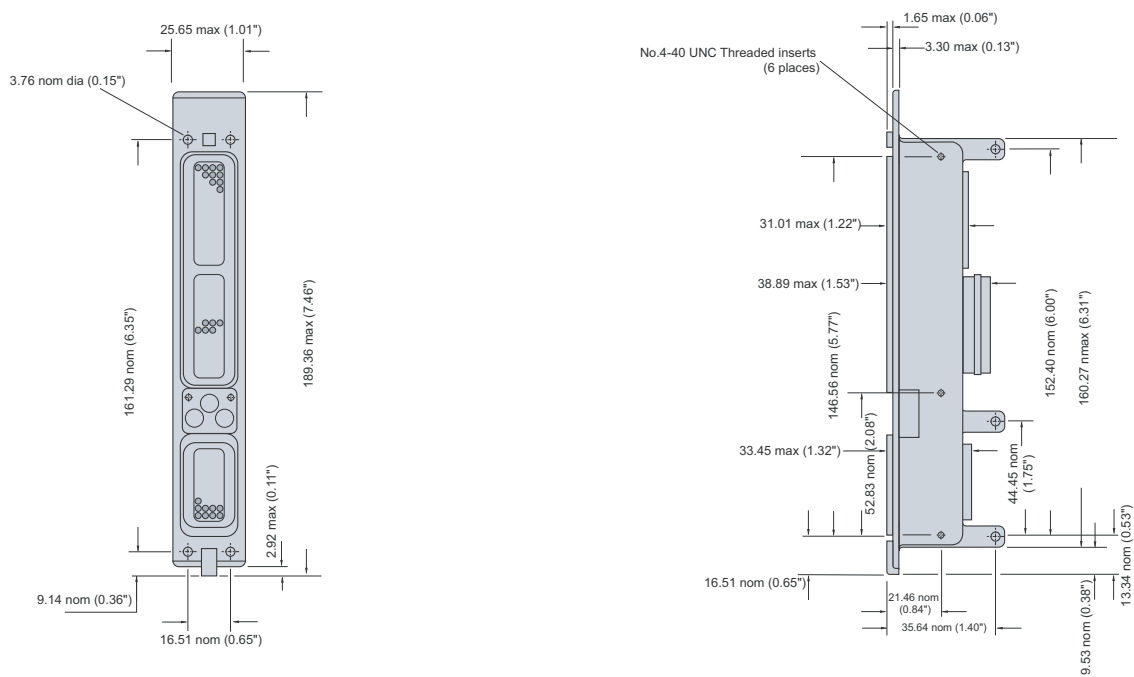

Dimensions are in mm

Shell size 2 mechanical details

Shell Size 2 – Plug

Dimensions

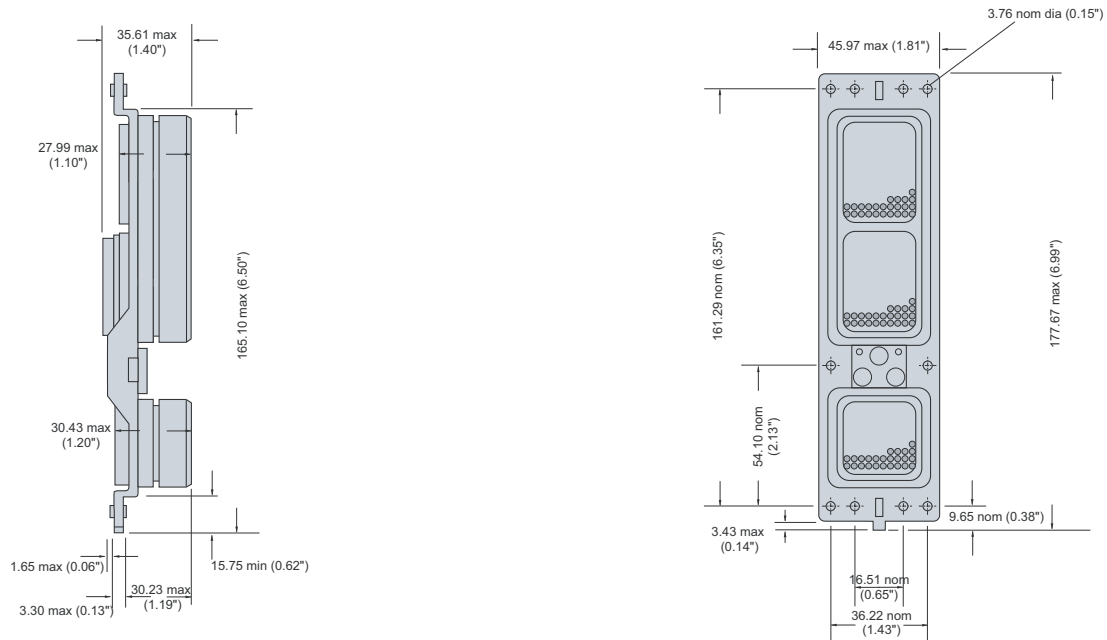

Shell Size 2 – Receptacle

Dimensions

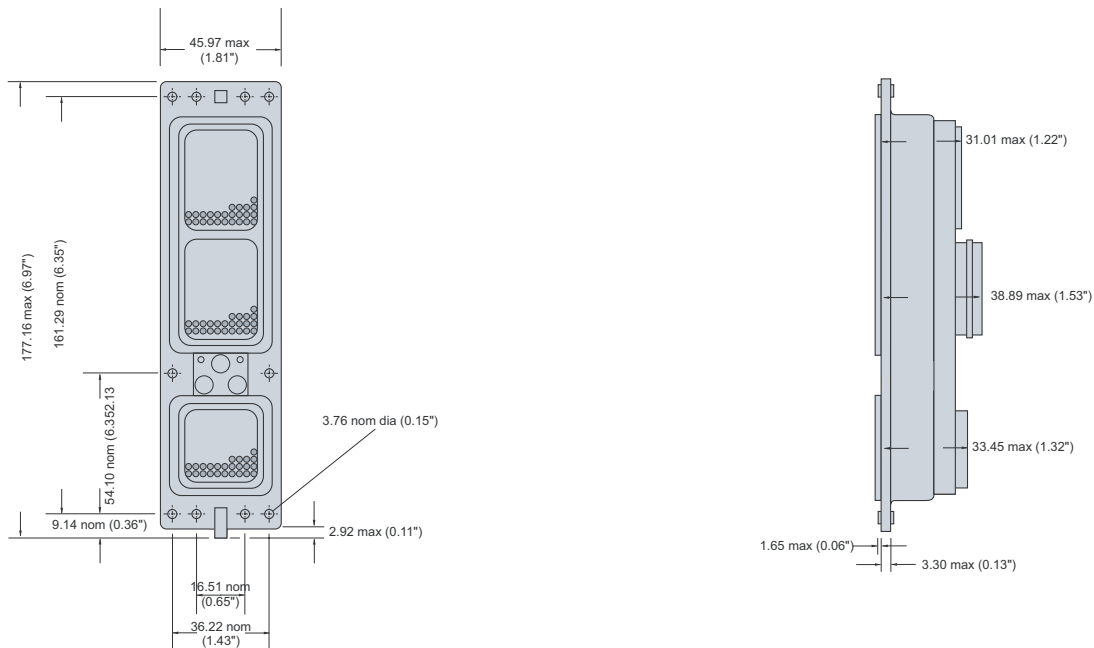

Dimensions are in mm

Shell size 3 mechanical details

Shell Size 3 – Plug

Dimensions

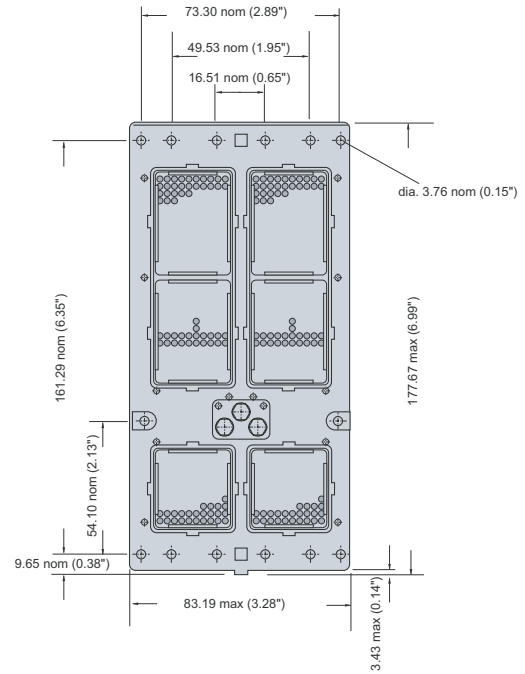
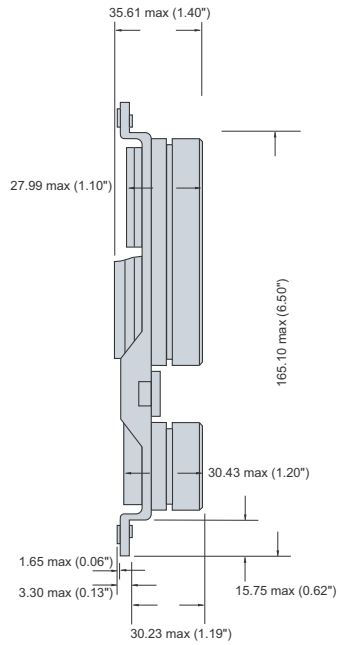

Shell Size 3 – Receptacle

Dimensions

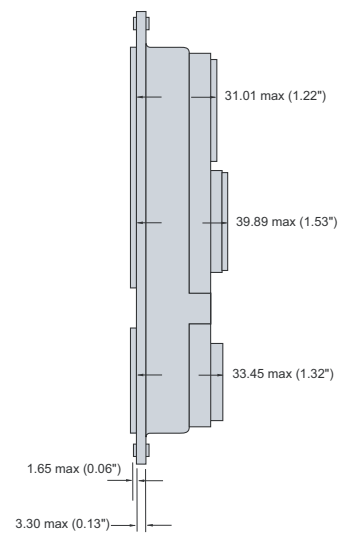
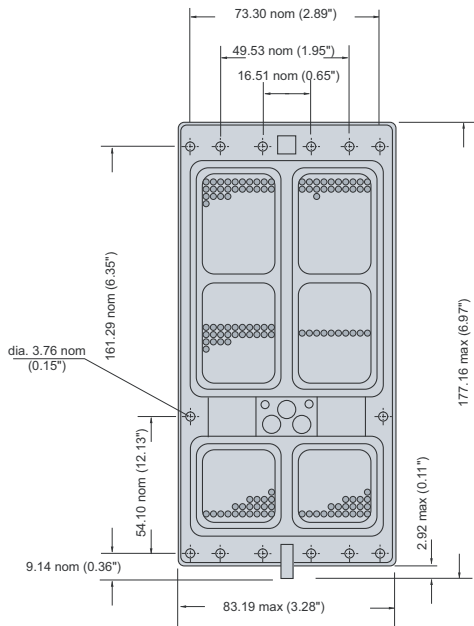

Dimensions are in mm