

SNAPTAC CONNECTOR SERIES

Circular and Rectangular Miniature Snap Fit Connectors



HYPERSPRING® TECHNOLOGY

Snaptac® product range is equipped with Hyperspring® contacts combining our high-reliability hyperboloid contact technology, with the mechanical features of a spring-loaded contact, to produce interconnections with improved signal integrity, high reliability and current density, and proven parametric stability over time.

A key innovation within the Snaptac® connector range is in the design of the spring loaded contact. For the first time, a hyperboloid socket has been combined with a spring loaded plunger to provide a compressible contact.

This arrangement enables the characteristics of very low and stable contact resistance, high current carrying capability, and extremely low wear mechanisms for extended operation over time to be realised within a sealed while unmated connector system. This unique combination enables the spring loading characteristic to be determined separately from the electrical characteristics thus optimising the mechanical, electrical and environmental performance.



TECHNICAL CHARACTERISTICS

Contact Dia	0.50 mm
Current Rating	3 A
Spring Force (max)	1.5 N
Contact Resistance	<15mΩ
Mating Cycles	100,000
Material	
- Non functional parts	Brass plated with Au or Ni
- Spring contact element	CuBe plated with 1.27 µm Au
- Spring element	Stainless steel AISI 302 passivated
- Interface pin connection	Bronze or CuBe plated with 1.27 µm Au
- Contact terminations	Brass or Bronze plated with 1.27 µm Au

TABLE OF CONTENTS

SNAPTAC SERIES

▶ SnapTac Miniature Connectors	2
▶ Applicable documents.....	3
▶ Circular Connector Technical Characteristics	4
Ordering Information	6
Available polarizations	7
Pin Arrangement - View Mating Side	8
Plug - Solder Cup Termination	9
Plug - Solder Cup Termination with Overmoulding and Cabling	9
Plug - Solder Cup Termination with 90° Overmoulding and Cabling.....	9
Receptacle - Straight Through Termination	10
Receptacle - Solder Cup Termination	10
Panel Cut-out	10
Extender - Solder Cup Termination	11
Extender with Overmoulding and Cabling.....	11
Receptacle - Front Panel Mounting with Solder Cup Termination.....	12
Panel Cut-out	12
Other Available options	13
Accessories - Dust Cap.....	16
Cable Preparation	18
▶ Rectangular Connector Technical Characteristics.....	19
Ordering Information	21
Plug - Solder Cup Termination	22
Plug with Overmoulding and Cabling.....	22
Receptacle - Solder Cup Termination	23
Receptacle - Straight Through Termination.....	23
Panel Cut-out	23
Available polarizations for 12 and 21 ways	24
Accessories - Dust Cap.....	25
30 Ways Plug - Solder Cup Termination	26
30 Ways Plug with Overmoulding and Cabling	26
30 Ways Receptacle - Solder Cup Termination	27
30 Ways Receptacle - Straight Through Termination.....	27
30 Ways Plug - Front Panel Mount	28

SNAPTAC MINIATURE CONNECTORS

Snaptac® connectors provide a very reliable and robust connector system ideal for use in potentially dirty environments or where fast and easy mating and demating characteristics are required. Through the use of compressible contacts, potential mating and connectivity problems that can arise when the bores of conventional socket contacts become contaminated by the mud and detritus that may occur in everyday use are avoided. The easy to clean nature of the target and chisel blade contact mechanism, together with the sealed when unmated characteristic of both plug and receptacle, make this connector system ideal for harsh environments where reliability is paramount.

Available geometries

Snaptac® connectors are available in both circular (7-, 13-, and 19-) and rectangular (12-, 21-, and 30-) way geometries.

The SnapTac connector plugs are available in two versions, with and without over-moulding, following requests for both turn-key solutions and easy integration into existing designs.

A 90° overmoulded version is also available for the circular connector. The receptacle offers straight through and solder cup termination styles.

The locking mechanism is easy and fast: the circular connector range features a snap on locking, the 12 and 21 way rectangular connectors are push pull, the 30 way rectangular connector has a quick turn locking device.

7, 13 and 19 way circular extenders, with and without overmoulding, are available for applications requiring in-line connection.

Several hardware coding are available to avoid mismatching and to satisfy the customer technical needs as many non standard options are available. Please contact our sales office if you don't find in the catalogue the version that meets your requirements.

Up to 10,000 mating cycles

Tactical communication equipment must survive the rigours of hostile environments and withstand the damage of dust, sand, mud. The connectors used on both the handset and headset can be mated and unmated thousand of times during the equipment life. Snaptac® connectors ensure higher durability and superior performance through the use of the unique Hypertac hyperboloid

contact technology, offering shock and vibration immunity, low contact resistance, high current and voltage ratings, low mating forces, long life and low rate of wear.

The HyperSpring® spring loaded contacts used inside the connectors cannot be damaged or bent from mishandling. Their inherent self cleaning wiping action removes surface contamination, thus ensuring that the connector can't be damaged by the building up of surface films.

Lighter and Compact

Snaptac® connectors combine robust environmental performance with compact size and light weight, which make them ideal for lightweight, compact, wearable EMI shielded electronic systems for applications including communication, identification / recognition, and other critical tasks.

Waterproof and EMI protected

Snaptac® connectors are IP67 sealed according to IEC529 when mated and unmated. They incorporate full line EMI shielding and provide for high robustness throughout their lifetime.

Accessories - Dust caps

Dust caps are available to protect the connector when unmated and to ensure full EMI shielding. The metal version is supplied in the same material of the connector (aluminium, stainless steel), the rubber version is available in fluoro-polymer rubber.

Special flanges have been designed to facilitate the rectangular connector rear panel mounting.

Value Added services

Technical performance data hereby reported refer to Snaptac® connectors equipped with Hypertac cabling and overmoulding. Custom and value added solutions are provided for customers' specific requirements including cabling, mechanical, instrumentation housing and testing. Custom solutions save valuable engineering and manufacturing time for customers and ensure the overall performance of the final product.

▶ APPLICABLE DOCUMENTS

Base Material - Standard Specification	
MIL-M-24519	Moulding Plastics, Electrical, Thermoplastic
ASTM-B-16	Free-Cutting Brass Rod, Bar and Shapes for Use in Screw Machines
ASTM-B-121	Leaded Brass Plate, Sheet, Strip, and Rolled Bar
ASTM-B-139	Standard Specification for Phosphor Bronze Rod, Bar, and Shapes
ASTM-B-196	Copper-Beryllium Alloy Rod and Bar
ASTM-B-197	Copper Beryllium Alloy Wire
ASTM-B-209	Aluminum and Aluminum-Alloy Sheet and Plate
ASTM-B-455	Standard Specification for Copper-Zinc-Lead Alloy (Leaded-Brass) Extruded Shapes
ASTM-A-582	Free-Machining Stainless Steel Bars and Heat Resisting Steel Bars, Hot Rolled or Cold Finished
Surface Treatment - Standard Specification	
MIL-C-26074	Coatings, Electroless Nickel
MIL-STD-869	Standard Specification for Flame Spraying
ASTM-B-488	Electrodeposited Coatings of Gold for Engineering Uses
ASTM-A-967	Chemical Passivation Treatments for Stainless Steel Parts
QQ-N-290	Nickel Plating Electrodeposited
Test Procedures	
EIA 364	Test Methods For Electrical Connectors
UL94	Test Methods For Flammability Rating
IEC 529	Degrees of protection provided by enclosures
IEC 512	Electromechanical components for electronic equipment

TECHNICAL CHARACTERISTICS

CIRCULAR CONNECTOR

General	
Hyperspring® Contact Number	7,13,19
Receptacle Contact Termination	Solder Cup, Straight PCB
Plug Contact Termination	Solder Cup, Straight PCB
AWG Contact	28-24
Cable Diameter Range	Max 6 mm (7 ways) - Max 7.5 mm (13 ways) - Max 8.5 mm (19 ways)
Materials and Plating	
Inner Insulators	Polyphenilensulfide (PPS) type GST-40F per MIL-M-24519 V0 per UL 94
Interface Insulators	NBR Rubber per CEI 2019 Black V0 per UL 94
Overmoulded	Hot melt Polyamide 6.6
Housing	(see table 1)
Locking Hardware	Canted coil spring: Beryllium Copper
EMI-Gasket	Canted coil spring: Beryllium Copper
Hyperspring® Contacts	
Non Functional Parts	Brass as per ASTM-B-455 plated with Au as per ASTM-B-488
Spring Contact Element	CuBe as per ASTM-B-197 plated with Au as per ASTM-B-488
Spring Element	Stainless Steel AISI 302 passivated as per ASTM-A-967
Interface pin connection	Bronze as per ASTM-B-139 plated with Au as per ASTM-B-488
Plug contact terminations (<i>solder cups</i>)	Brass as per ASTM-B-455 plated Au as per ASTM-B-488
Bonding Agent	Epoxy resin
Mass data	Related to standard connectors configuration (see table 2)
Electrical Characteristics	
EMI Shielding	360° shield coverage
Current Rating	3A@25°C for each contact according to IEC 512-3
Dielectric Withstanding Voltage (<i>between contacts</i>)	500 Vrms at sea level and 150 Vrms at 21336m according to EIA 364.20
Contact Resistance (<i>low level</i>)	< 15 mΩ for each contact according to EIA 364.6
Insulation Resistance	5000 MΩ @ 500V d.c. according to EIA364.21
Electrical Bonding Resistance	(see table 3)
Mechanical and Environmental Characteristics	
Temperature Range	-55°C +85°C
Temperature cycling	EIA364.32 Method A
Salt Spray	EIA364.26 Condition A - mated connectors
Humidity	EIA364.31 Method IV
IP Level	67 mated and unmated IEC 529
Vibration	EIA364.28 Condition III
Shock	EIA364.27 Condition G
Hyperspring® force (<i>single contact</i>)	Max 1.5 [N]
Connector Mating / Unmating Force	EIA364.09 (see table 4)

Table 1

Material		Surface treatment			
		Z	N	P	W
Aluminium Alloy AV2024 ASTM-B-209	AA*	Zn/Co on Chemical Black 5 µm SAE AMS-C-26074	Chemical Ni Matt Grey 20mm SAE AMS-C-26074		
	BR*				
Brass CuZn39Pb3 ASTM-B-16					Metal Spraying Tungsten Carbide Black 1-5mm as per MIL-STD-869
Stainless Steel AISI316 ASTM-B-582	XS*			Passivation Matt Grey as per ASTM-A-967	

Table 2

		Mass data		
		(grams)	Plug	Receptacle
C07	AA	4	4.8	4.2
	BR/XS	7.6	10.2	8
C13	AA	6.7	6.5	6
	BR/XS	11.4	13.5	12
C19	AA	8.4	7.1	7
	BR/XS	13.7	15.1	14.2

AA: Aluminium Alloy; BR: Brass; XS: Stainless Steel

Table 3

Electrical Bonding Resistance Vs Material/Surface Treatment				
AAN	AAZ	BRN/BRW	XSP	XSW
<15 mΩ	<800 mΩ	<40 mΩ	<250 mΩ	<40 mΩ

Table 4

		Mating & unmating force				Life [# Cycle]
		Mating [N]		Unmating [N]		
		Min	Max	Min	Max	
C07	AA*/BRN/XSP	20	40	18	45	1K Cycles
	BRW/XSW					10K Cycles
C13	AA*/BRN/XSP	20	40	18	45	1K Cycles
	BRW/XSW					10K Cycles
C19	AA*/BRN/XSP	25	45	20	50	1K Cycles
	BRW/XSW					10K Cycles

AA: Aluminium Alloy; BR: Brass; XS: Stainless Steel

HOW TO ORDER

ST1091

SNAPTAC

1

2

3

4

5

6

7

8

1 ▶ CONNECTOR FAMILY**2** ▶ CONNECTOR TYPE**C** CIRCULAR**3** ▶ NUMBER OF WAYS**07** **13** **19****4** ▶ CONNECTOR STYLE**P** PLUG **R** RECEPTACLE REAR PANEL MOUNT **E** EXTENDER IN LINE **W** EXTENDER REAR PANEL MOUNT
X RECEPTACLE FRONT PANEL MOUNT **Y** PLUG FRONT PANEL MOUNT **Z** PLUG REAR PANEL MOUNT**5** ▶ TERMINATION STYLE**S** SOLDER CUP **D** PCB STRAIGHT**6** ▶ HOUSING POLARIZATIONS

FROM C00 UP TO C07

7 ▶ WIRING DIAGRAM ⁽¹⁾

FROM CH01 UP TO CHnn

8 ▶ BASE MATERIAL & SURFACE PROTECTION**AAZ** ALUMINIUM ALLOY (AV2024) - ZINC COBALT **AAN** ALUMINIUM ALLOY (AV2024) - NICHEL
BRN BRASS - NICKEL **BRW** BRASS - BLACK TUNGSTEN CARBIDE **XSP** STAINLESS STEEL AISI 316 - PASSIVATED
XSW STAINLESS STEEL AISI 316 - BLACK TUNGSTEN CARBIDE*(1) Omit in case of connector without cable harnessing***NOTES**

1. Connectors identification does not require empty space (eg: C13PSC01AAZ)
2. Harnessing identification does not require empty space (eg: C13PSC01CH01AAZ)
3. Harnessing is applicable only to connectors type P, E, W.

▶ AVAILABLE POLARIZATIONS

RECEPTACLE MATING SIDE VIEW

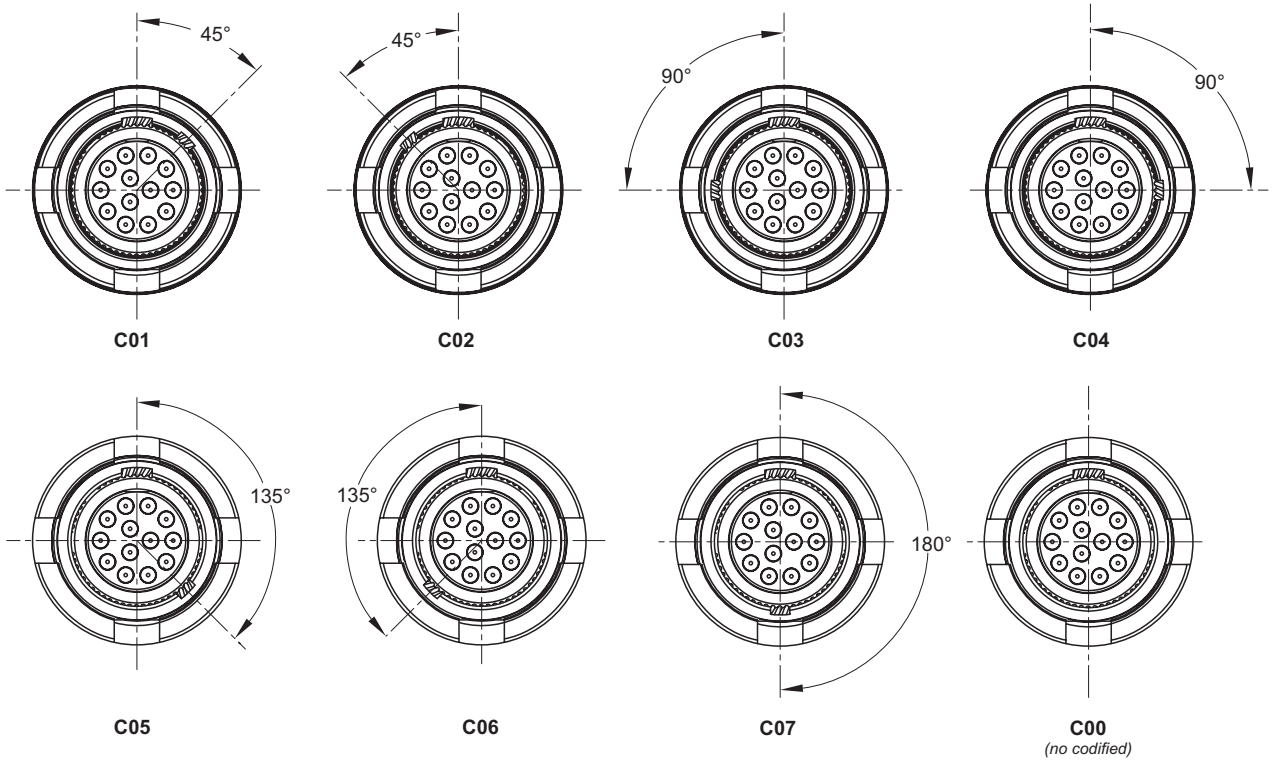

PLUG MATING SIDE VIEW

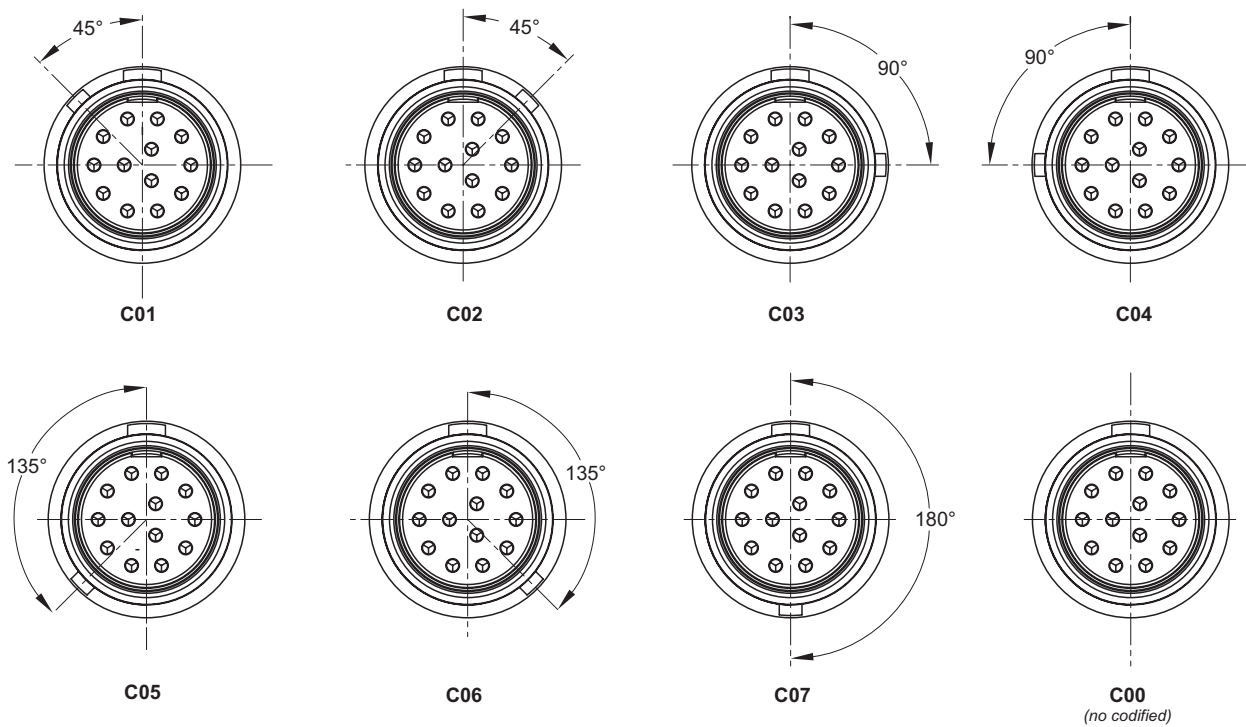

▶ CONTACT ARRANGEMENT - VIEW MATING SIDE

RECEPTACLE C07R

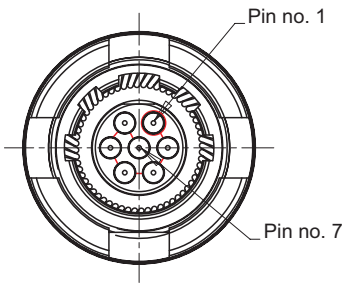

RECEPTACLE C13R

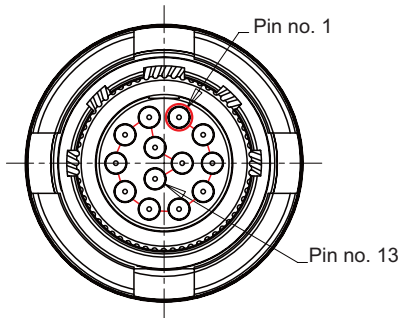

RECEPTACLE C19R

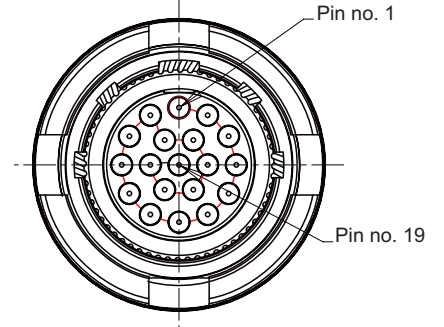

PLUG C07P

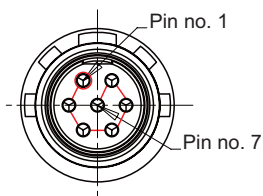

PLUG C13P

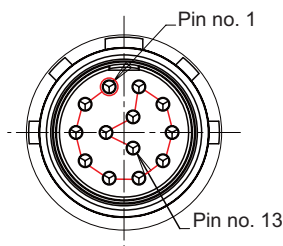

PLUG C19P

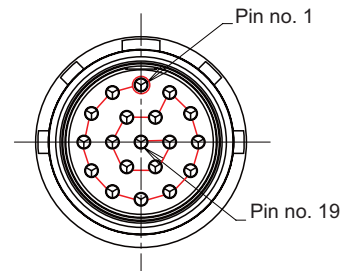

► PLUG

PLUG - SOLDER CUP TERMINATION

No. of ways	PN	A	B
7	C07PSC-----	Ø 8.30	Ø 10.20
13	C13PSC-----	Ø 11.30	Ø 13.00
19	C19PSC-----	Ø 12.30	Ø 14.00

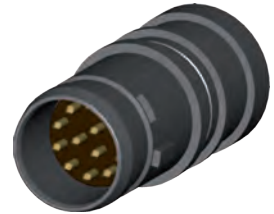
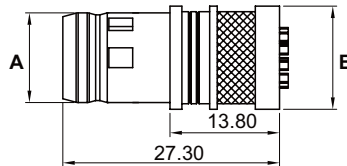
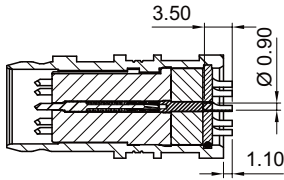

PLUG - SOLDER CUP TERMINATION WITH OVERMOULDING AND CABLING

No. of ways	PN	A	B	C	D
7	C07PSC--CH-----	Ø 14.50	Ø 9.50	Ø 6.00 max	Ø 8.30
13	C13PSC--CH-----	Ø 17.20	Ø 11.00	Ø 7.50 max	Ø 11.30
19	C19PSC--CH-----	Ø 18.20	Ø 12.00	Ø 8.50 max	Ø 12.30

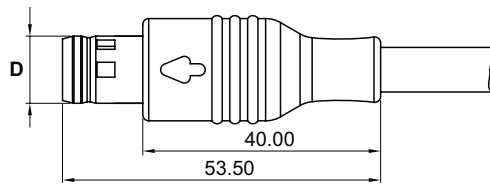
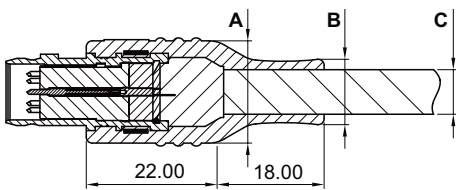

PLUG - SOLDER CUP TERMINATION WITH 90° OVERMOULDING AND CABLING

No. of ways	PN	A	B	C	D	E
7	C07PSC--CH-----	Ø 8.30	Ø 14.50	28.50	Ø 9.50	Ø 6.00 max
13	C13PSC--CH-----	Ø 11.30	Ø 17.20	31.20	Ø 11.00	Ø 7.50 max
19	C19PSC--CH-----	Ø 12.30	Ø 18.20	32.20	Ø 12.00	Ø 8.50 max

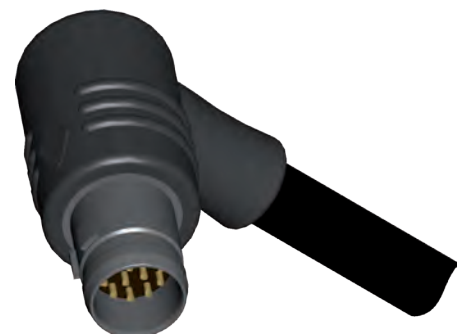
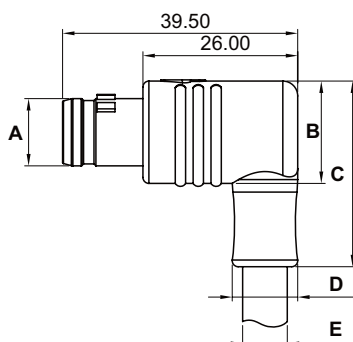

▶ RECEPTACLE

RECEPTACLE - STRAIGHT THROUGH TERMINATION



No. of ways	PN	A	B	C	D
7	C07RDC----	Ø 11.00	Ø 15.40	M12x0.75	10.00
13	C13RDC----	Ø 13.80	Ø 18.40	M15x0.75	13.00
19	C19RDC----	Ø 14.80	Ø 19.40	M16x0.75	14.00

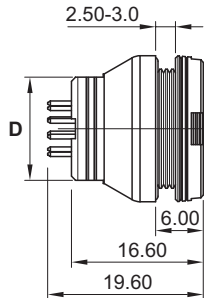
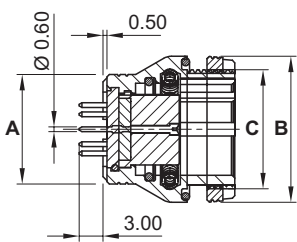

MOUNTING PATTERN - COMPONENT SIDE

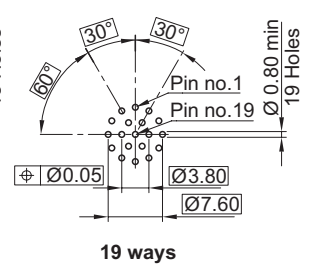
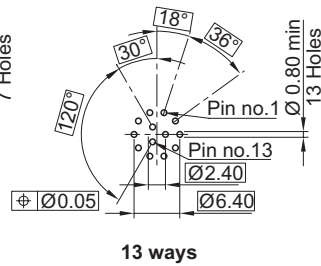
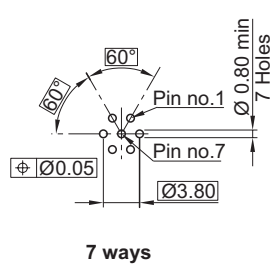

RECEPTACLE - SOLDER CUP TERMINATION

No. of ways	PN	A	B	C	D
7	C07RSC----	Ø 11.00	Ø 15.40	M12x0.75	10.00
13	C13RSC----	Ø 13.80	Ø 18.40	M15x0.75	13.00
19	C19RSC----	Ø 14.80	Ø 19.40	M16x0.75	14.00

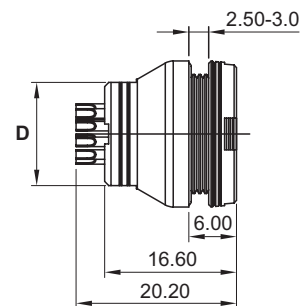
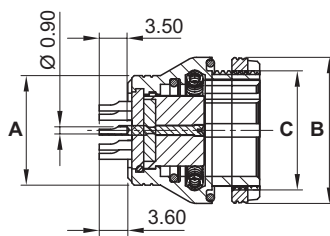

▶ PANEL CUT-OUT

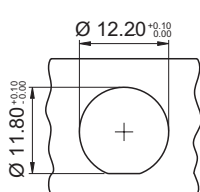

7 ways

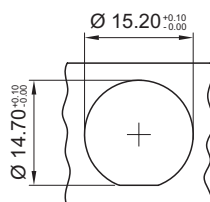

13 ways

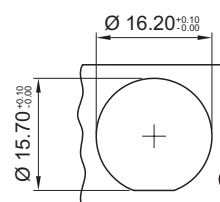

19 ways

Note: panel thickness max 3 mm

EXTENDER

EXTENDER - SOLDER CUP TERMINATION

No. of ways	PN	A	B
7	C07ESC----	Ø 10.20	Ø 13.00
13	C13ESC----	Ø 13.00	Ø 16.00
19	C19ESC----	Ø 14.00	Ø 17.00

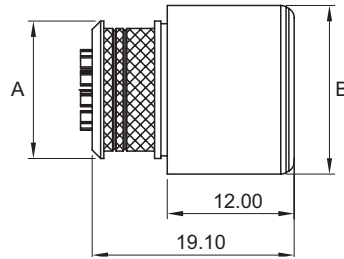
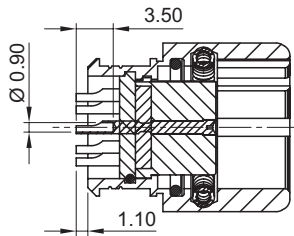

EXTENDER WITH OVERMOULDING AND CABLING

No. of ways	PN	A	B	C	D
7	C07ESC--CH----	Ø 6.00 max	Ø 9.50	Ø 14.50	Ø 13.00
13	C13ESC--CH----	Ø 7.50 max	Ø 11.00	Ø 17.20	Ø 16.00
19	C19ESC--CH----	Ø 8.50 max	Ø 12.00	Ø 18.20	Ø 17.00

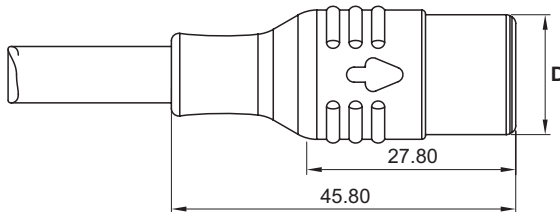
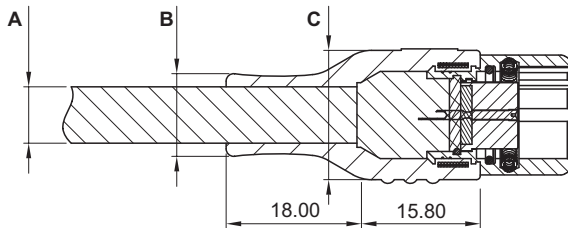

▶ RECEPTACLE - FRONT PANEL MOUNTING WITH SOLDER CUP TERMINATION

No. of ways	PN	A	B	C	D
7	C07XSC----	M12x0.75	Ø 15.40	Ø 12.00	14.00
13	C13XSC----	M15x0.75	Ø 18.40	Ø 15.00	17.00
19	C19XSC----	M16x0.75	Ø 19.40	Ø 16.00	18.00

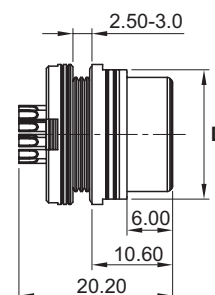
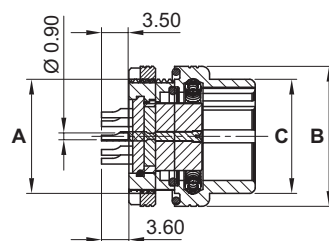

▶ PANEL CUT-OUT

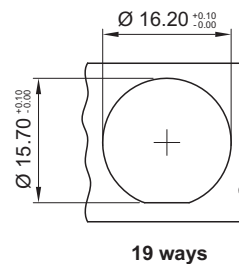
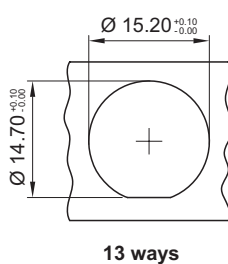
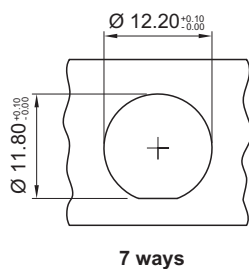

Note: panel thickness max 3 mm

▶ OTHER AVAILABLE OPTIONS

7 WAYS PLUG - FRONT PANEL MOUNTING WITH SOLDER CUP TERMINATION

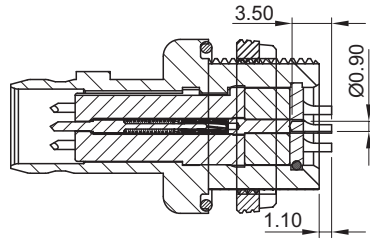

Ref. C07YSC-----

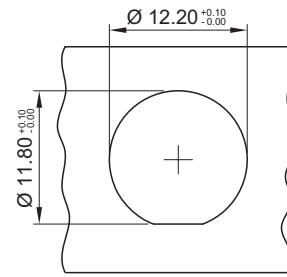
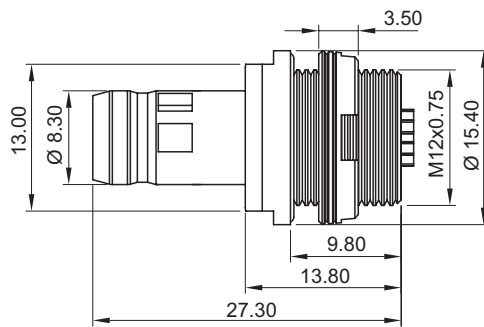

Panel cut-out

Note: for 13 and 19 ways connector details please contact our sales office.

13 WAYS PLUG - REAR PANEL MOUNTING WITH SOLDER CUP TERMINATION

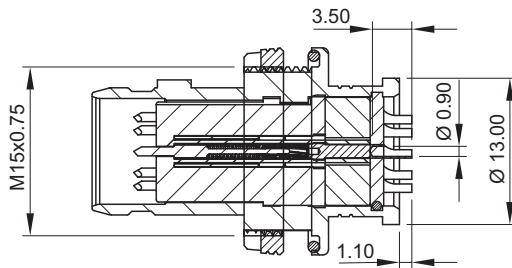

Ref. C13ZSC-----

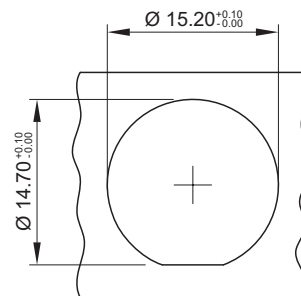
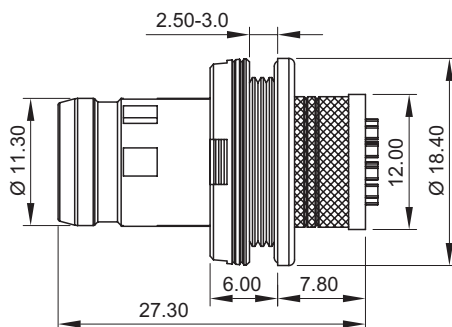

Panel cut-out
panel thickness max 3 mm

Note: for 7 and 19 ways connector details please contact our sales office.

▶ OTHER AVAILABLE OPTIONS

13 WAYS PLUG - REAR PANEL MOUNTING WITH OVERMOULDING AND CABLING

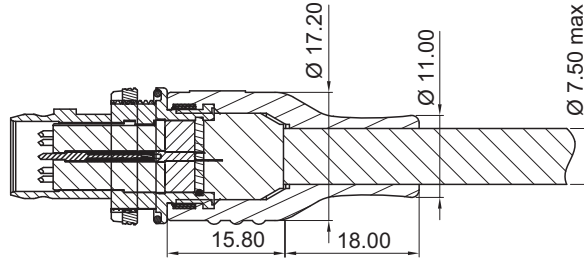

Ref. C13ZSC--CH----

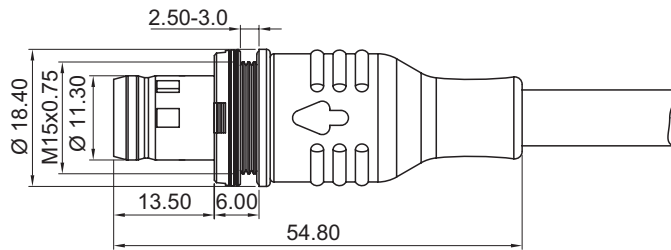
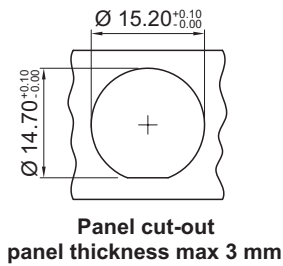

Note: for 7 and 19 ways connector details please contact our sales office.

19 WAYS EXTENDER - REAR PANEL MOUNTING WITH SOLDER CUP TERMINATION

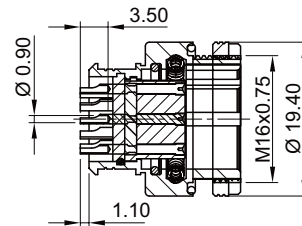

Ref. C19WSC-----

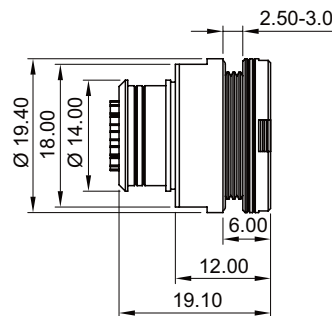
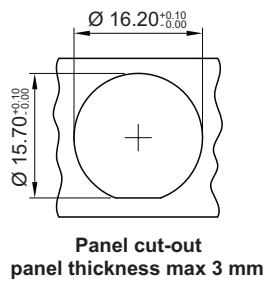

Note: for 7 and 13 ways connector details please contact our sales office.

OTHER AVAILABLE OPTIONS

19 WAYS EXTENDER - REAR PANEL MOUNTING WITH OVERMOULDING AND CABLING

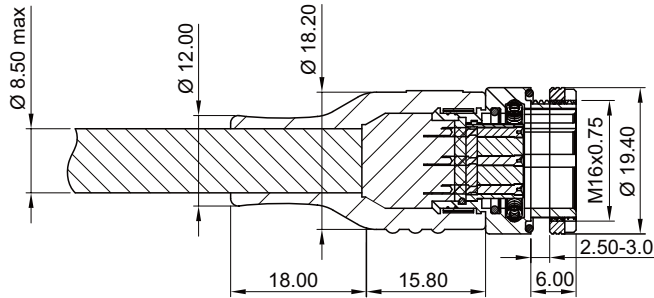

Ref. C19WSC--CH-----

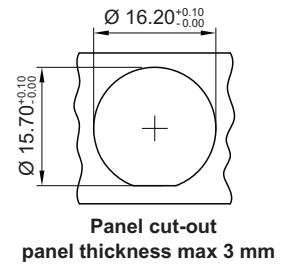
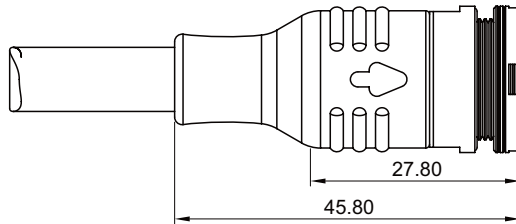

Note: for 7 and 13 ways connector details please contact our sales office.

HOW TO ORDER

ACCESSORIES - DUST CAP



1 ▶ CONNECTOR FAMILY

2 ▶ CONNECTOR TYPE

C CIRCULAR

3 ▶ NUMBER OF WAYS

07 **13** **19**

4 ▶ DUST CAP TYPE

CP DUST CAP FOR PLUG **CR** DUST CAP FOR RECEPTACLE

5 ▶ DUST CAP VERSION

MET METALLIC CAP **RUB** RUBBER CAP

6 ▶ BASE MATERIAL & SURFACE PROTECTION

AAZ* ALUMINIUM ALLOY (AV2024) - ZINC COBALT **AAN*** ALUMINIUM ALLOY (AV2024) - NICHEL
BRN* BRASS - NICKEL **BRW*** BRASS - BLACK TUNGSTEN CARBIDE **XSP*** STAINLESS STEEL AISI 316 - PASSIVATED
XSW* STAINLESS STEEL AISI 316 - BLACK TUNGSTEN CARBIDE **FPR**** FLUORO POLYMER RUBBER

* Only for MET
 ** Only for RUB

► DUST CAP

METAL VERSION FOR RECEPTACLE

No. of ways	PN	A
7	C07CRMET---	Ø 15.00
13	C13CRMET---	Ø 17.50
19	C19CRMET---	Ø 18.50

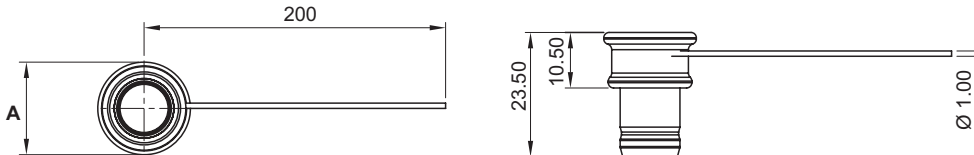

METAL VERSION FOR PLUG

No. of ways	PN	A
7	C07CPMET---	Ø 15.00
13	C13CPMET---	Ø 17.50
19	C19CPMET---	Ø 18.50

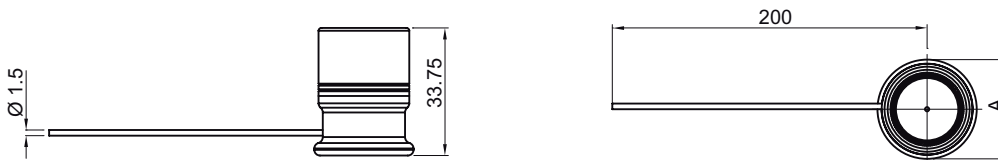

RUBBER VERSION FOR RECEPTACLE

No. of ways	PN	A	B	C
7	C07CRRUBFPR	23.00	Ø 9.00	Ø 13.00
13	C13CRRUBFPR	26.00	Ø 12.00	Ø 16.00
19	C19CRRUBFPR	27.00	Ø 13.00	Ø 17.00

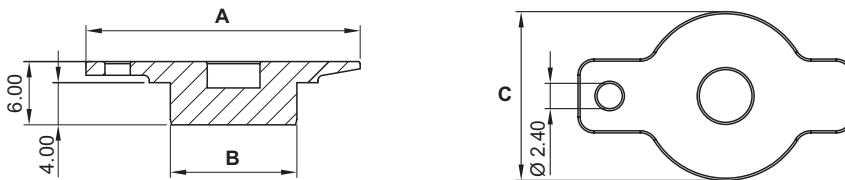

RUBBER VERSION FOR PLUG

No. of ways	PN	A	B	C
7	C07CPRUBFPR	11.70	13.00	20.50
13	C13CPRUBFPR	14.70	16.50	22.25
19	C19CPRUBFPR	15.70	17.00	22.50

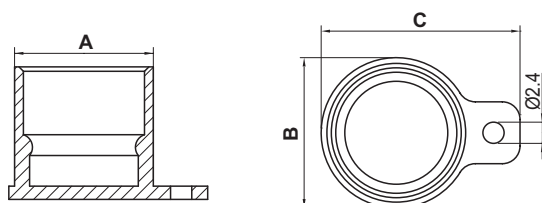

▶ **CABLE PREPARATION**

See below the stripping lengths for braid shield (A) and single wire (B & C).

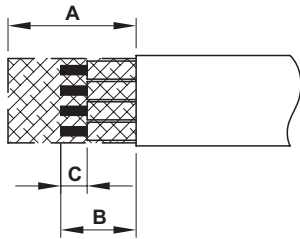

	Plug (ref P)	Extender (ref E)
A	15	13
B	10	10
C	3.5	3.5

EMI/EMC PROTECTION

Plug (ref. P), extender in line (ref. E) and extender rear panel mounting (ref. W) of this specification are designed to be supplied with assembled cables. The electrical continuity between metal shell and cable shield is granted by a specific metallic coil spring for cable braid as showed in the picture.

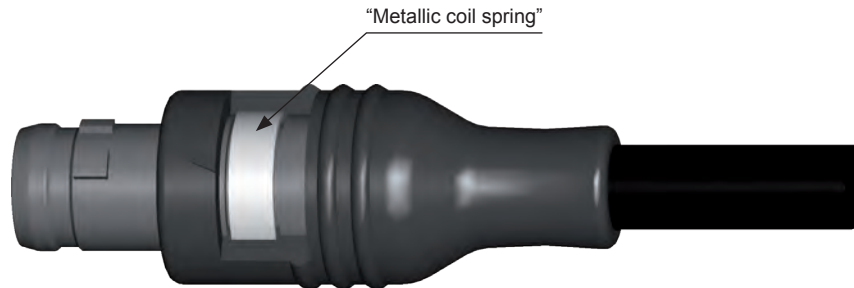

Connector Size	Order Reference
C07	M1035
C13	M1036
C19	M1036

See below the knurled area for braid shield connection.

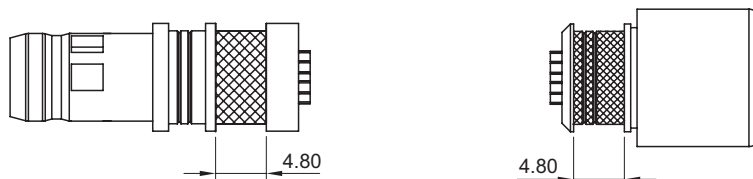

TECHNICAL CHARACTERISTICS

RECTANGULAR CONNECTOR

General	
Hyperspring® Contact Number	12, 21, 30
Receptacle Contact Termination	Solder Cup, Straight PCB
Plug Contact Termination	Solder Cup
AWG Contact	30-24
Cable Diameter Range	Max 8 mm
Materials and Plating	
Inner Insulators	Polyphenilensulfide (PPS) type GST-40F per MIL-M-24519 V0 per UL 94
Interface Insulators	NBR Rubber per CEI 2019 Black V0 per UL 94
Overmoulded	Hot melt Polyamide 6.6
Housing	<i>(see table 1)</i>
Locking Hardware	Stainless Steel AISI 3xx – Passivated as per ASTM-A-967 – Coating Oxide Black as per MIL-DTL-13924D – Metal Spraying Tungsten Carbide Black as per MIL-STD-869
EMI-Gasket	Conductive Silicon
Hyperspring® Contacts	
Non Functional Parts	Brass as per ASTM-B-455 plated with Au as per ASTM-B-488
Spring Contact Element	CuBe as per ASTM-B-197 plated with Au as per ASTM-B-488
Spring Element	Stainless Steel AISI 302 passivated as per ASTM-A-967
Interface pin connection	Bronze as per ASTM-B-139 plated with Au as per ASTM-B-488
Plug contact terminations (<i>solder cups</i>)	Brass as per ASTM-B-455 plated Au as per ASTM-B-488
Bonding Agent	Epoxy resin
Mass data	Related to standard connectors configuration <i>(see table 2)</i>
Electrical Characteristics	
EMI Shielding	360° shield coverage
Current Rating	3A@25°C for each contact according to IEC 512-3
Dielectric Withstanding Voltage (<i>between contacts</i>)	500 Vrms at sea level and 150 Vrms at 21336m according to EIA 364.20
Contact Resistance (<i>low level</i>)	< 15 mΩ for each contact according to EIA 364.6
Insulation Resistance	5000 MΩ @ 500V d.c. according to EIA364.21
Mechanical and Environmental Characteristics	
Temperature Range	-55°C +85°C
Temperature cycling	EIA364.32 Method A
Salt Spray	EIA364.26 Condition A - mated connectors
Humidity	EIA364.31 Method IV
IP Level	67 mated and unmated IEC 529
Vibration	EIA364.28 Condition III
Shock	EIA364.27 Condition G
Hyperspring® force (<i>single contact</i>)	Max 1.5 [N]
Connector Mating / Unmating Force	Max 60 [N] (12ways) – Max 70 [N] (21ways) - Max 80 [N] (30ways)

Table 1

Material		Surface treatment	
		Z	N
Aluminium Alloy AV2024 <i>ASTM-B-209</i>	AA*	Zn/Co on Chemical Ni Black 5 µm SAE AMS-C-26074 Class 1	Chemical Ni Matt Grey 20 µm SAE AMS-C-26074 Class 1

Table 2

(grams)	Mass data		
	Plug	Plug (front panel mount)	Receptacle
R12	16	NA	5.5
R21	23	NA	7.5
R30	38	18	7.5

HOW TO ORDER

ST1089

SNAPTAC

1

2

3

4

5

6

7

8

1 ▶ CONNECTOR FAMILY**2** ▶ CONNECTOR TYPE**R** RECTANGULAR**3** ▶ NUMBER OF WAYS**12** **21** **30****4** ▶ CONNECTOR STYLE**P** PLUG **R** RECEPTACLE FRONT PANEL MOUNT **Y** PLUG FRONT PANEL MOUNT (only 30 ways)**5** ▶ TERMINATION STYLE**S** SOLDER CUP **D** PCB STRAIGHT (length = 3.15 mm) **L** PCB STRAIGHT (length = 14 mm)**6** ▶ HOUSING POLARIZATIONS

FROM C00 UP TO C07 (only for 12 & 21 ways) - (preferred polarizations C01 - C06 - C11 - C16)

7 ▶ WIRING DIAGRAM ⁽¹⁾

FROM CH01 UP TO CHnn

8 ▶ BASE MATERIAL & SURFACE PROTECTION**AAZ** ALUMINIUM ALLOY (AV2024) - ZINC COBALT **AAN** ALUMINIUM ALLOY (AV2024) - NICHEL*(1) Omit in case of connector without cable harnessing***NOTES**

1 Connectors identification does not require empty space (eg: R12PSC01AAZ)

2 Harnessing identification does not require empty space (eg: R12PSC01CH01AAZ)

3 Harnessing is applicable only to connectors type P

4 Straight termination contacts are applicable only to R&Y

► PLUG

PLUG - SOLDER CUP TERMINATION

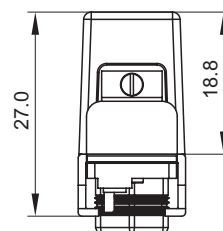
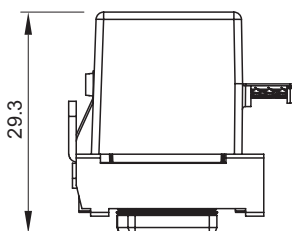
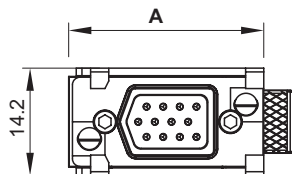

No. of ways	PN	A
12	R12PSC-----	25.8
21	R21PSC-----	32.4

PLUG WITH OVERMOULDING AND CABLING

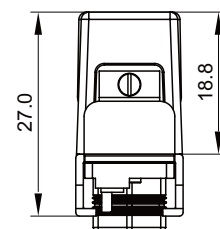
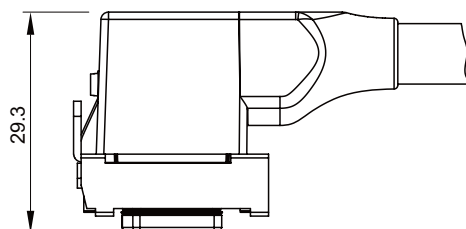
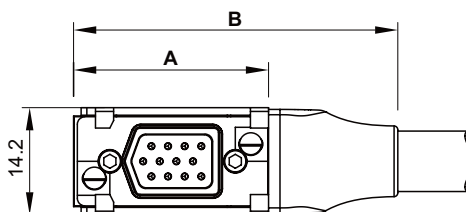

No. of ways	PN	A	B
12	R12PSC--CH-----	25.8	42,9
21	R21PSC--CH-----	32.4	49.6

RECEPTACLE

RECEPTACLE - SOLDER CUP TERMINATION

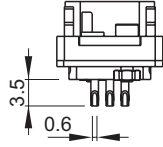
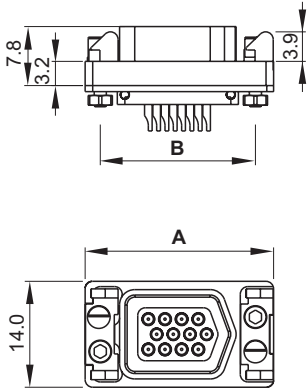

No. of ways	PN	A	B
12	R12RSC----	24.9	20.5
21	R21RSC----	31.5	27.1

RECEPTACLE - STRAIGHT THROUGH TERMINATION

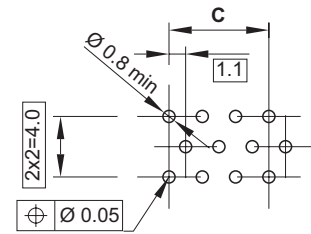
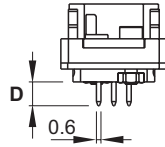
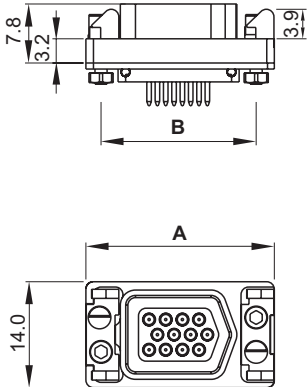

Mounting pattern - Component side



No. of ways	PN	A	B	C	D
12	R12RDC----	24.9	20.5	6.6	3.15
	R12RLC----				14
21	R21RDC----	31.5	27.1	13.2	3.15
	R21RLC----				14

PANEL CUT-OUT

12 Ways

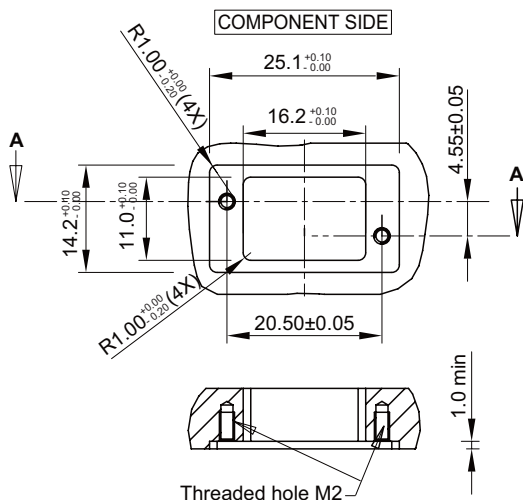

21 Ways

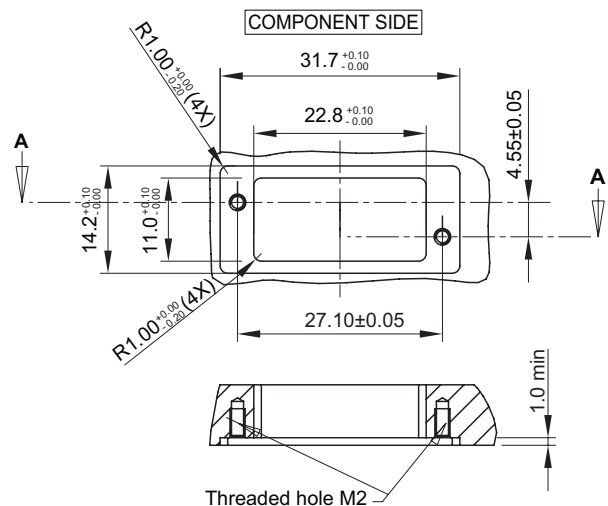

▶ AVAILABLE POLARIZATIONS FOR 12 AND 21 WAYS

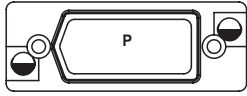

C01

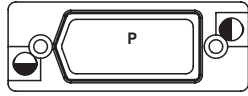

C02



C03

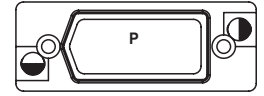

C04

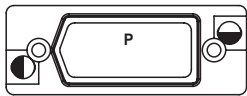
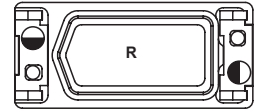
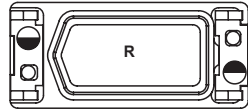
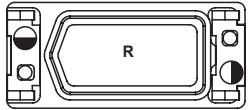
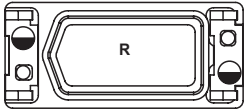

C05

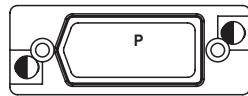

C06



C07

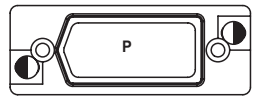

C08

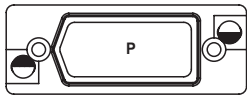
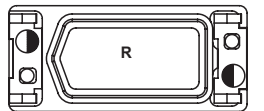
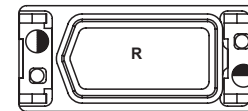
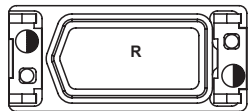
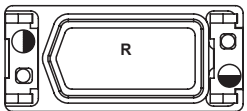

C09

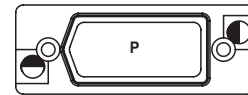

C10

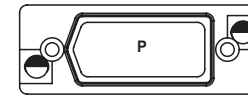

C11

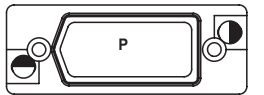

C12

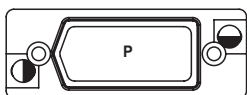
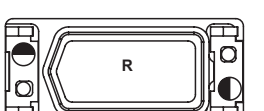
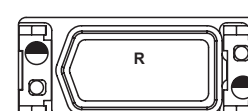
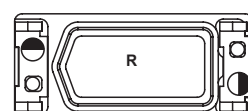
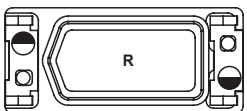

C13

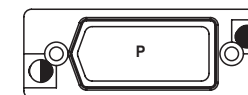

C14

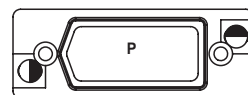

C15

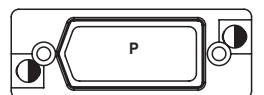

C16

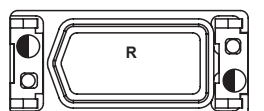
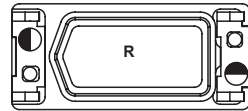
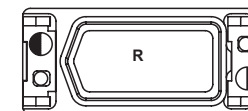
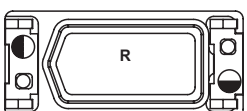

▶ ACCESSORIES

DUST CAP

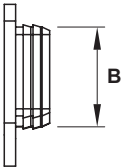
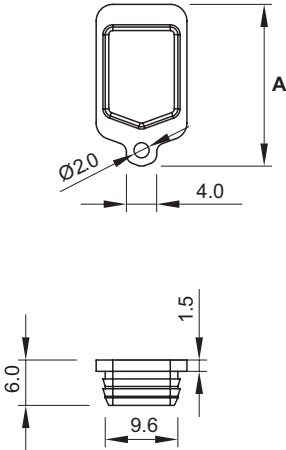

No. of ways	PN	A	B
12	23841	21.4	13.2
21	23840	28	19.8

▶ 30 WAYS PLUG

30 WAYS PLUG - SOLDER CUP TERMINATION

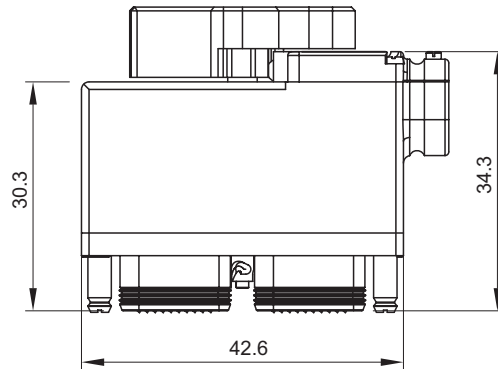
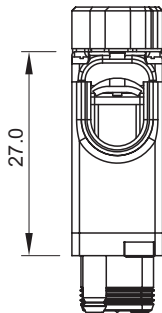
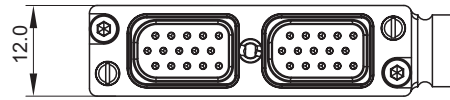

30 WAYS PLUG WITH OVERMOULDING AND CABLING

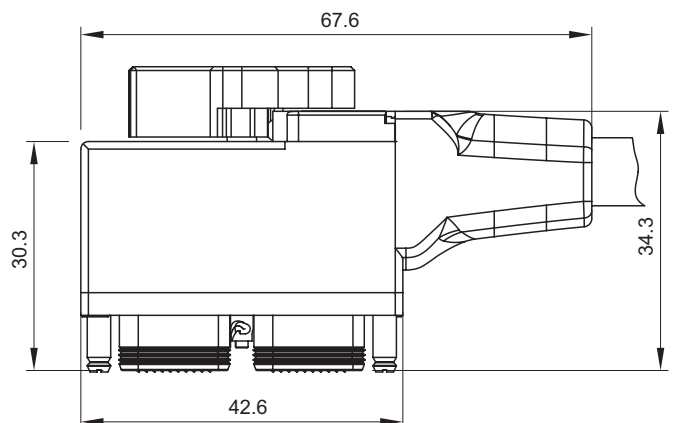
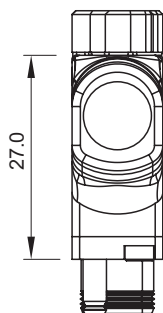
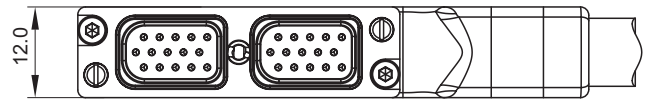

▶ 30 WAYS RECEPTACLE

30 WAYS RECEPTACLE - SOLDER CUP TERMINATION

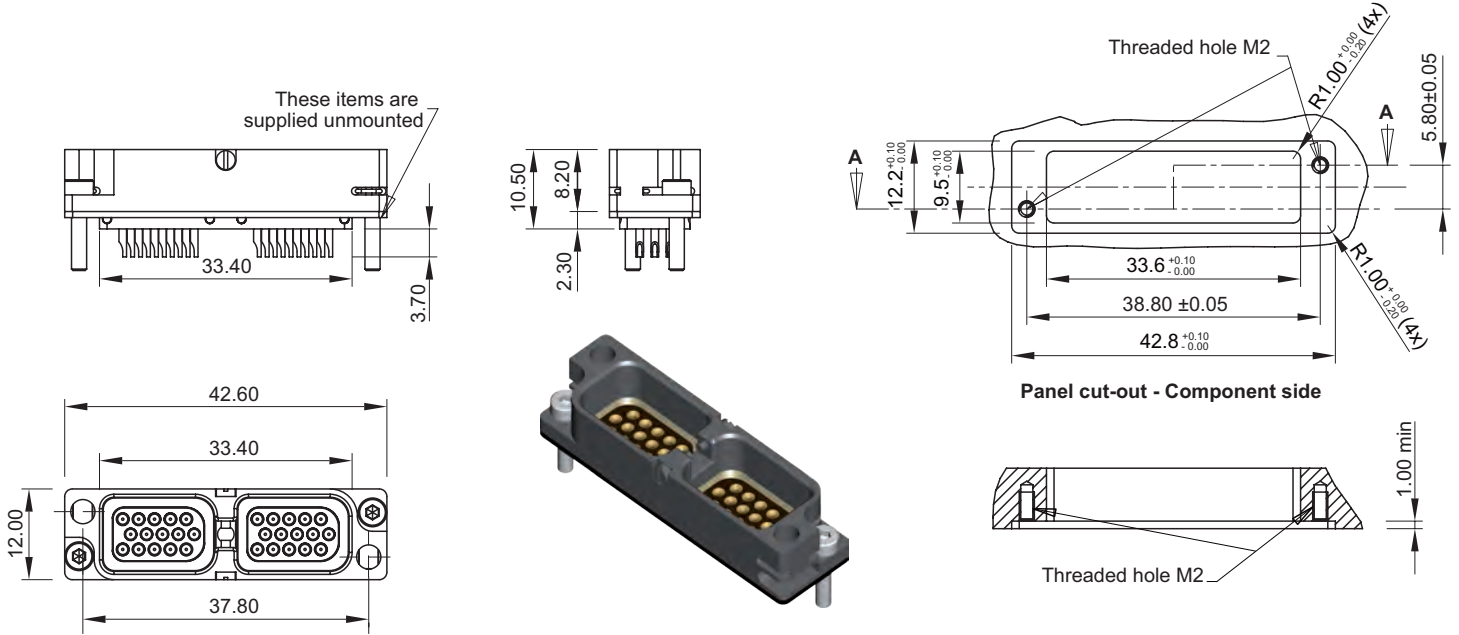

30 WAYS RECEPTACLE - STRAIGHT THROUGH TERMINATION

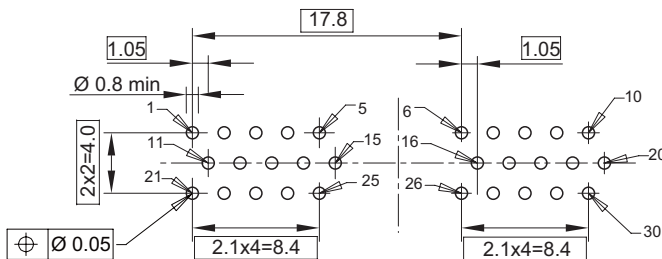
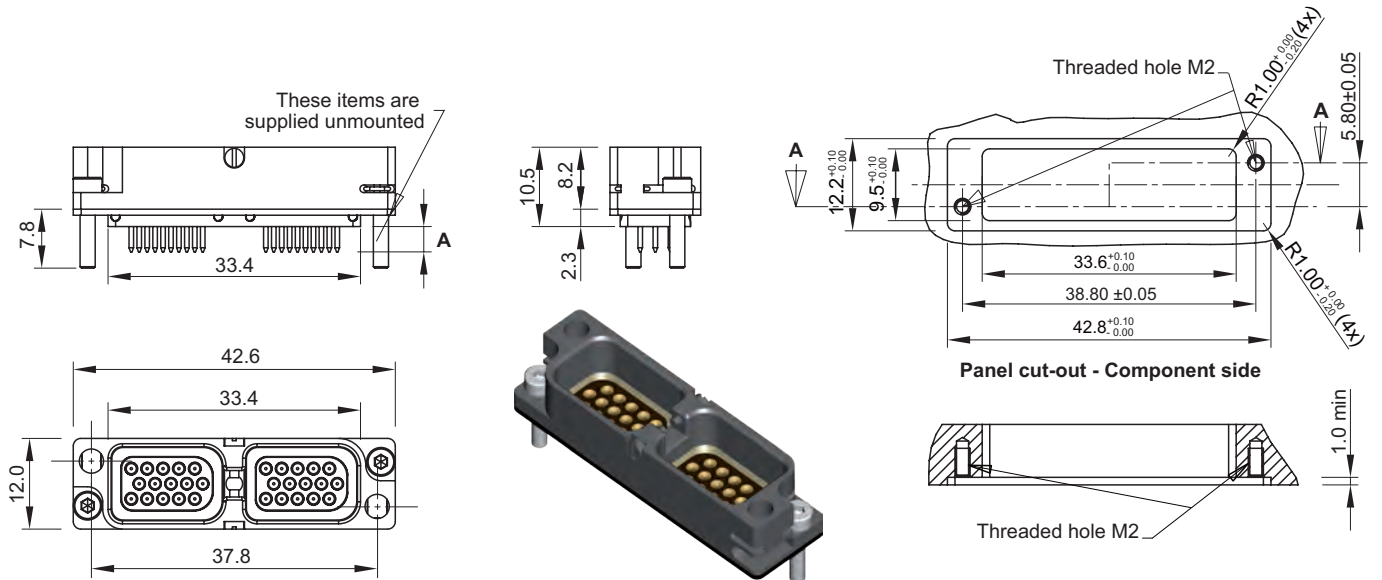

Mounting Pattern - Component side

	A
R30RDC----	3.15
R30RLC----	14

▶ 30 WAYS PLUG - FRONT PANEL MOUNT

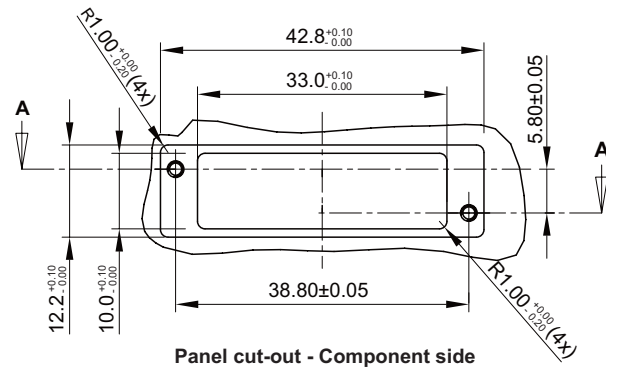
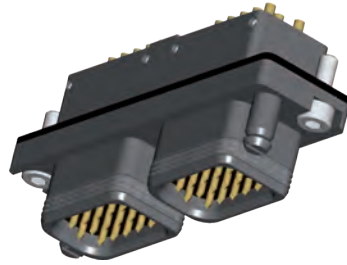
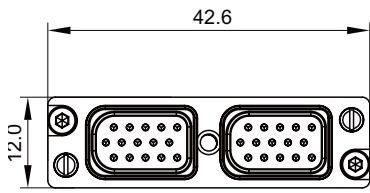

Panel cut-out - Component side

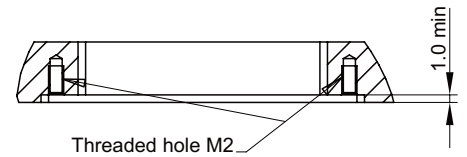
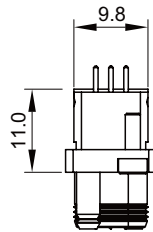
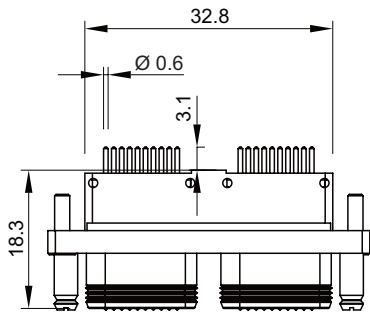

Threaded hole M2

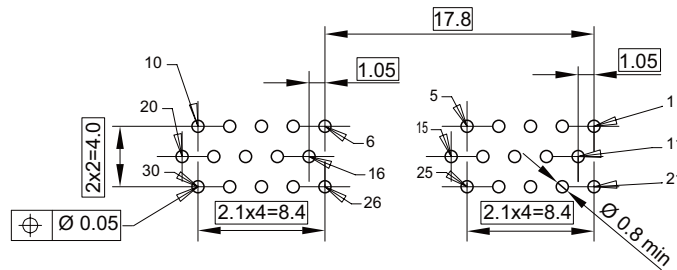

Mounting Pattern - Component side

Disclaimer 2014

All of the information included in this catalogue is believed to be accurate at the time of printing. It is recommended, however, that users should independently evaluate the suitability of each product for their intended application and be sure that each product is properly installed, used and maintained to achieve desired results.

Smiths Connectors makes no warranties as to the accuracy or completeness of the information, and disclaims any liability regarding its use.

Smiths Connectors reserves the right to modify design and specifications, in order to improve quality, keep pace with technological development or meet specific production requirements.

No reproduction or use without express permission of editorial and pictorial content, in any manner.

SMITHS CONNECTORS PRODUCT LINES

PCB



- ▶ Low, medium and high density board-to-board, cable to board and stacking
- ▶ Rugged standard
- ▶ Low profile
- ▶ Signal, power, coaxial & high speed configurations
- ▶ Self configurable board-to-board
- ▶ Spring probe connectors
- ▶ Mixed signal, power and coaxial contact connectors
- ▶ Different termination styles: solder cup, crimp, SMT and SMT flex, press fit, solder dip.

POWER

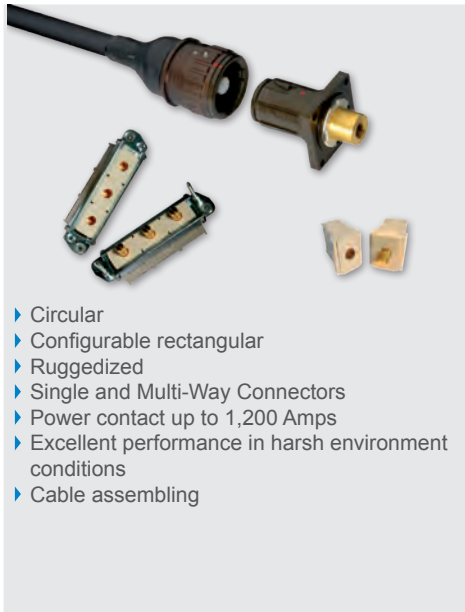

- ▶ Circular
- ▶ Configurable rectangular
- ▶ Ruggedized
- ▶ Single and Multi-Way Connectors
- ▶ Power contact up to 1,200 Amps
- ▶ Excellent performance in harsh environment conditions
- ▶ Cable assembling

EMI/EMP FILTER



- ▶ EMI/RFI filtering and transient protection
- ▶ RoHS compliant solderless filter connectors available
- ▶ Circular, ARINC, D-Subminiature Micro-D
- ▶ Filtered adapters for "bolt on" EMI /EMP solutions
- ▶ Filter hybrid capability

MODULAR/RECTANGULAR



- ▶ Configurable with modules for signal, power, coax, fiber optics and/or pneumatics
- ▶ Easy configuration in a single frame
- ▶ For rack & panel, and cable applications
- ▶ Guided hardware for blind
- ▶ D-sub connectors
- ▶ Micro-D style
- ▶ Signal connectors for hand held and docking stations

CIRCULAR



- ▶ Metal and Plastic
- ▶ Industrial M12, M23, M40, M58
- ▶ Crimp and solder terminations
- ▶ Various types of cable clamps
- ▶ Push Pull/ latch mechanism
- ▶ Color coding

HEAVY DUTY



- ▶ Ultra reliable hyperboloid contact
- ▶ Modular solution: signal, power, data contacts, and fiber optics
- ▶ High resistance in harsh environment
- ▶ EMC shielding
- ▶ Easy cable mounting
- ▶ High pressure up to 35K PSI, 250° C
- ▶ High temperature up to 440° C

SPRING PROBES



- ▶ Z-axis compliant
- ▶ Blind mate engagement
- ▶ Long cycle life
- ▶ High density
- ▶ Extreme miniaturization
- ▶ Printed circuit board test
- ▶ Bare board test
- ▶ Coaxial contacts

MIL/AERO STANDARD

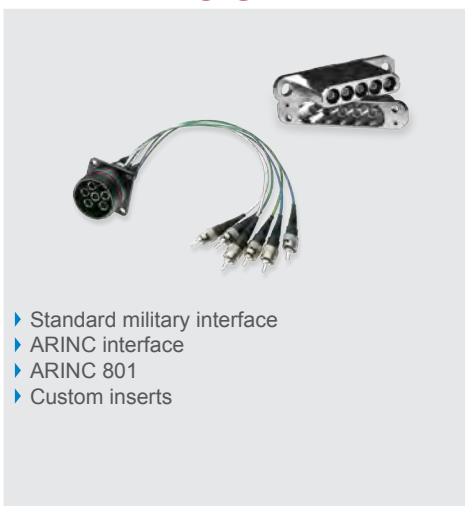

- ▶ Standard military interface
- ▶ ARINC interface
- ▶ ARINC 801
- ▶ Custom inserts

HIGH SPEED COPPER/FIBER



- ▶ Quadrx and Twinax Connectors
- ▶ Rugged D-Sub Connectors
- ▶ ARINC and MIL-STD Contacts
- ▶ Micro Twinax/Quadrx
- ▶ Butt-Joint and Expanded Beam Contacts
- ▶ ARINC 801 Termini
- ▶ Floating Fiber Termini

SMITHS CONNECTORS GLOBAL SUPPORT

AMERICAS

Costa Mesa, CA
Hudson, MA
Kansas City, KS

1.714.371.1100
1.978.568.0451
1.913.342.5544

customerservice@sabritec.com
info@hypertronics.com
info@idinet.com

EUROPE

France
Germany
Italy
United Kingdom

33.2.3296.9176
49.991.250.120
39.10.60361
44.20.8450.8033

info@hypertac.fr
info@hypertac.de
info@hypertac.it
info@hypertac.co.uk

ASIA

Bangalore, India
Shanghai, China
Singapore
Suzhou, China

91.80.2535.7351/52
86.21.3318.4650
65.6846.1655
86.512.6273.1188

info@hypertac.fr
asiacrs@smithsconnectors.com
asiacrs@smithsconnectors.com
asiacrs@smithsconnectors.com

visit us at | smithsconnectors.com |     

Copyright© 2014 Smiths Connectors | All rights reserved