

UTL SERIES



SOURIAU

UL/IEC Power Supply & Power Cable Connectors



Contents

Overview

Typical Applications.....	06
Features & Benefits	07
Range Overview	08
General Technical Characteristics	10

Connector

Overmoulded Cable Assembly	14
3 Contacts + Ground	18
6 Contacts	22

Contacts

Description	28
Contact Plating Selector Guide	29
Contact Selector Guide	30
Packaging	30
Crimp Contacts	31
#16 Coaxial Contacts	33
PCB Contacts	34

Technical information

Tooling	38
Crimping Instructions	40
Handle & Interchangeable Heads	42
Insertion Tool	43
Extraction Tool	43
Mated Connector Length	44
Assembly Instructions	45
Evaluation Kit	49
Rated Current & Working Voltage	52
UV Resistance	53
UL94 + UL1977	54
IEC 61984 with IP Code Explained	57
IEC 61140 Explained	59
What is NEMA Rating ?	60
Ethernet for the Layman	61
RS-485 for the Layman	63

Appendices

#16 Coaxial Contacts - Cabling Notices	66
Glossary of Terms	73
Part Number Index	74

UTL SERIES

UTL Series

Overview

■ Typical Applications	06
■ Features & Benefits	07
■ Range Overview	08
■ General Technical Characteristics	10

Typical Applications

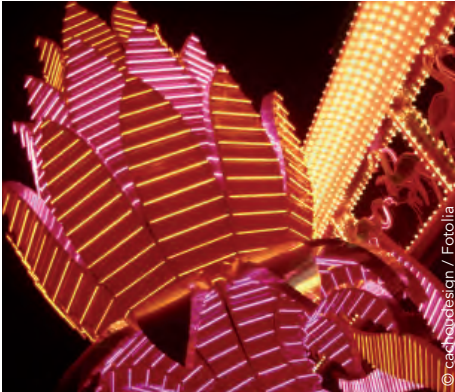

Stage & Light



Energy - Power



Building Automation & Control



Telecom - Data infrastructure

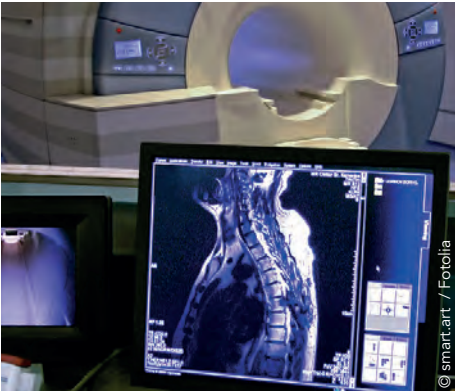

Medical



Instrumentation & Measurement

Features & Benefits

WATER PROOF

IP68/69K Dynamic Mated & Unmated

Ideal for outdoor and indoor dynamic applications requiring continuous underwater immersion, routine pressure washing and dust protection.

UV RESISTANT

No Degradation - Long Outdoor Life

No mechanical degradation or important color variation due to environmental exposure (F1 material per the UL 746C).

UL/IEC COMPLIANT

Qualified & Certified

- UL file : E169916
 - VDE customer n°: 4282400
-

QUICK RELEASE

Sensitive and audible click

Unique "Keyhole" shape of the connector allows users to mate and unmate in blind conditions with audible click confirming connection. Easy to use thumb latch design reduced labor and time during installations.

COST SAVINGS

Mixed Power & Signal Layouts

Power supply and signal transmission can be combined in a unique interconnect solution to reduce system complexity and minimize component/installation costs.



HARNESS
Overmould
(straight or right angle)



PLUG
UTL6

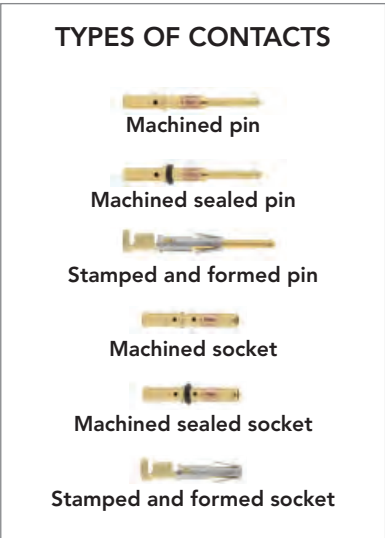

RECEPTACLES

In line - UTL1

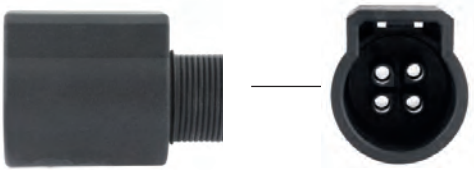

Jam nut - UTL7



Square flange - UTL0

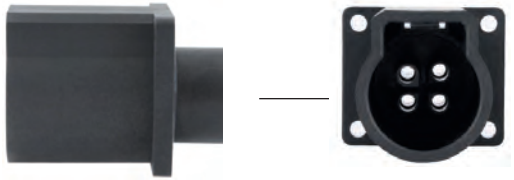

HARNESS
Overmould
(straight or right angle)





Description

- The UTL Series is a plastic connector range that meets current safety standards.
- The stainless steel latch coupling system is simple to use. With only 1 finger, connectors are mated with an audible and sensitive "click".
- The "Key hole" of the coupling system allows blind mating. In dark conditions the mechanical discriminations allow easy mating to avoid connector damage.
- The UTL Series is rated at IP68/69K even in dynamic conditions and remains sealed even when used continuously underwater or cleaned using a high pressure hose and cable is moving.
- The UTL Series uses an outdoor rated material per Underwriters Laboratories.

Technical Features

Materials

- **Housing:** Thermoplastic
- **Contacts:** See page 31
- **Latch:** Stainless steel
- **Halogen free**

Electrical

- UL: 600V 16A UL94 5VA
277V 13A for CBC use
- CN: 600V 13A
277V 10A for CBC use
- IEC: 16A 500V 6KV 4
13A 250V 4KV 4 for CBC use
- Connector specially designed to be engaged or disengaged in normal use when live or under load
- First Mate Last Break contact mating on ground line
- **In accordance with:**
 - IEC60065, IEC60598, UL1598, IEC60320, UL498, UL94, UL746, IEC61076-2-103
 - UL 1977: UL file number E169916

- IEC 61984: IEC file number
4282400-1431-0004/168702



Environmental

- **Operating temperature:**
From -40°C to +105°C for connector
From -25°C to +60°C for cable assemblies due to cable performances: see page 14 for cable assemblies
- **Flammability rating:**
UL 94 5VA
- **Salt spray:**
≥1000 hours
- **UV resistant:**
No mechanical degradation or important color variation due to environmental exposure (F1 material per the UL 746C)
- **Sealing:**
 - IP68/69K mated with standard contacts
 - IP68 even unmated with sealed contacts (see page 31)

Fluid resistance:

- Gas and oil
- Mineral oil
- Acid bath
- Basic bath

- **RoHS compliant & conforms to the Chinese standard SJ/T1166-2006**
(Chinese RoHS equivalent)



Mechanical

- **Durability:**
1.000 matings & unmatings
- **Coupling system:**
 - Sensitive and audible click
 - Blind mating
- **Touchproof:**
IP2X in unmated conditions (connector equipped with socket contacts)

UTL SERIES

UTL Series

Connector

■ Overmoulded Cable Assembly	14
■ 3 Contacts + Ground	
103G1: 16A 500V.....	18
■ 6 Contacts	
102G1W3: 16A 500V.....	22

Overmoulded Cable Assembly

SOURIAU has provided connectors for various applications for more than 90 years and has been used in the most extreme environments. Conscious about the difficulty in finding a quick and reliable harness manufacturer, we began our own in-house Overmoulded Cable Assembly production. It allows customers to reduce the number of suppliers and to take advantage of the “best in class” quality of the SOURIAU group. Overmoulding is a process that further enhances the sealing properties and helps to minimize stress on the cable termination to the connector. In addition, the wires are encapsulated inside the molding which creates a barrier preventing liquid/moisture from entering the equipment through the connector or cable jacket if breached.



How to choose the outer jacket material

 Please consult us

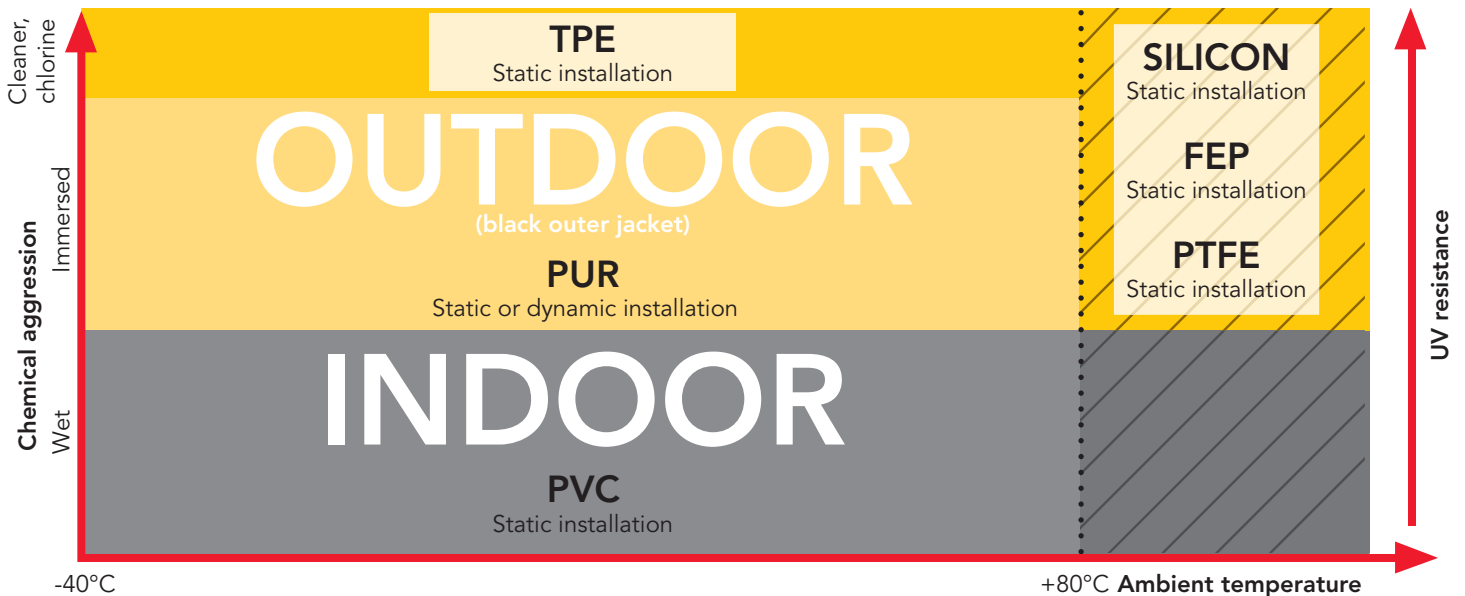

Overmoulding Description

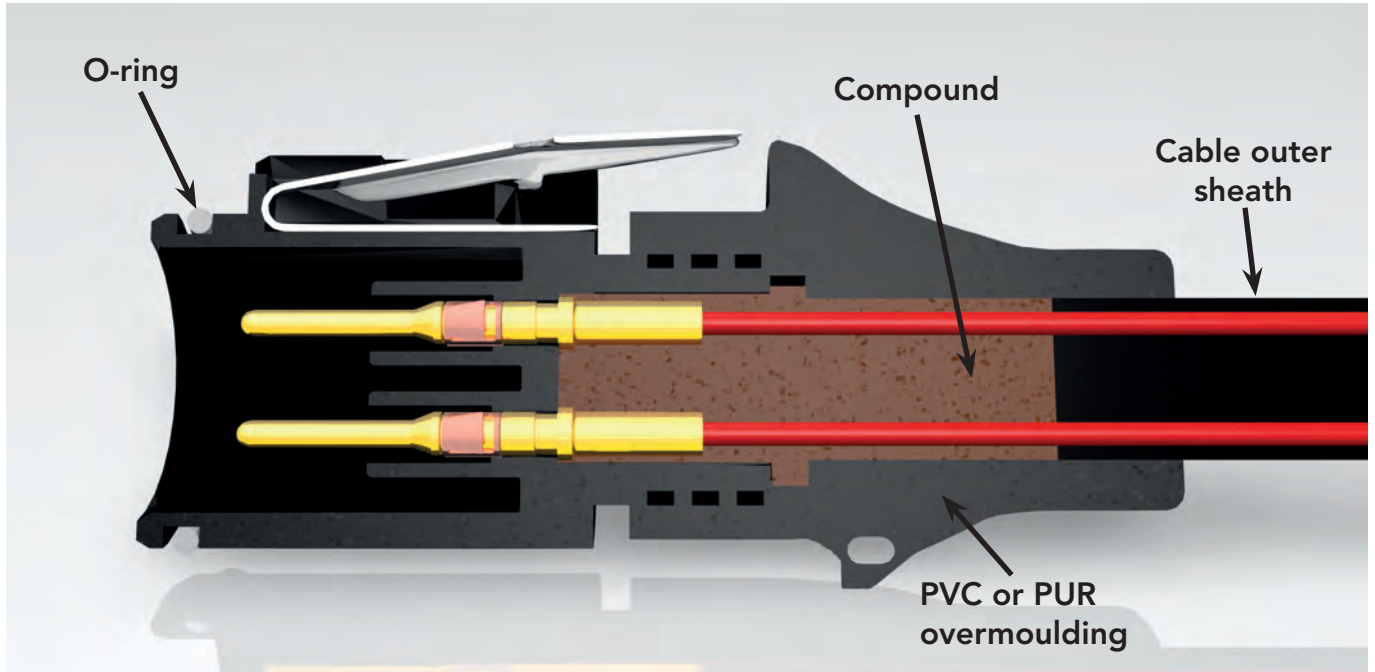

Connector with cable gland backshell

GOOD



Overmoulded connector

BEST

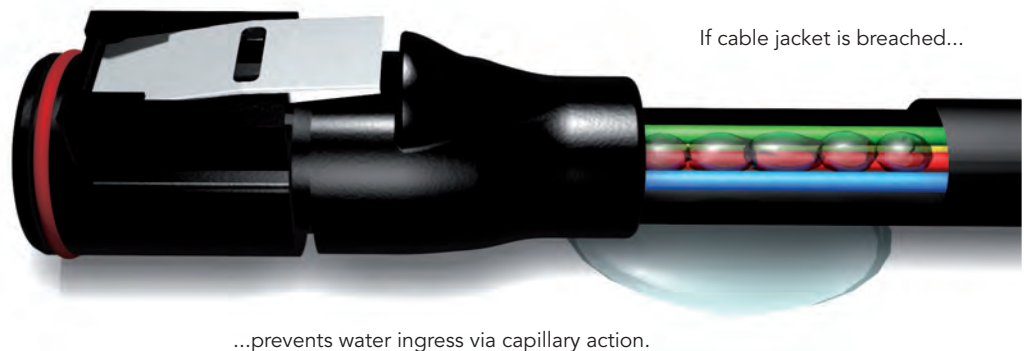

UTL Overmoulded Cable Assembly (Continued)



Description

Cable - 3 + ground

- Outer sheath: rubber compound EM2 in acc. to HD 22.1 that is VDE 0282 part 1
- Outer sheath color: black
- Flame retardant in acc. to IEC 60332-1-2 resp. VDE 0482 part 332-1-2
- Resistant to Oil, Solvents, Water, Ozone, aging and abrasion

Cable - 6 pos.

- Signal: 1 x 2 x 0.22 + shielding
Power: 3G1.5
- Outer sheath: PUR RAL9005
- Outer sheath color: black
- Core section: 0.22 mm² and 1.5 mm²

Specifications

PLATING	SALT SPRAY	DEGREE	WATERPROOF	COUPLING
No plating	≥1000 H	Up to + 60° C ⁽¹⁾ with 103G1 Up to + 70° C ⁽¹⁾ with 102G1W3	IP68/69K dynamic mated & unmated	1 000 matings/unmatings

⁽¹⁾ See page 17 for more information

Cable Information

Rated voltage:	U0/U: 450/750 V
Wire section:	3 + ground: 2.5 mm ² 6 pos.: 1.5 mm ² (power), 0.22 mm ² (signal)
Temperature:	3 + ground: flexible use and fixed installation -25° C up to +60° C 6 pos.: flexible use -15° C up to +70° C, fixed installation -30° C up to +70° C
Harmonized reference:	3 + ground: H07 RNF 4G x 2.5 6 pos.: Not Applicable

Standardization of European cable - DIN VDE 0281/DIN VDE 0282/DIN VDE 0292

Harmonized wire coding system

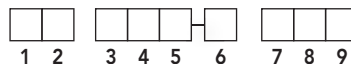

1. Basic type	2. Working voltage	3. Insulating	4. Sheath-cladding material	5. Special features	6. Conductor types	7. Number of conductors	8. Protective conductor	9. Conductor cross-sectional
H: Harmonized Type	03: 300/300V	V: PVC	V: PVC	H: Ribbon cable, separable	U: Single wire		X: Without protective conductor	Area specified in mm ²
A: National Type	05: 300/500V	R: Rubber	R: Rubber	H2: Ribbon cable non-separable	R: Multi-wire		G: With protective conductor	
	07: 450/750V	S: Silicone Rubber	N: Cloroprene Rubber		K: Fine wire (permanently installed)			
			J: Glass-filament braiding		F: Fine wire (flexible)			
			T: Textile braiding		H: Super fine wire			
					Y: Tinsel strand			

Example: Harmonized type, 450/750V, rubber insulating, Cloroprene rubber sheath-cladding, Fine wire, 3x1.5 cross-sectional: H07RNF3x1.5

103G1 (shell size 10, 3 + ground, 4x#16)

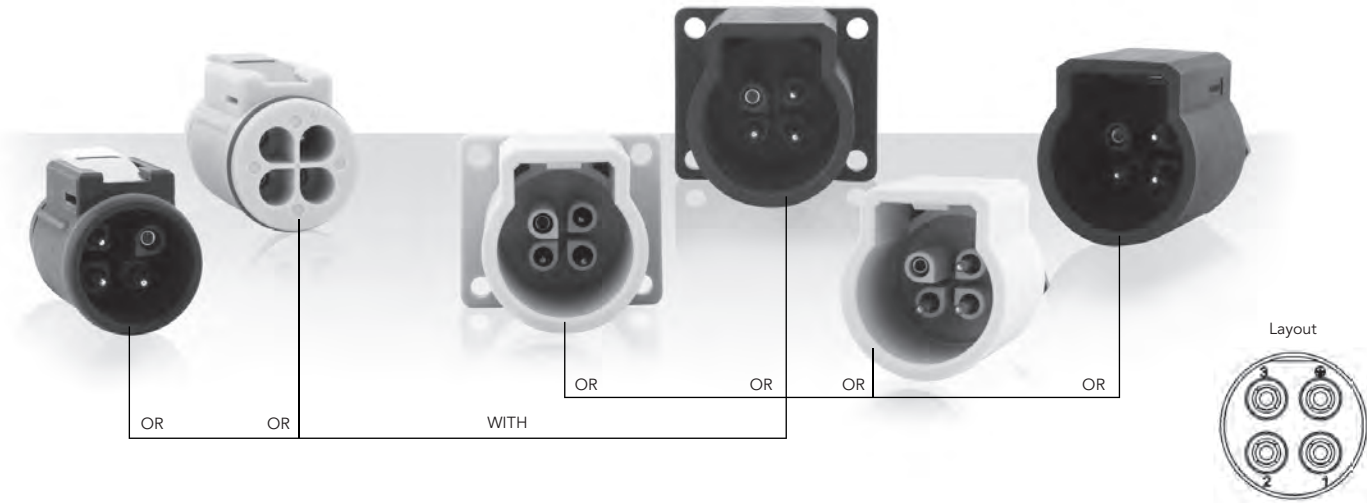

Connector Part Number

Contact type	Connector type	Part number			
		Male insert		Female insert	
		Black color	Grey color	Black color	Grey color
Crimp contacts supplied separately see page 21	Square flange receptacle	UTL0103G1P	UTL0103G1P03	UTL0103G1S	UTL0103G1S03
	Plug	UTL6103G1P	UTL6103G1P03	UTL6103G1S	UTL6103G1S03
	Jam nut receptacle	UTL7103G1P	UTL7103G1P03	UTL7103G1S	UTL7103G1S03
	In line receptacle	UTL1103G1P	UTL1103G1P03	UTL1103G1S	UTL1103G1S03

Overmoulded Cable Assembly Part Number

Layout	Description	Connector and Overmould type		Length*	
		Connector	Overmould type	1m	2m
103G1	In line	Male In line receptacle	Straight	HAUTL13G1PS1M	HAUTL13G1PS2M
		Male In line receptacle	Right angle	HAUTL13G1PR1M	HAUTL13G1PR2M
		Female In line receptacle	Straight	HAUTL13G1SS1M	HAUTL13G1SS2M
		Female In line receptacle	Right angle	HAUTL13G1SR1M	HAUTL13G1SR2M
	Plug	Male plug	Straight	HAUTL63G1PS1M	HAUTL63G1PS2M
		Male plug	Right angle	HAUTL63G1PR1M	HAUTL63G1PR2M
		Female plug	Straight	HAUTL63G1SS1M	HAUTL63G1SS2M
		Female plug	Right angle	HAUTL63G1SR1M	HAUTL63G1SR2M

* : Other lengths consult us

Evaluation kit - See page 49

103G1 (shell size 10, 3 + ground, 4x#16)

Dimensions (For mated connector lengths see page 44)

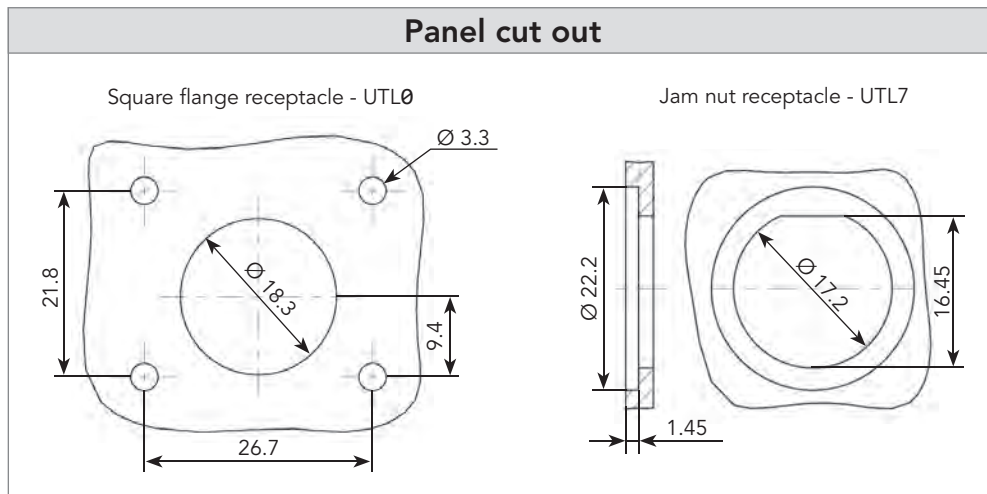
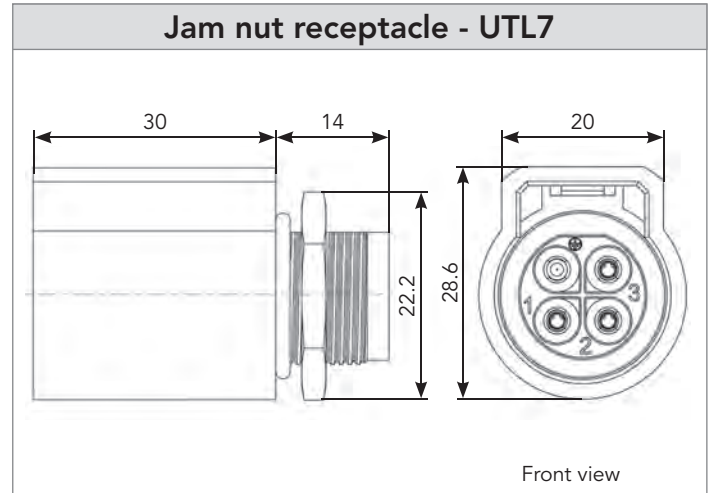
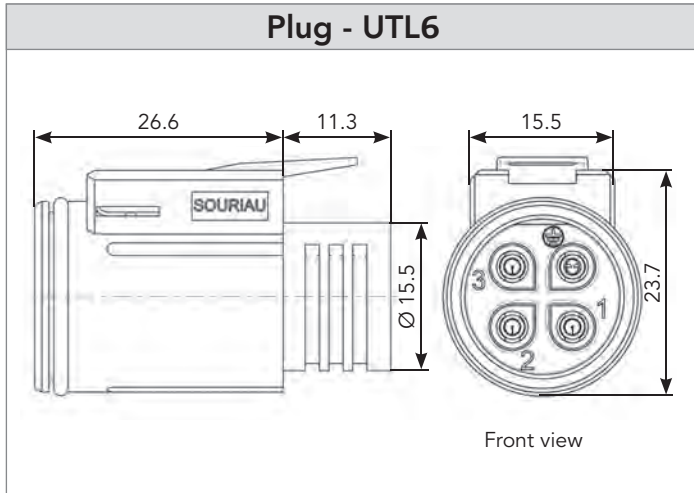
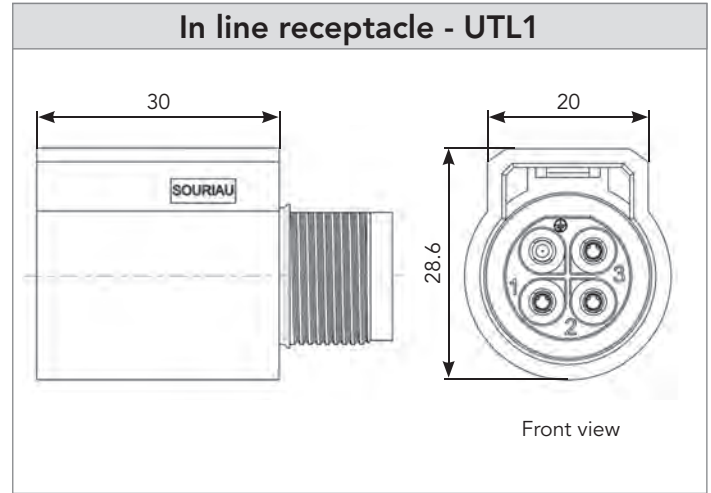
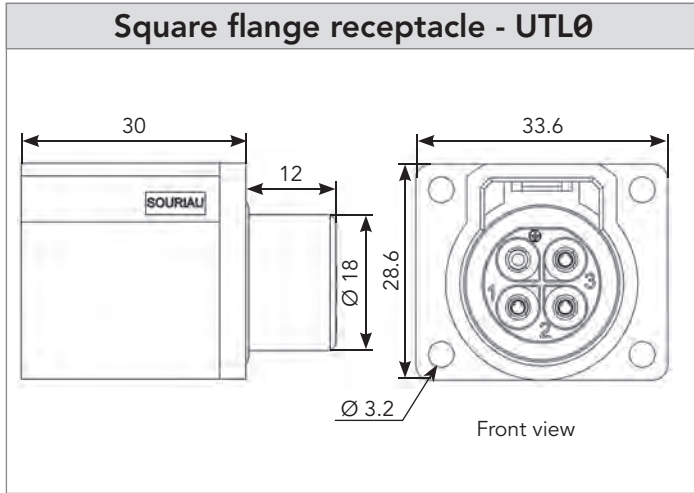

Note: all dimensions are in mm

103G1 (shell size 10, 3 + ground, 4x#16)

Accessories and Tooling

Dustcap for plug

IP67



Part number
UTL610DCG

Dustcap for receptacle

IP67



Part number
UTL10DCG

Handle (without head)



Part number
SHANDLES

Tool kit



Part number
TOOLKIT

Dustcap for male receptacle

IP68/69K



Part number
UTL103G1PDCG68

Dustcap for female receptacle

IP68/69K



Part number
UTL103G1SDCG68

Grommet



Part number
SWSFILLERPLUG

See instruction page 48

Extraction Tool #16



Part number
RX2025GE1

Head Crimp Tooling (without handles)



Contacts	Contact size	Part number of head
RM/RC 28M1K ⁽¹⁾	Standard contacts #16 Ø 1.6mm	S16RCM20*
RM/RC 24M9K ⁽¹⁾		S16RCM20*
RM/RC 20M13K ⁽¹⁾		S16RCM20*
RM/RC 20M12K ⁽¹⁾		S16RCM20*
RM/RC 16M23K ⁽¹⁾		S16RCM16*
RM/RC 14M30K ⁽¹⁾		S16RCM14*
SM/SC 24ML1TK6 ⁽¹⁾		S16SCM20*
SM/SC 20ML1TK6 ⁽¹⁾		S16SCM20*
SM/SC 16ML1TK6 ⁽¹⁾		S16SCML1*
SM/SC 14ML1TK6 ⁽¹⁾		S16SCML1*
SM/SC 16ML11TK6 ⁽¹⁾		S16SCML11*
SM/SC 16M25K		S16RCM1625*
SM/SC 14M25K		S16RCM1425*
RMDXK10D28K		Coaxial contacts #16 Ø 1.6mm
RCDXK1D28K		
RM/RC DX60xxD28K		
RM/RC DXK10D28 + york090		
RM/RC DX60xxD28		

(1): Example of plating, for other plating options see page 30
* Heads to be used with handle PN: SHANDLES



103G1 (shell size 10, 3 + ground, 4x#16)

Contacts

#16	Contact type	AWG	Part number		Max wire Ø	Max insulator Ø
			Male	Female		
Crimp	Machined	30-28	RM28M1K ⁽¹⁾	RC28M1K ⁽¹⁾	0.55	1.00
		26-24	RM24M9K ⁽¹⁾	RC24M9K ⁽¹⁾	0.80	1.60
		22-20	RM20M13K ⁽¹⁾	RC20M13K ⁽¹⁾	1.15	1.80
		22-20	RM20M12K ⁽¹⁾	RC20M12K ⁽¹⁾	1.15	2.20
		20-16	RM16M23K ⁽¹⁾	RC16M23K ⁽¹⁾	1.80	3.20
		16-14	RM14M30K ⁽¹⁾	RC14M30K ⁽¹⁾	2.30	3.20
	Machined Sealed (with O-Ring for IP68/69K unmated)	20-16	RM16M25K	RC16M25K	1.80	3.20
		16-14	RM14M25K	RC14M25K	2.28	3.20
	Stamped & Formed Reeled Contacts <i>See note (2) for loose piece</i>	26-24	SM24M1TK6 ⁽¹⁾⁽²⁾	SC24M1TK6 ⁽¹⁾⁽²⁾	-	0.90-1.60
		22-20	SM20M1TK6 ⁽¹⁾⁽²⁾	SC20M1TK6 ⁽¹⁾⁽²⁾	-	1.20-2.10
		18-16	SM16M1TK6 ⁽¹⁾⁽²⁾	SC16M1TK6 ⁽¹⁾⁽²⁾	-	3.20
		18-16	SM16M11TK6 ⁽¹⁾⁽²⁾	SC16M11TK6 ⁽¹⁾⁽²⁾	-	3.00
14		SM14M1TK6 ⁽¹⁾⁽²⁾	SC14M1TK6 ⁽¹⁾⁽²⁾	-	3.20	
Coaxial	Cable Multipiece	see pages 33, 66 to 67	RMDXK10D28	RCDXK1D28	-	-
	Cable Monocrimp		RMDX60xxD28	RCDX60xxD28	-	-
	Twisted pair Multipiece		RMDXK10D28 + york090	RCDXK1D28 + york090	-	-
	Twisted pair Monocrimp		RMDX60xxD28	RCDX60xxD28	-	-

(1): Example of plating, for other plating options see page 30

(2): For loose piece contact packaging, place "L" in part number. Example: SM20ML1TK6

Note: all dimensions are in mm

REMINDER

Plugs and receptacles have to be equipped with both contact genders.

EX: UTL6103G1P = 3 x SM16M1S31 + 1 x SC16M1S31

Electrical characteristics

UL
600V 16A UL94 5VA
277V 13A for CBC use

CN
600V 13A
277V 10A for CBC use

IEC
16A 500V 6KV 4
13A 250V 4KV 4 for CBC use

UTL103G1 derating curves

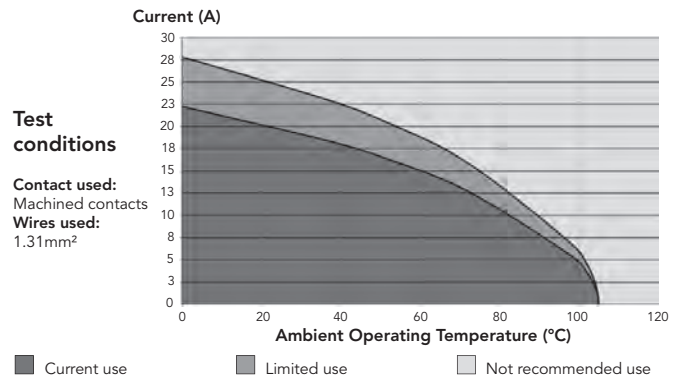

102G1W3 (shell size 10, 3x#16 + 3x#20)

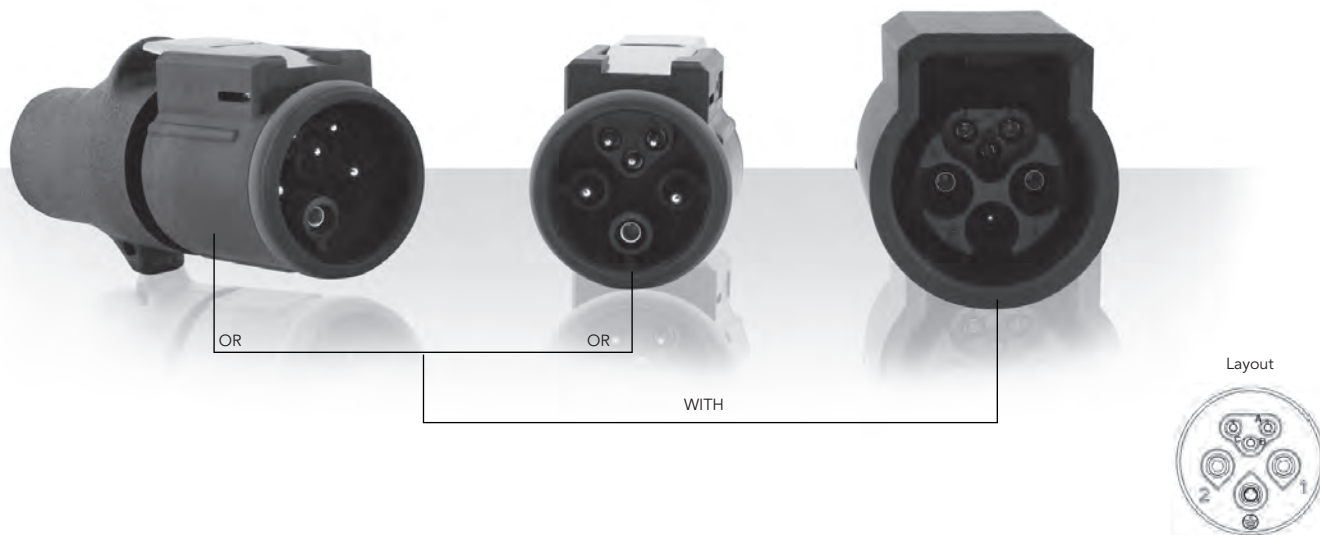

Connector Part Number

Contact type	Connector type	Part number			
		Male insert		Female insert	
		Black color	Grey color	Black color	Grey color
Crimp contacts supplied separately see page 25	Plug	UTL6102G1W3P	UTL6102G1W3P03	UTL6102G1W3S	UTL6102G1W3S03
	Jam nut receptacle	UTL7102G1W3P	UTL7102G1W3P03	UTL7102G1W3S	UTL7102G1W3S03
	In line receptacle	UTL1102G1W3P	UTL1102G1W3P03	UTL1102G1W3S	UTL1102G1W3S03
-	Terminating resistance plug - 120Ω	UTL6102G1W3PCDMX	-	UTL6102G1W3SCDMX	-
	Terminating resistance receptacle - 120Ω	UTL1102G1W3PCDMX	-	UTL1102G1W3SCDMX	-

Overmoulded Cable Assembly Part Number

Layout	Description	Connector and Overmould type		Length*	
		Connector	Overmould type	1m	2m
102G1W3	In line	Male In line receptacle	Straight	HAUTL12G1W3PS1M	HAUTL12G1W3PS2M
		Male In line receptacle	Right angle	HAUTL12G1W3PR1M	HAUTL12G1W3PR2M
		Female In line receptacle	Straight	HAUTL12G1W3SS1M	HAUTL12G1W3SS2M
		Female In line receptacle	Right angle	HAUTL12G1W3SR1M	HAUTL12G1W3SR2M
	Plug	Male plug	Straight	HAUTL62G1W3PS1M	HAUTL62G1W3PS2M
		Male plug	Right angle	HAUTL62G1W3PR1M	HAUTL62G1W3PR2M
		Female plug	Straight	HAUTL62G1W3SS1M	HAUTL62G1W3SS2M
		Female plug	Right angle	HAUTL62G1W3SR1M	HAUTL62G1W3SR2M

* : Other lengths consult us

Evaluation kit - See page 50

102G1W3 (shell size 10, 3x#16 + 3x#20)

Dimensions (For mated connector lengths see page 44)

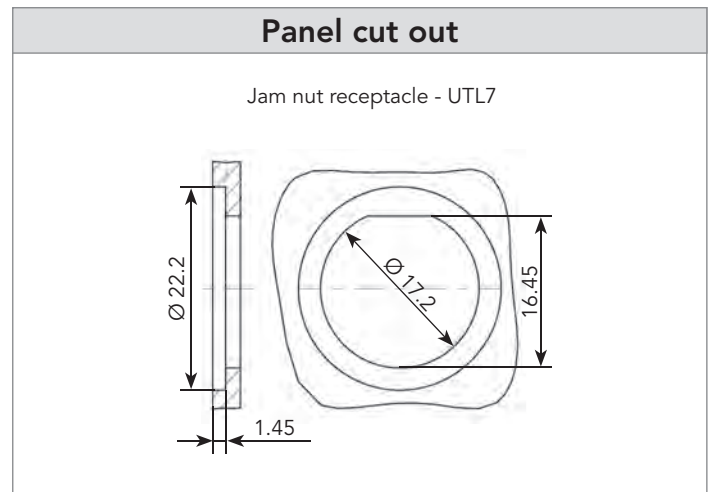
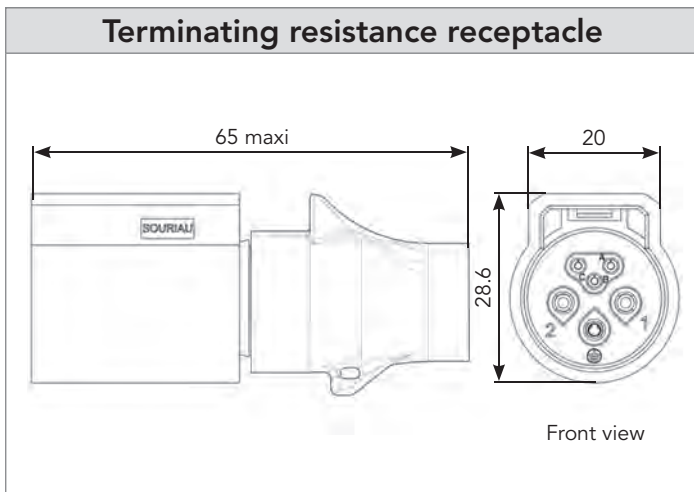
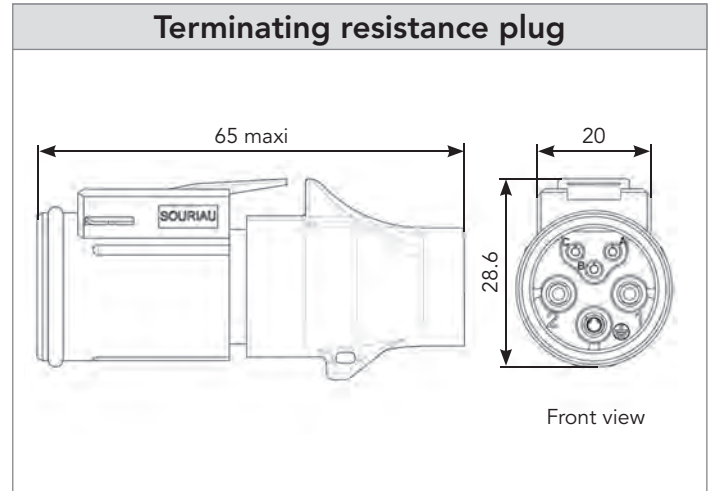
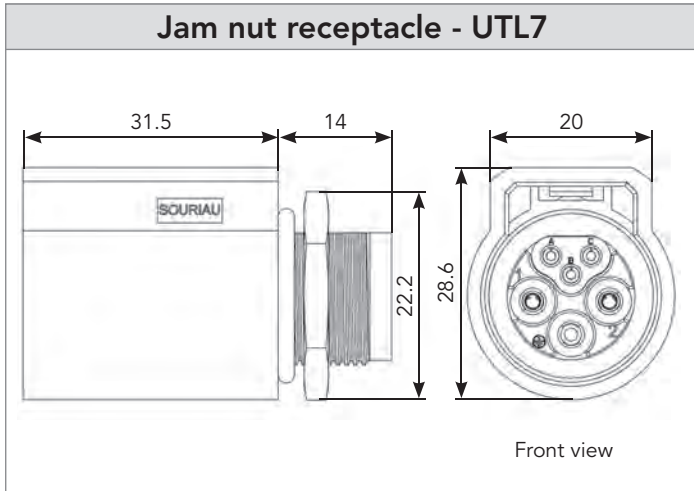
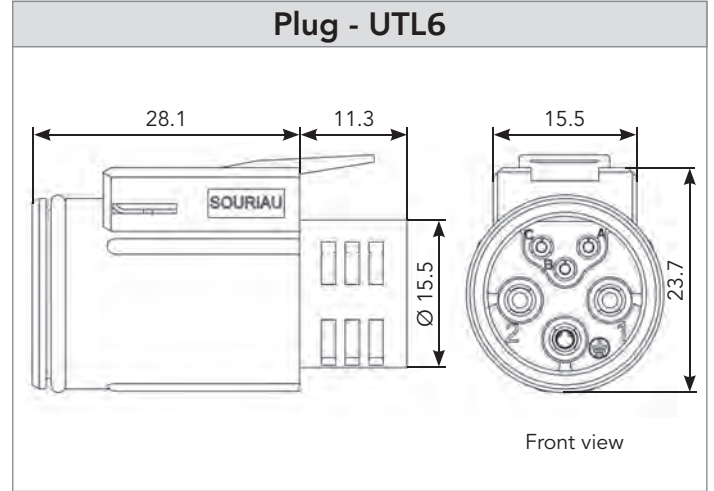
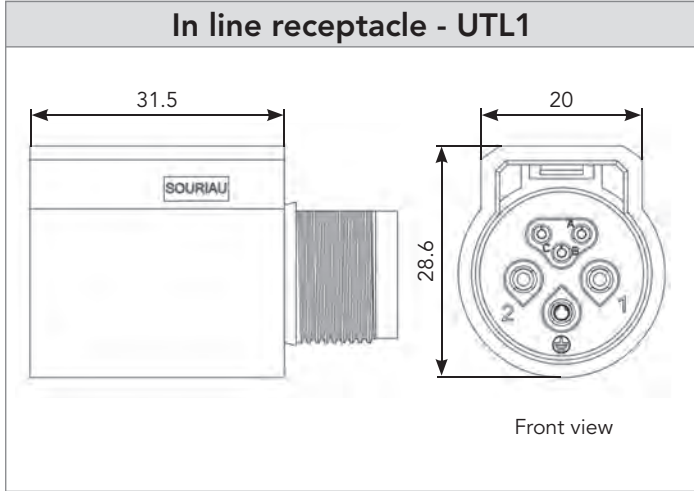

Note: all dimensions are in mm

102G1W3 (shell size 10, 3x#16 + 3x#20)

Accessories and Tooling

Dustcap for plug

IP67



Part number
UTL610DCG

Dustcap for receptacle

IP67



Part number
UTL10DCG

Handle (without head)



Part number
SHANDLES

Tool kit



Part number
TOOLKIT

Dustcap for male receptacle

IP68/69K



Part number
UTL102G1W3PDCG68

Dustcap for female receptacle

IP68/69K



Part number
UTL102G1W3SDCG68

Extraction Tool #16



Part number
RX2025GE1

Extraction Tool #20



Part number
RX20D44

Head Crimp Tooling (without shandles)

Contacts	Contact size	Part number of head
RM/RC 24W3K ⁽¹⁾	Standard contacts #20 Ø 1mm	S20RCM*
RM/RC 20W3K ⁽¹⁾		S20RCM*
RM/RC 18W3K ⁽¹⁾		S20RCM*
SM/SC 24WL3 ⁽¹⁾⁽²⁾		S20SCM20*
SM/SC 20WL3 ⁽¹⁾⁽²⁾		S20SCM20*
RM/RC 28M1K ⁽¹⁾	Standard contacts #16 Ø 1.6mm	S16RCM20*
RM/RC 24M9K ⁽¹⁾		S16RCM20*
RM/RC 20M13K ⁽¹⁾		S16RCM20*
RM/RC 20M12K ⁽¹⁾		S16RCM20*
RM/RC 16M23K ⁽¹⁾		S16RCM16*
RM/RC 14M30K ⁽¹⁾		S16RCM14*
SM/SC 24ML1TK6 ⁽¹⁾		S16SCM20*
SM/SC 20ML1TK6 ⁽¹⁾		S16SCM20*
SM/SC 16ML1TK6 ⁽¹⁾		S16SCML1*
SM/SC 14ML1TK6 ⁽¹⁾		S16SCML1*
SM/SC 16ML11TK6 ⁽¹⁾		S16SCML11*
SM/SC 16M25K		S16RCM1625*
RMDXK10D28K		Coaxial contacts #16 Ø 1.6mm
RCDXK1D28K		
RM/RC DX60xxD28K		
RM/RC DXK10D28 + yorK090		
RM/RC DX60xxD28		

(1): Example of plating, for other plating options see page 30
 (2): loose contact
 * Heads to be used with handle PN: SHANDLES



102G1W3 (shell size 10, 3x#16 + 3x#20)

#20	Contact type	AWG	Part number		Max wire Ø	Max insulator Ø
			Male	Female		
Crimp	Machined	26-24	RM24W3K ⁽¹⁾	RC24W3K ⁽¹⁾	0.80	1.60
		22-20	RM20W3K ⁽¹⁾	RC20W3K ⁽¹⁾	1.15	1.60
		20-18	RM18W3K ⁽¹⁾	RC18W3K ⁽¹⁾	1.30	2.10
	Stamped & Formed reeled contacts <small>See note (2) for loose piece</small>	26-24	SM24W3TK6 ⁽¹⁾⁽²⁾	SC24W3TK6 ⁽¹⁾⁽²⁾	-	0.90-1.60
		26-24	SM24W3S26 ⁽¹⁾⁽²⁾	SC24W3S25 ⁽¹⁾⁽²⁾	-	0.90-1.60
		22-20	SM20W3TK6 ⁽¹⁾⁽²⁾	SC20W3TK6 ⁽¹⁾⁽²⁾	-	1.20-2.10
		22-20	SM20W3S26 ⁽¹⁾⁽²⁾	SC20W3S25 ⁽¹⁾⁽²⁾	-	1.20-2.10
	#16					
Crimp	Machined	30-28	RM28M1K ⁽¹⁾	RC28M1K ⁽¹⁾	0.55	1.00
		26-24	RM24M9K ⁽¹⁾	RC24M9K ⁽¹⁾	0.80	1.60
		22-20	RM20M13K ⁽¹⁾	RC20M13K ⁽¹⁾	1.15	1.80
		22-20	RM20M12K ⁽¹⁾	RC20M12K ⁽¹⁾	1.15	2.20
		20-16	RM16M23K ⁽¹⁾	RC16M23K ⁽¹⁾	1.80	3.20
		16-14	RM14M30K ⁽¹⁾	RC14M30K ⁽¹⁾	2.30	3.20
	Stamped & Formed Reeled Contacts <small>See note (2) for loose piece</small>	26-24	SM24M1TK6 ⁽¹⁾⁽²⁾	SC24M1TK6 ⁽¹⁾⁽²⁾	-	0.90-1.60
		22-20	SM20M1TK6 ⁽¹⁾⁽²⁾	SC20M1TK6 ⁽¹⁾⁽²⁾	-	1.20-2.10
		18-16	SM16M1TK6 ⁽¹⁾⁽²⁾	SC16M1TK6 ⁽¹⁾⁽²⁾	-	3.20
		18-16	SM16M11TK6 ⁽¹⁾⁽²⁾	SC16M11TK6 ⁽¹⁾⁽²⁾	-	3.00
		14	SM14M1TK6 ⁽¹⁾⁽²⁾	SC14M1TK6 ⁽¹⁾⁽²⁾	-	3.20
		Coaxial	Cable Multipiece	see pages 33, 66 to 67	RMDXK10D28	RCDXK1D28
Cable Monocrimp	RMDX60xxD28		RCDX60xxD28		-	-
Twisted pair Multipiece	RMDXK10D28 + york090		RCDXK1D28 + york090		-	-
Twisted pair Monocrimp	RMDX60xxD28		RCDX60xxD28		-	-

(1): Example of plating, for other plating options see page 30

(2): For loose piece contact packaging, place "L" in part number. Example: SM20ML1TK6

Note: all dimensions are in mm

REMINDER

Plugs and receptacles have to be equipped with both contact genders.
EX: UTL6102W3G1P = 2 x SM16M1TK6 + 1 x SC16M1TK6 + 3 x SM20W3TK6

Electrical characteristics

UL
600V 16A UL94 5VA
277V 13A for CBC use

CN
600V 13A
277V 10A for CBC use

IEC
16A 500V 6KV 4
13A 250V 4KV 4 for CBC use

UTL102G1W3 derating curves

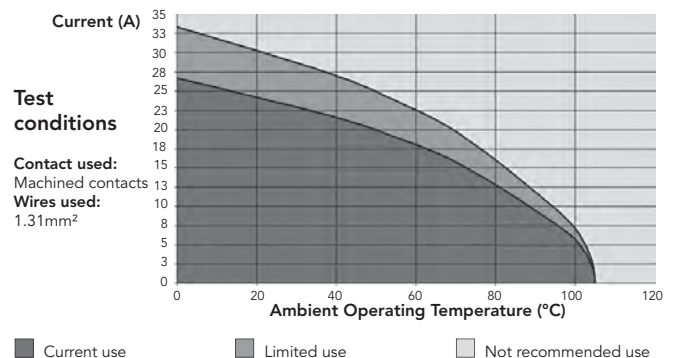

UTL SERIES

Contacts

■ Description	28
■ Contact Plating Selector Guide	29
■ Contact Selector guide	30
■ Packaging	30
■ Crimp Contacts	31
■ #16 Coaxial Contacts	33
■ PCB Contacts	34

Contacts



Description

The UTL series is delivered without contact (crimp version). This series offers the unique possibility to use the same contact in any layout as long as it receives the same active part size.

This provides the benefit of standardization and subsequent reduced inventory costs. In addition, it eliminates the need for added tooling and simplifies the assembly process. SOURIAU contacts are designed for simple snap-in installation and further eliminate the need for insertion tooling.

Crimp contacts are available in different versions:



• Machined



• Stamped & Formed



• Coaxial

In addition, UTL series can obviously be equipped with PCB contacts.

Contact Plating Selector Guide

Once the contact size has been selected, the next step is to decide on which type to use. SOURIAU offers two main types of electrical contacts:

- Machined
- Stamped & Formed

Machined contacts are generally chosen as a better solution for power applications or when lower quantities are needed.

Stamped & formed contacts offer the ability to be crimped automatically which makes them more suitable for high volume production applications.

The next decision to make is: What plating should I choose?

The graph below can help guide you to plating recommendations based on application, mating cycles and current/voltage needs.

Note: do not mix different plating (i.e. tin plated pin contacts with gold plated socket contacts).

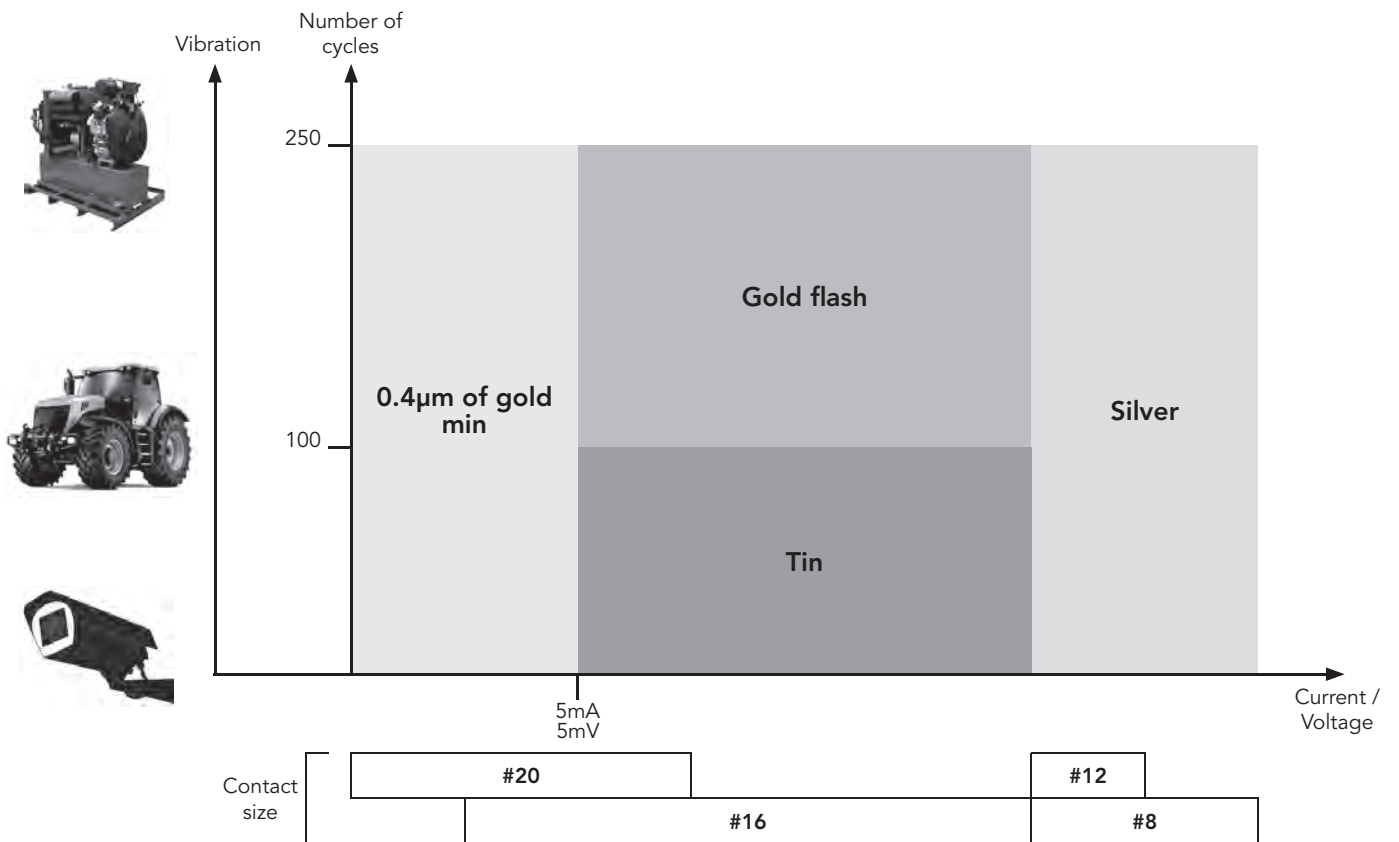

Contact Selector Guide

Contacts Supplied Separately

Electrical characteristics: contact resistance		
#20 Ø1mm	Machined	< 6mΩ
	Stamped and Formed	< 6mΩ
#16 Ø1.6mm	Machined	< 3mΩ
	Stamped and Formed	< 6mΩ

Available platings (contacts supplied separately)	
J	Gold flash over 2µ Ni
K	Min 0.4µ gold over 2µ Ni
S31	Active part: Gold flash over Ni Crimp area: Nickel
S18	Active part: 0.75µ gold min over 2µ Ni Crimp area: 1.3µ tin over Ni Other: Nickel
TK6	2-5µ Sn pre-plated
D70	Superseded by S31
S6	Superseded by S18
Other platings on request (contacts supplied separately)	
T	T: 2µm Ni min all over + 3 to 5 µm Sn all over
D28	0.75µ gold over Ni

Packaging

Due to the wide variety of applications, contact packaging is offered for small series (bulk package) and high volume production (reeled contacts):

Size contacts #20 & #16



- 25 pieces loose package (Stamped & Formed contacts)



- 50 pieces bulk package (Machined contacts)



- 1000 pieces bulk package (Machined contacts)



- 3000 pieces reeled (Stamped & Formed contacts)



- 5000 pieces reeled (Machined contacts)

Crimp Contacts

Standard Version



Contact size	Type	Wire size		Part number		Max wire Ø	Max insulator Ø	Available plating see page 30
		AWG	mm ²	Male	Female			
#20 Ø1 mm	Machined	26-24	0.13-0.20	RM24W3K	RC24W3K	-	1.58 max	K
	Stamped & Formed	26-24	0.13-0.25	SM24W3 ⁻⁽¹⁾	SC24W3 ⁻⁽¹⁾	-	0.89-1.58	TK6 S25 (female) S26 (male)
				SM24WL3 ⁻⁽²⁾	SC24WL3 ⁻⁽²⁾	-		
	Machined	22-20	0.32-0.52	RM20W3K	RC20W3K	-	1.58 max	K
	Stamped & Formed	22-20	0.35-0.5	SM20W3 ⁻⁽¹⁾	SC20W3 ⁻⁽¹⁾	-	1.17-2.08	TK6 S25 (female) S26 (male)
SM20WL3 ⁻⁽²⁾				SC20WL3 ⁻⁽²⁾	-			
Machined	20-18	0.50-0.93	RM18W3K	RC18W3K	-	2.10 max	K	
#16 Ø1.6 mm	Machined	30-28	0.05-0.08	RM28M1-	RC28M1-	0.55	1.1	K, J
	Machined	26-24	0.13-0.2	RM24M9-	RC24M9-	0.8	1.6	K, J
	Stamped & Formed	26-24	0.13-0.25	SM24M1 ⁻⁽¹⁾	SC24M1 ⁻⁽¹⁾	0.89-1.28	Insulation grip	TK6, S31, S18
				SM24ML1 ⁻⁽²⁾	SC24ML1 ⁻⁽²⁾			
	Machined	22-20	0.32-0.52	RM20M13-	RC20M13-	1.18	1.8	K, J
				RM20M12-	RC20M12-		2.2	
	Stamped & Formed	22-20	0.35-0.5	SM20M1 ⁻⁽¹⁾	SC20M1 ⁻⁽¹⁾	1.17-2.08	Insulation grip	TK6, S31, S18
				SM20ML1 ⁻⁽²⁾	SC20ML1 ⁻⁽²⁾			
	Machined	20-16	0.52-1.5	RM16M23-	RC16M23-	1.8	3.2	K, J
	Machined Sealed contact	20-16	0.52-1.5	RM16M25K	RC16M25K	1.8	3.2	K
	Stamped & Formed	18-16	0.8-1.5	SM16M1 ⁻⁽¹⁾	SC16M1 ⁻⁽¹⁾	3.0	No insulation grip	TK6, S31, S18
				SM16ML1 ⁻⁽²⁾	SC16ML1 ⁻⁽²⁾			
	Stamped & Formed	18-16	0.8-1.5	SM16M11 ⁻⁽¹⁾	SC16M11 ⁻⁽¹⁾	2.0-3.0	Insulation grip	TK6, S31, S18
SM16ML11 ⁻⁽²⁾				SC16ML11 ⁻⁽²⁾				
Machined	16-14	1.5-2.5	RM14M30-	RC14M30-	2.28	3.2	K, J	
Stamped & Formed	14	2.0-2.5	SM14M1 ⁻⁽¹⁾	SC14M1 ⁻⁽¹⁾	3.2	No insulation grip	TK6, S31, S18	
			SM14ML1 ⁻⁽²⁾	SC14ML1 ⁻⁽²⁾				
Machined Sealed contact	16-14	1.5-2.5	RM14M25K	RC14M25K	2.28	3.2	K	

(1) contact reeled (2) loose contact
 Example: RM16M3K - Size #16, Machined, AWG20 wire, gold plating.

REMINDER

Plugs and receptacles have to be equipped with both contact genders. Examples:

UTL6103G1P = 3 x SM16M1S31 + 1 x SC16M1S31

UTL6102W3G1P = 2 x SM16M1TK6 + 1 x SC16M1TK6 + 3 x SM20W3TK6

Crimp Contacts (Continued)

First Mate Last Break Contacts

Contact size	Type	Wire size		Part number		Max wire Ø (mm)	Max insulator Ø (mm)	Color band		Available plating see p. 30	
		AWG	mm ²	Male	Female			Front	Rear		
#16 Ø1.6 mm Longer male contact (+1mm)	Machined	30-28	0.05-0.08	RM28M1GE1-	-	0.55	1.1	-	Red	K or J	
		26-24	0.13-0.2	RM24M9GE1-		0.8	1.6	Red	Red		
		22-20	0.32-0.52	RM20M13GE1-		1.18	1.8	2.2	Black		Red
				RM20M12GE1-			Blue	Red			
		20-16	0.52-1.5	RM16M23GE1-		1.8	3.2	-	Red		
		16-14	1.5-2.5	RM14M30GE1-		2.28	-	-	Red		
#16 Ø1.6 mm Shorter female contact (-0.7mm)	Machined	30-28	0.05-0.08	-	RC28M1GE7-	0.55	1.1	-	Blue	K or J	
		26-24	0.13-0.2		RC24M9GE7-	0.8	1.6	Red	Blue		
		22-20	0.32-0.52		RC20M13GE7-	1.18	1.8	2.2	Black		Blue
					RC20M12GE7-		Blue	Blue			
		20-16	0.52-1.5		RC16M23GE7-	1.8	3.2	-	Blue		
		16-14	1.5-2.5		RC14M30GE7-	2.28	-	-	Blue		

How to Make FMLB / LMFB Connection

Contact 1 \ Contact 2	Standard male contact	Standard female contact	Longer male contact
Standard male contact		✓	
Standard female contact	✓		✓ FMLB
Shorter female contact	✓ LMFB		

First Mate Last Break contacts should be chosen only if the cavity is not marked with the ground symbol. For cavities marked with the ground symbol, standard contacts will fulfill the same role as a first mate, last break contact used in a standard cavity.



Ground symbol

#16 Coaxial Contacts

Coaxial Contact Range

Note: Coax contacts cannot be used in the ground cavity
 We provide 2 types of coaxial contacts suitable for 50 or 75Ω, coaxial cable or twisted pair cable.

Monocrimp Coaxial cContact

- The monocrimp one-piece coaxial contacts offer high reliability plus the economic advantage of a 95% reduction in installation time over conventional assembly methods.
- This economy is achieved by simultaneously crimping both the inner conductor and outer braid or drain wire.



Multipiece Crimp Coaxial Contact

- The inner conductor and outer braid is crimped individually.
- The thermoplastic insulating bushing in the outer body is designed to accept and permanently retain the inner contact.
- An outer ferrule is used to connect the braid to the outer contact and provide cable support to ensure against bending and vibration.



Suitable for Coaxial Cable or Twisted Cable

- For jacket diameter from 1.78 to 3.05mm
 Inner conductor up to 2.44mm diameter



- For jacket diameter from 0.64 to 1.45mm
 Inner conductor from AWG30 to AWG24



Contacts for Coaxial Cable Summary

Contact type	Contact range		Contact part number with cable combination	Cabling notice
	Male contact	Female contact		
Multipiece	RMDXK10D28	RCDXK1D28	See page 66	See pages 70 & 71
Monocrimp	RMDX60xxD28	RCDX60xxD28		See page 72

Contacts for Twisted Pairs Cable Summary

Contact type	Contact range		Contact part number with cable combination	Cabling notice
	Male contact	Female contact		
Multipiece	RMDXK10D28 + YORK090	RCDXK1D28 + YORK090	See page 67	See page 68
Monocrimp	RMDX60xxD28	RCDX60xxD28		See page 69

PCB Contacts for 3 + ground (103G1)

PCB Contacts for 3 + Ground (103G1)

PCB Soldering

UTL range can be carried out with a wave soldering process, but not reflow soldering process. All high temperature processes are prohibited.



Contact size	Connetor type	Part number contact		Plating see page 30
		Male	Female	
#16 Ø1.6mm	Male insert	RM20M12E8K	RC20M12E84K	K
	Female insert	RM20M12E8K	RC20M12E83K	

Nominal Length

Dimension of dipsolder contacts out of connector (contacts to be ordered separately).

UTL7 female

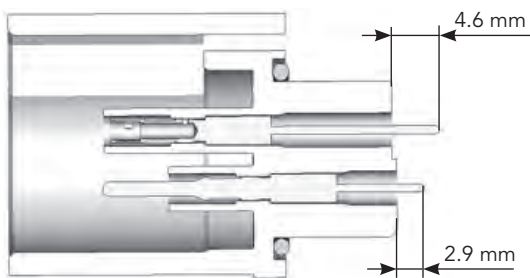

UTL7 male

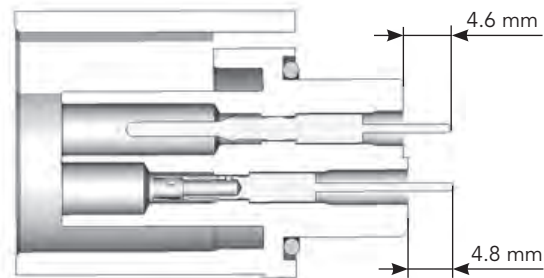

Note: The 6 pos. layout does not support PCB contacts

UTL SERIES

Technical information

■ Tooling	38
■ Crimping Instructions	40
■ Handle & Interchangeable Heads	42
■ Insertion Tool	43
■ Extraction Tool	43
■ Mated Connector Length	44
■ Assembly Instructions	45
■ Evaluation Kit 3 contacts + ground	49
■ Evaluation Kit 6 contacts	50
■ Evaluation Kit – Assembly Instructions	51
■ Rated Current & Working Voltage	52
■ UV Resistance	53
■ UL94 + UL1977	54
■ IEC 61984 & IP Codes Explained	57
■ IEC 61140 Explained	59
■ What is NEMA Rating ?	60
■ Ethernet for the Layman	61
■ RS-485 for the Layman	63

Automatic Crimping Tools



SOURIAU

Mecal is a leader in manufacturing tooling for crimping terminals over a stripped wire.

Established in 1976, Mecal has become one of the world's leading companies dedicated to the design and manufacture of semi automatic production tools for strip fed, open barrel crimp terminals, serving the Automotive, Telecom and Datacom industries.

SOURIAU designs, manufactures and markets **high performance - high reliability interconnect solutions** for severe environments dedicated to the Aerospace, Defense / Space, Heavy Industry (Railway & Mass Transit, Nuclear, Oil & Gas) and Industrial Equipment markets. SOURIAU has a worldwide presence with R & D centers and production sites in Europe, USA, Japan and India. The Company is deeply involved in the environmental protection with industrial sites following ISO 14001 and RoHS products. SOURIAU is now the Connection Technologies platform of Esterline Group.

SOURIAU has been working in partnership with Mecal for many years. With sales offices located in all major industrial regions of the world, the combined strengths of both organizations has resulted in a truly global solution to all your production tooling needs.



Mini Applicator

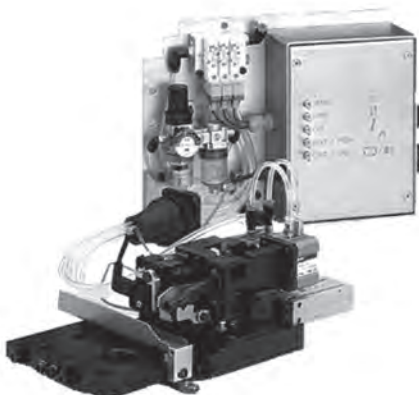

Stripper



Presses

Mecal sales network:

www.mecal.net/index.php/en/contacts

Tooling

Crimp Tool Table

Standard Contacts

Contact size	Part number	Head*	Handles*	Insertion tool	Extraction tools
#20 Ø 1mm	RM/RC 24W3K	S2ØRCM	SHANDLES	-	RX2ØD44
	RM/RC 20W3K				
	RM/RC 18W3K				
	SM 24WL3S*(1) SC 24WL3S*(1)	S2ØSCM2Ø			
	SM/SC 2ØWL3S*(1)				
#16 Ø 1.6mm	RM/RC 28M1*	S16RCM2Ø		RTM2Ø5	RX2Ø25GE1
	RM/RC 24M9*				
	RM/RC 2ØM13*				
	RM/RC 2ØM12*				
	RM/RC 16M23*	S16RCM16			
	RM/RC 14M3Ø*	S16RCM14			
	SM/SC 24ML1*	S16SCM2Ø			
	SM/SC 2ØML1*				
	SM/SC 16ML1*	S16SCML1			
	SM/SC 14ML1*				
SM/SC 16ML11*	S16SCML11				

(1) loose contact * endurance of SHANDLES & Head tools = 50,000 cycles

Specific Contacts



Contact size	Part number (1)	Hand tools* (SHANDLES) head	Tool with separate locator			Insertion tool	Extraction tool
			Hand tool	Positioner + locator setting			
#16 1.6 mm Sealed contact	RM/RC 16M25K	S16RCM1625	-	-	-	RTM2Ø5	RX2Ø25GE1
	RM/RC 14M25K	S16RCM1425	-	-	-		
#16 Ø 1.6mm Longer RM contact	RM28M1GE1K	S16RCM2Ø	-	-	-		
	RM24M9GE1K						
	RM2ØM13GE1K						
	RM16M23GE1K	S16RCM16					
RM14M3ØGE1K	S16RCM14						
#16 Ø 1.6mm Shorter RC contact	RC28M1GE7K	S16RCM2Ø	MH86Ø	MH86164G	4/6		
	RC24M9GE7K				5/6		
	RC2ØM13GE7K RC2ØM12GE7K				5/7		
	RC16M23GE7K	S16RCM16			6/8		
	RC14M3ØGE7K	S16RCM14			M317	UH25	3

(1) see page 30 for plating options and other contact details * endurance of SHANDLES & Head tools = 50,000 cycles

Coaxial contacts

See coax contacts details on page 33 and cabling notice pages 66 to 72.

Crimping instructions

Wire Stripping Length			
	Part number		Stripping length L (mm)
	Male	Female	
Machined contact 	#20 - Ø 1mm		
	RM24W3- / RM20W3- RM18W3-	RC24W3- / RC20W3- RC18W3-	4.8
	#16 - Ø 1.6mm		
	RM28M1- / RM24M9- RM20M13- / RM20M12-	RC28M1- / RC24M9- RC20M13- / RC20M12-	4.8
	RM16M23- / RM14M30-	RC16M23- / RC14M30-	7.1
Stamped & formed With insulation support 	#20 - Ø 1mm		
	SM24W3- / SM24WL3- SM20W3- / SM20WL3-	SC24W3- / SC24WL3- SC20W3- / SC20WL3-	4
	#16 - Ø 1.6mm		
	SM24M1- / SM24ML1- SM20M1- / SM20ML1-	SC24M1- / SC24ML1- SC20M1- / SC20ML1-	4
	SM16M11- / SM16ML11-	SC16M11- / SC16ML11-	4.65
	#16 - Ø 1.6mm		
	SM16M1- / SM16ML1-	SC16M1- / SC16ML1-	6.35
Without insulation support 	#16 - Ø 1.6mm		
	SM14M1- / SM14ML1-	SC14M1- / SC14ML1-	6.35

Note: See page 30 for plating options and other contact details

Crimping

One of the key factors which affects the performance of a connector is the way contacts are terminated. Crimped connections are nowadays seen as the best solution to ensure quality throughout the lifetime of the product. Here are some reasons why we recommend this method of termination for UTL connectors:

Advantages (Extract from the IEC 60352-2):

- Efficient processing of connections at each production level
- Processing by fully-automatic or semi- automatic crimping machines, or with hand operated tools
- No cold-soldered joints
- No degradation of the spring characteristic of female contacts by the soldering temperature
- No health risk from heavy metal and flux steam

- Preservation of conductor flexibility behind the crimped connection
- No burnt, discolored and overheated wire insulation
- Good connections with reproducible electrical and mechanical performances
- Easy production control.

To ensure that the crimp tooling is performing according to original specifications, it is important to carry out regular checks. A common way to check the performance of tooling is with a simple pull test, ideally using a dedicated electric pull tester. Minimum recommended pull forces are indicated in the tables below:

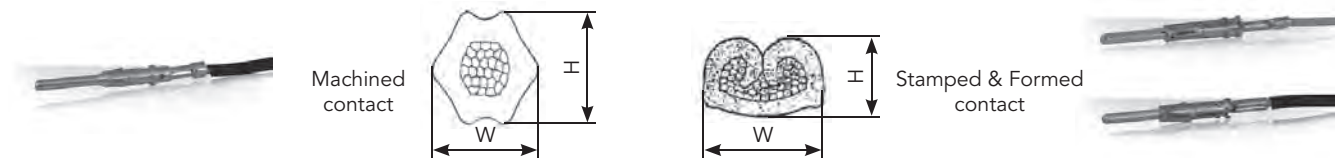

Active contact part	Contact type	Die location on heads	Wire section range	Section (mm ²)	Tensile straight test (mini)	Height (mm) H (±0.075)	Width (mm) W (±0.075)	Tooling head part number		
Machined contacts size #20 Ø 1 mm	RM24W3K RC24W3K	26/24	AWG 26	0.12 min	15 N	0.95	1.27	S20RCM		
			AWG 24	0.25 max	32 N					
	RM20W3K RC20W3K	22/20	AWG 22	0.32 min	40 N	1.26	1.78			
			AWG 20	0.50 max	60 N					
	RM18W3K RC18W3K	20/18	AWG 20	0.50 max	60 N	1.35	1.86			
			AWG 18	0.82 max	90 N					
S & F contacts size #20 Ø 1 mm	SM24WL3TK6* SC24WL3TK6*	26/24	AWG 26	0.12 min	15 N	0.80	1.49	S20SCM20		
			AWG 24	0.25 max	32 N					
	SM20WL3TK6* SC20WL3TK6*	22/20	AWG 22	0.32 min	40 N	1.01	1.53			
			AWG 20	0.50 max	60 N					
	Machined contacts size #16 Ø 1.6 mm	RM28M1K* RC28M1K*	30/28	AWG 30	0.05 min	11 N	1.14		1.41	S16RCM20
				AWG 28	0.08 max	11 N				
RM24M9K* RC24M9K*		26/24	AWG 26	0.12 min	15 N	1.15	1.41			
			AWG 24	0.25 max	32 N					
RM20M13K* RC20M13K*		22/20	AWG 22	0.32 min	40 N	1.26	1.76			
			AWG 20	0.50 max	60 N					
RM20M12K* RC20M12K*	22/20	AWG 22	0.32 min	40 N	1.26	1.76				
		AWG 20	0.50 max	60 N						
Machined contacts size #16 Ø 1.6 mm	RM16M23K* RC16M23K*	20	AWG 20	0.50 max	60 N	1.66	2.18	S16RCM16		
		18	AWG 18	0.82 max	90 N	1.80	2.28			
		16	AWG 16	1.50 max	150 N	1.96	2.43			
	RM14M30K* RC14M30K*	16	AWG 16	1.50 min	150 N	2.10	2.68	S16RCM14		
			14	AWG 14	2.50 min	230 N	2.30		2.78	
	S & F contacts size #16 Ø 1.6 mm	SM24ML1TK6* SC24ML1TK6*	26/24	AWG 26	0.12 min	15 N	0.84	1.50	S16SCM20	
AWG 24				0.25 max	32 N					
SM20ML1TK6* SC20ML1TK6*		22/20	AWG 22	0.32 min	40 N	1.02	1.54			
			AWG 20	0.50 max	60 N					
SM16ML11TK6* SC16ML11TK6*		18	AWG 18	0.82 min	90 N	1.32	2.09	S16SCML11		
			16	AWG 16	1.50 max	150 N	1.36		2.10	
SM16ML1TK6* SC16ML1TK6*		18	AWG 18	0.82 min	90 N	1.49	2.02	S16SCML1		
			16	AWG 16	1.50 max	150 N	1.7		2.05	
SM14ML1TK6* SC14ML1TK6*		14	AWG 14	2.50 max	230 N	1.79	2.58			

*: example of plating, for other plating see page 30

Handle & Interchangeable Heads

User Guide

1) Fully close then release the tool, keep it open.
Open the 2 pins.



2) Choose the adapter head (sold separately), keep vertical and slide it into the handle until the mechanical end.



3) Close the two pins simultaneously to maintain the head.



4) Strip the cable properly check the recommended size in the catalog on page 40.

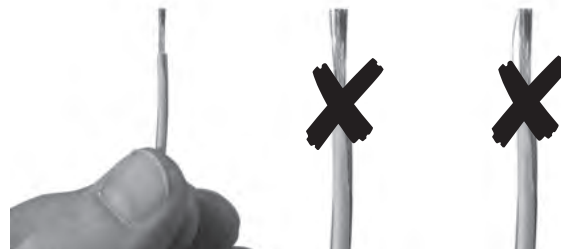

5) Place conductors, with no deteriorations, in the bucket contact. All strands to be located in the crimp bucket.



6) Position the contact in the bottom of the tool by checking its orientation.



7) To crimp contact assembly-cable, tighten sharply the clip to the end of the mechanism (max 175N).



8) To control crimp quality, slightly pull cable with two fingers to control retention.



Insertion Tool

Contact size	Part Number
#16	RTM205



RTM205

Extraction Tool

Contact size	Part Number
#20	RX20D44
#16	RX2025GE1



Contact Extraction Instructions

Place the tool into the cavity from front face of the connector, push on the handle, then remove the contact.



Mated Connector Length

UTL0 + UTL6

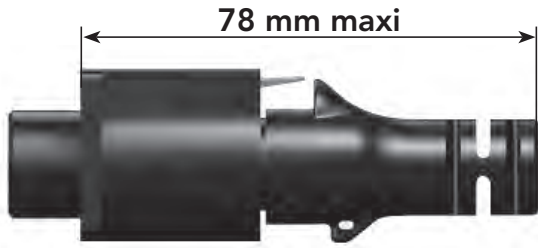

UTL7 + UTL6

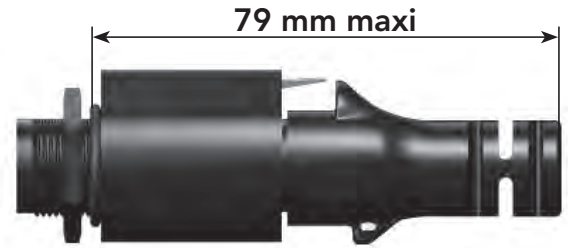

UTL1 + UTL6

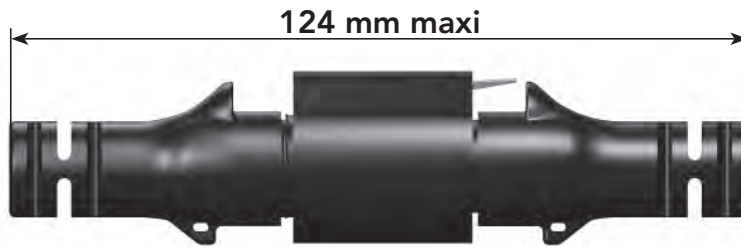

Plug Cable Assembly

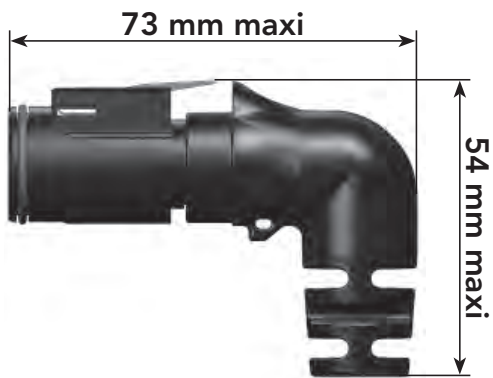

In Line Cable Assembly

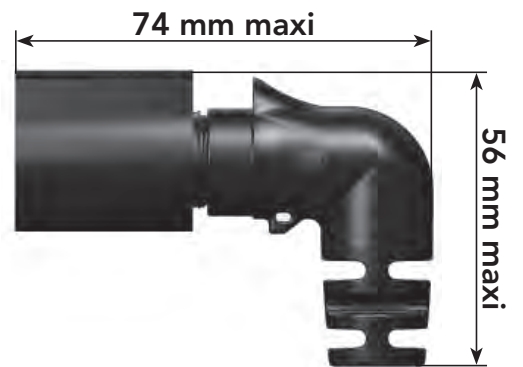

Note: all dimensions are in mm

Assembly Instructions

Stripping Dimensions

- Female insulator: Strip external cable sheath, adjust ground cable length
- Male insulator: Strip external cable sheath, adjust signal cable lengths
- Crimp contacts
- Place the lubricant on the holes until the chamfer end only for machined sealed contacts
- Place all the contacts inside the corresponding cavities at the same time
- Manually push each contact, or use specific tool (**RTM205**), until audible click.
Check each contact retention, with two fingers retraction.

3 + ground

UTL0103G1P - UTL6103G1P -
UTL7103G1P - UTL1103G1P

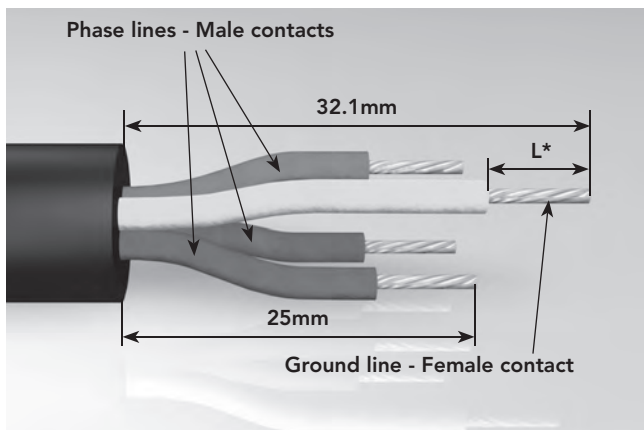

UTL0103G1S - UTL6103G1S -
UTL7103G1S - UTL1103G1S

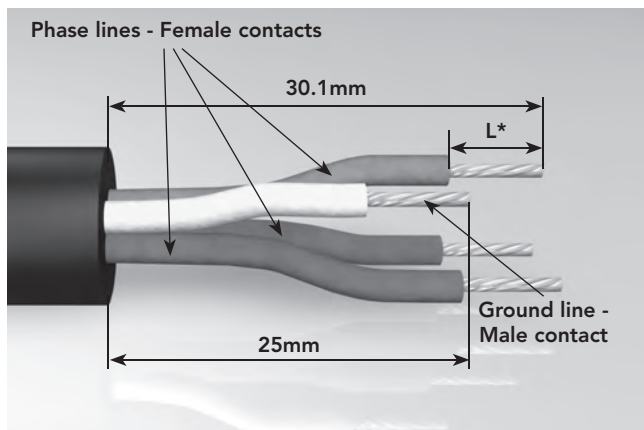

* see page 40

6 pos.

UTL6102G1W3P - UTL7102G1W3P -
UTL1102G1W3P

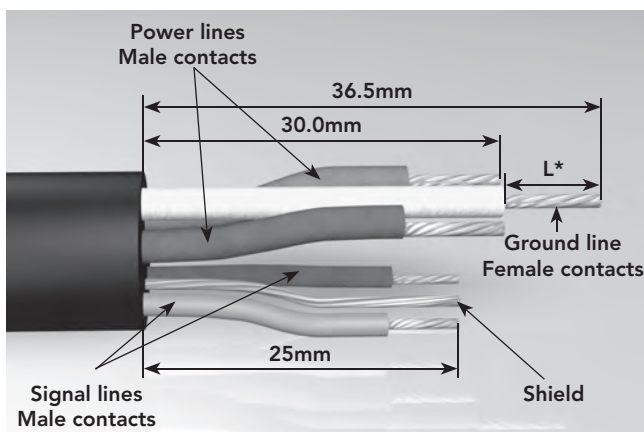

UTL6102G1W3S - UTL7102G1W3S -
UTL1102G1W3S

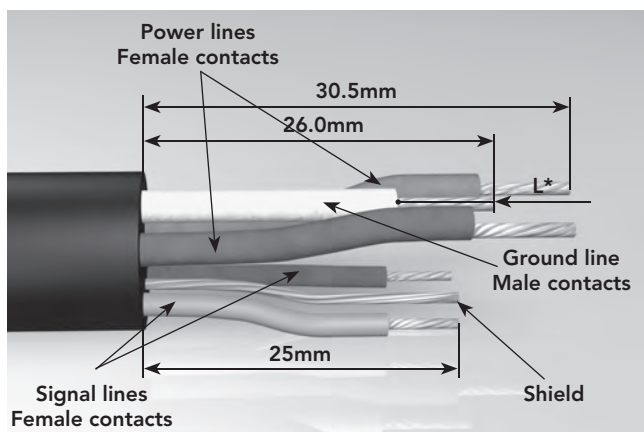

* see page 40

Ground contact must be different compared to the others.

Assembly Instructions (Continued)

UTL0 Assembly (Mounting Suggestion)

- Strip wires, crimp contacts (see pages 40 - 41)
- Insert contacts into connector cavities (insert manually or use tool **RTM205** crimp contacts)
- Place receptacle in the panel cut-out (see dimension page 19 for UTL103G1 or page 23 for UTL102G1W3)
- Secure receptacle with M3 screws (not supplied), torque 0.7 N.m maxi

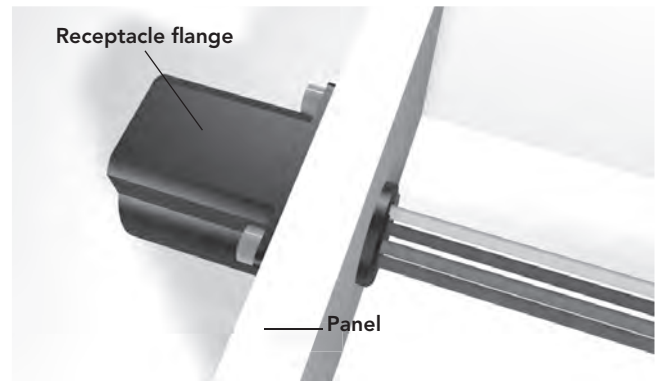
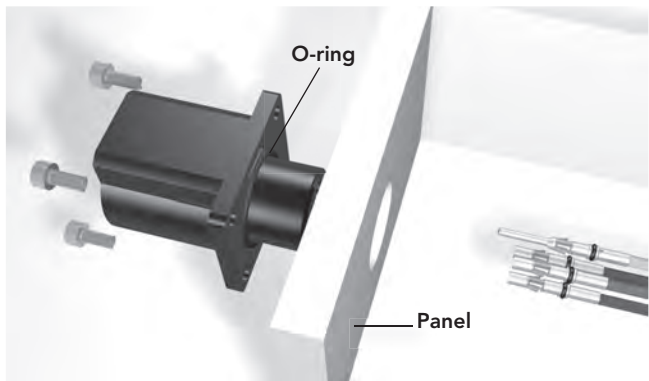

UTL6 or UTL1 Assembly

- Strip external cable jacket (see page 45)
- Strip wires, crimp contacts (see pages 40 - 41)
- Insert contacts into connector cavities (insert manually or use tool **RTM205** crimp contacts)
- Do an overmolding on the wired set

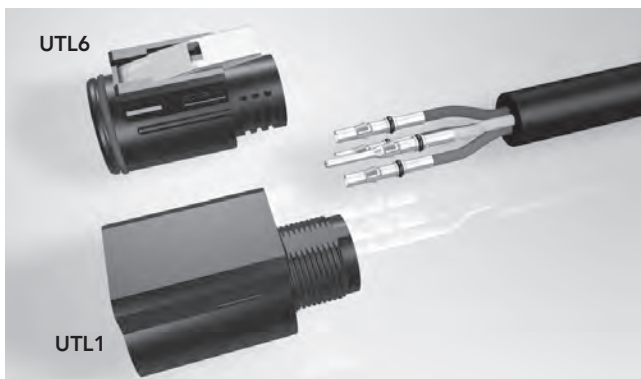

UTL7 Assembly (Mounting Suggestion)

- Slide nut over the wires
- Strip wires, crimp contacts (see pages 40 - 41)
- Insert contacts into connector cavities (insert manually or use specific tool **RTM205** crimp contacts)
- Seat o-ring, place receptacle in the panel cut-out (see dimension page 19 for UTL103G1 or page 23 for UTL102G1W3)
- Tighten jam nut torque: 2.5 Nm maxi, tightening tool: 7/8"

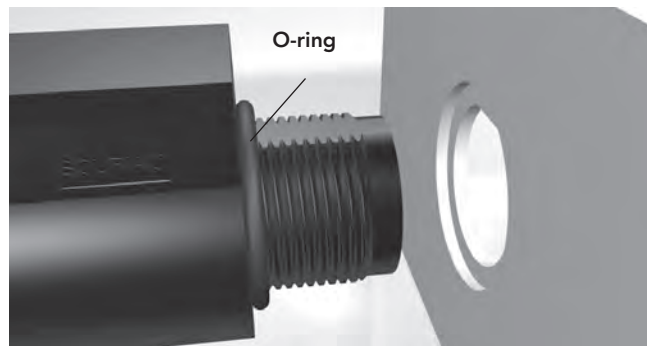
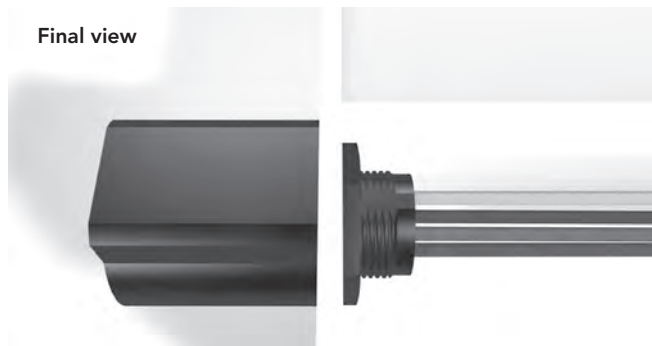
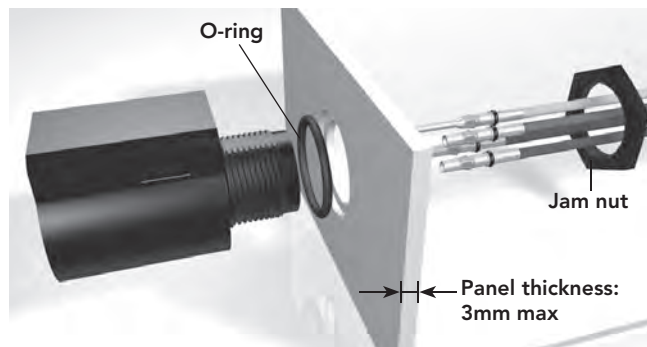

Assembly Instructions (Continued)

SWSFILLERPLUG Mounting for 3 + Ground

Push the sealing plug into each connector cavity to seal until a mechanical stop.

UTL0

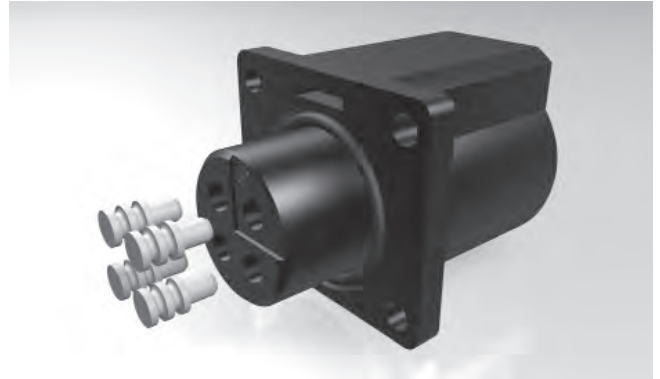
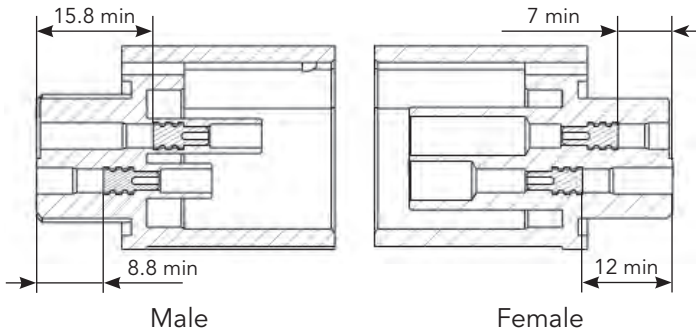

UTL7 & UTL1

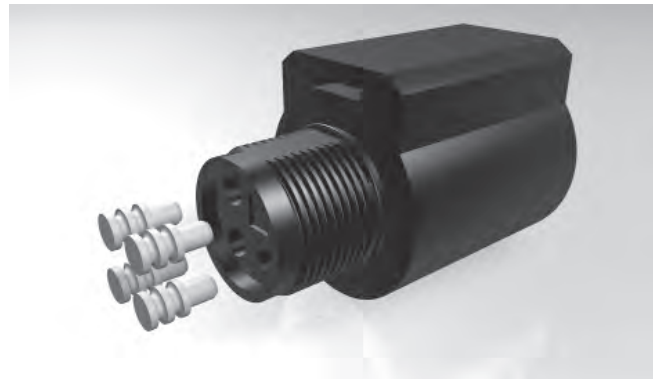
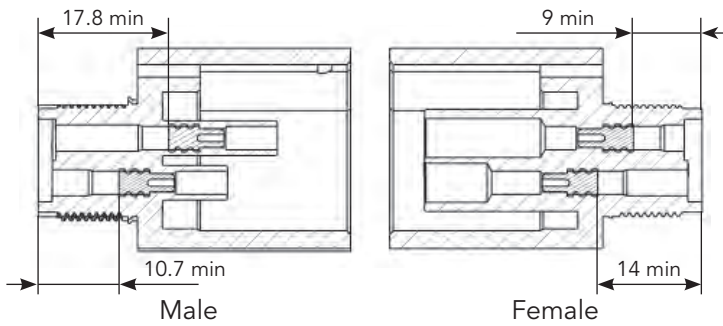

UTL6

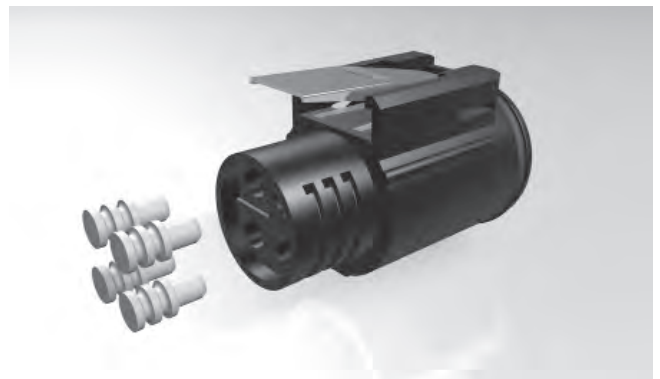
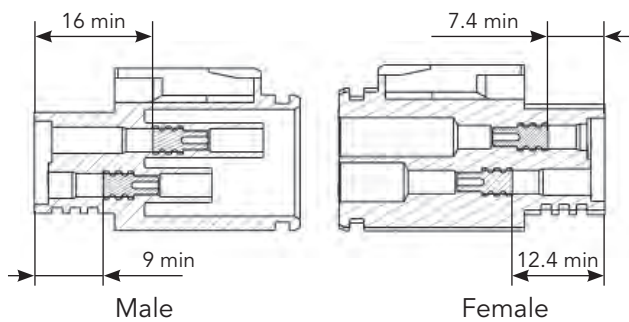

Note: all dimensions are in mm

Evaluation Kit 3 Contacts + Ground Part Number (103G1)

Male insert

Connector type	Wire section		Part number	Kit contains
Plug	AWG20	0.5 mm ²	UTL6103G1P20AWG	4 x #16 male contacts: SM20ML1S31 + 2 x #16 female contacts: SC20ML1S31 + 1 x boot
	AWG16	1.5 mm ²	UTL6103G1P16AWG	4 x #16 male contacts: SM16ML1S31 + 2 x #16 female contacts: SC16ML1S31 + 1 x boot
	AWG14	2.5 mm ²	UTL6103G1P14AWG	4 x #16 male contacts: SM14ML1S31 + 2 x #16 female contacts: SC14ML1S31 + 1 x boot
In line receptacle	AWG20	0.5 mm ²	UTL1103G1P20AWG	4 x #16 male contacts: SM20ML1S31 + 2 x #16 female contacts: SC20ML1S31 + 1 x boot
	AWG16	1.5 mm ²	UTL1103G1P16AWG	4 x #16 male contacts: SM16ML1S31 + 2 x #16 female contacts: SC16ML1S31 + 1 x boot
	AWG14	2.5 mm ²	UTL1103G1P14AWG	4 x #16 male contacts: SM14ML1S31 + 2 x #16 female contacts: SC14ML1S31 + 1 x boot
Jam nut receptacle	AWG20	0.5 mm ²	UTL7103G1P20AWG	4 x #16 male contacts: SM20ML1S31 + 2 x #16 female contacts: SC20ML1S31
	AWG16	1.5 mm ²	UTL7103G1P16AWG	4 x #16 male contacts: SM16ML1S31 + 2 x #16 female contacts: SC16ML1S31
	AWG14	2.5 mm ²	UTL7103G1P14AWG	4 x #16 male contacts: SM14ML1S31 + 2 x #16 female contacts: SC14ML1S31
Square flange receptacle	AWG20	0.5 mm ²	UTL0103G1P20AWG	4 x #16 male contacts: SM20ML1S31 + 2 x #16 female contacts: SC20ML1S31
	AWG16	1.5 mm ²	UTL0103G1P16AWG	4 x #16 male contacts: SM16ML1S31 + 2 x #16 female contacts: SC16ML1S31
	AWG14	2.5 mm ²	UTL0103G1P14AWG	4 x #16 male contacts: SM14ML1S31 + 2 x #16 female contacts: SC14ML1S31

Female insert

Connector type	Wire section		Part number	Kit contains
Plug	AWG20	0.5 mm ²	UTL6103G1S20AWG	2 x #16 male contacts: SM20ML1S31 + 4 x #16 female contacts: SC20ML1S31 + 1 x boot
	AWG16	1.5 mm ²	UTL6103G1S16AWG	2 x #16 male contacts: SM16ML1S31 + 4 x #16 female contacts: SC16ML1S31 + 1 x boot
	AWG14	2.5 mm ²	UTL6103G1S14AWG	2 x #16 male contacts: SM14ML1S31 + 4 x #16 female contacts: SC14ML1S31 + 1 x boot
In line receptacle	AWG20	0.5 mm ²	UTL1103G1S20AWG	2 x #16 male contacts: SM20ML1S31 + 4 x #16 female contacts: SC20ML1S31 + 1 x boot
	AWG16	1.5 mm ²	UTL1103G1S16AWG	2 x #16 male contacts: SM16ML1S31 + 4 x #16 female contacts: SC16ML1S31 + 1 x boot
	AWG14	2.5 mm ²	UTL1103G1S14AWG	2 x #16 male contacts: SM14ML1S31 + 4 x #16 female contacts: SC14ML1S31 + 1 x boot
Jam nut receptacle	AWG20	0.5 mm ²	UTL7103G1S20AWG	2 x #16 male contacts: SM20ML1S31 + 4 x #16 female contacts: SC20ML1S31
	AWG16	1.5 mm ²	UTL7103G1S16AWG	2 x #16 male contacts: SM16ML1S31 + 4 x #16 female contacts: SC16ML1S31
	AWG14	2.5 mm ²	UTL7103G1S14AWG	2 x #16 male contacts: SM14ML1S31 + 4 x #16 female contacts: SC14ML1S31
Square flange receptacle	AWG20	0.5 mm ²	UTL0103G1S20AWG	2 x #16 male contacts: SM20ML1S31 + 4 x #16 female contacts: SC20ML1S31
	AWG16	1.5 mm ²	UTL0103G1S16AWG	2 x #16 male contacts: SM16ML1S31 + 4 x #16 female contacts: SC16ML1S31
	AWG14	2.5 mm ²	UTL0103G1S14AWG	2 x #16 male contacts: SM14ML1S31 + 4 x #16 female contacts: SC14ML1S31

Evaluation Kit 6 Contacts Part Number (102G1W3)

Male insert

Connector type	Wire section		Part number	Kit contains
Plug	AWG16	1.5 mm ²	UTL6102G1W3P16AWG	3 x #16 male contacts: SM16ML1S31 + 2 x #16 female contacts: SC16ML1S31 + 1 x #20 male contact: SM20W3S26 + 3 x #20 male contacts : SM24W3S26 + 1 x boot
	AWG14	2.5 mm ²	UTL6102G1W3P14AWG	3 x #16 male contacts: SM14ML1S31 + 2 x #16 female contacts: SC14ML1S31 + 1 x #20 male contact: SM20W3S26 + 3 x #20 male contacts : SM24W3S26 + 1 x boot
In line receptacle	AWG16	1.5 mm ²	UTL1102G1W3P16AWG	3 x #16 male contacts: SM16ML1S31 + 2 x #16 female contacts: SC16ML1S31 + 1 x #20 male contact: SM20W3S26 + 3 x #20 male contacts : SM24W3S26 + 1 x boot
	AWG14	2.5 mm ²	UTL1102G1W3P14AWG	3 x #16 male contacts: SM14ML1S31 + 2 x #16 female contacts: SC14ML1S31 + 1 x #20 male contact: SM20W3S26 + 3 x #20 male contacts : SM24W3S26 + 1 x boot
Jam nut receptacle	AWG16	1.5 mm ²	UTL7102G1W3P16AWG	3 x #16 male contacts: SM16ML1S31 + 2 x #16 female contacts: SC16ML1S31 + 1 x #20 male contact: SM20W3S26 + 1 x #20 male contacts : SM24W3S26
	AWG14	2.5 mm ²	UTL7102G1W3P14AWG	3 x #16 male contacts: SM14ML1S31 + 2 x #16 female contacts: SC14ML1S31 + 1 x #20 male contact: SM20W3S26 + 3 x #20 male contacts : SM24W3S26

Female insert

Connector type	Wire section		Part number	Kit contains
Plug	AWG16	1.5 mm ²	UTL6102G1W3S16AWG	2 x #16 male contacts: SM16ML1S31 + 3 x #16 female contacts: SC16ML1S31 + 1 x #20 male contact: SC20W3S25 + 3 x #20 male contacts : SC24W3S25 + 1 x boot
	AWG14	2.5 mm ²	UTL6102G1W3S14AWG	2 x #16 male contacts: SM14ML1S31 + 3 x #16 female contacts: SC14ML1S31 + 1 x #20 male contact: SC20W3S25 + 3 x #20 male contacts : SC24W3S25 + 1 x boot
In line receptacle	AWG16	1.5 mm ²	UTL1102G1W3S16AWG	2 x #16 male contacts: SM16ML1S31 + 3 x #16 female contacts: SC16ML1S31 + 1 x #20 male contact: SC20W3S25 + 3 x #20 male contacts : SC24W3S25 + 1 x boot
	AWG14	2.5 mm ²	UTL1102G1W3S14AWG	2 x #16 male contacts: SM14ML1S31 + 3 x #16 female contacts: SC14ML1S31 + 1 x #20 male contact: SC20W3S25 + 3 x #20 male contacts : SC24W3S25 + 1 x boot
Jam nut receptacle	AWG16	1.5 mm ²	UTL7102G1W3S16AWG	2 x #16 male contacts: SM16ML1S31 + 3 x #16 female contacts: SC16ML1S31 + 1 x #20 male contact: SC20W3S25 + 1 x #20 male contacts : SC24W3S25
	AWG14	2.5 mm ²	UTL7102G1W3S14AWG	2 x #16 male contacts: SM14ML1S31 + 3 x #16 female contacts: SC14ML1S31 + 1 x #20 male contact: SC20W3S25 + 3 x #20 male contacts : SC24W3S25

Evaluation Kit – Assembly Instructions

The boot is semi-flexible and heat-shrinkable with a moldable adhesive inner lining.

- Place the heat shrink boot over the cable
- Strip the cable jacket (see page 45)
- Strip the individual wires (see page 40)
- Crimp the contacts (see page 41) **ò**
- Place the contacts in their cavities, checking the retention by slightly pulling the cable **ù**
- Clean the connector surface and the cable jacket with isopropyl alcohol
(Note: It is advised to rub the jacket with sand paper and clean the jacket before shrinking the boot)
- Position the boot over the rear threads **ä**
- Heat the boot with a heat gun: minimum shrink temp: 80°C - minimum full recovery temp: 110°C make sure to apply the heat evenly around the boot. Starting by applying the heat from the rear of the connector. **ë**
Do not apply excessive heat, as it will damage the connector and/or boot.
- Let the boot cool down **ö**
- Check for good retention and the boot glue grip **ü**.

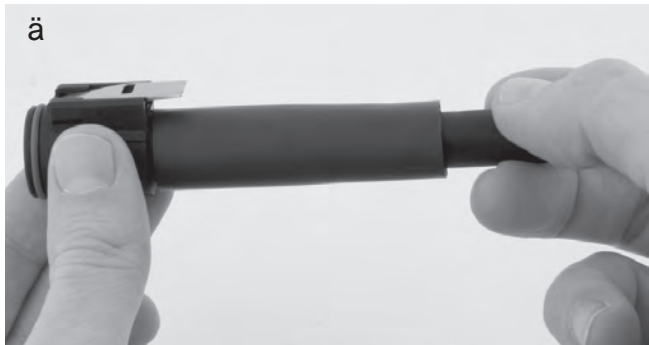
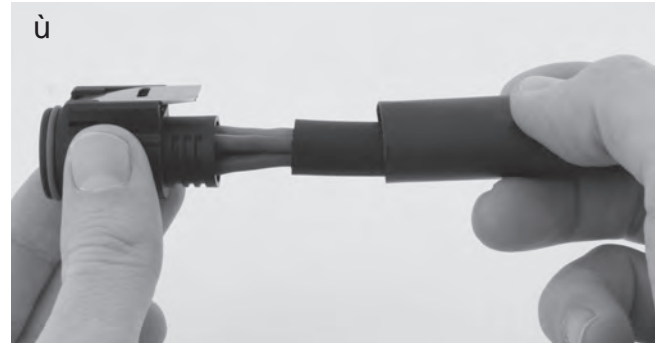
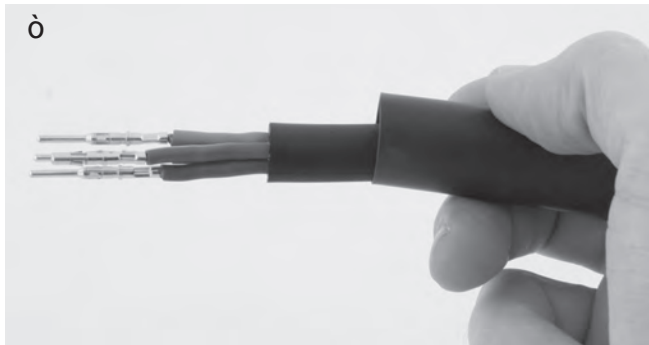

Rated Current & Working Voltage

Current Carrying Capacity

The current carrying capacity of a connector is limited by the thermal properties of materials used in its construction. The amount of current that can be handled depends on the size of cable used, the ambient temperature and the heat that is generated inside the connector. Part 3 of the IEC 60512 standard determines through a derating curve, the maximum current permissible, which varies from one layout to another (Fig.1 & Fig.2). Wire size plays an important role as well, since they help to dissipate heat and avoid overheating (Fig.1 & Fig.3).

Please note that the curve should be adjusted when dealing with potential hot spots, which can occur as a result of unequal loading of current across a number of contacts. As a general rule, it is best to avoid locating power handling contacts in the middle of the connector; try to locate them towards the edge where heat can be dissipated more effectively. Eventually you should find a level which represents the permissible operating range:

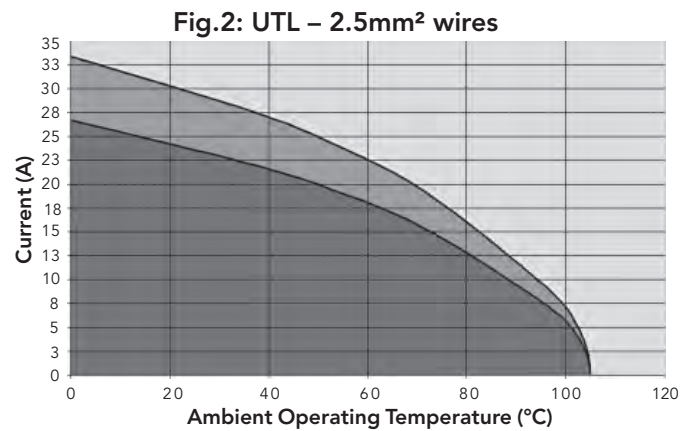
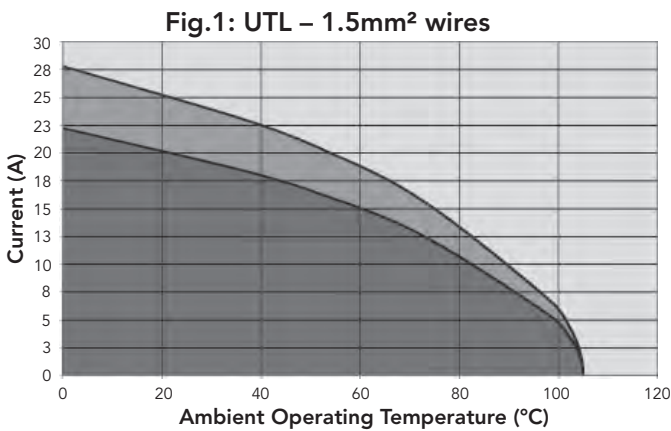

Current use
 Limited use
 Not recommended use

The **rated current** is defined as uninterrupted continuous current that a connector can take when all contacts are energized simultaneously without exceeding the maximum limit of temperature. The ground contact is never loaded.

UV Resistance

UV Resistance

Solar radiation affects all materials, but plastics can be susceptible to extreme degradation over time. The choice of materials for the UTL series was therefore a critical consideration.

All over the world we are not exposed to the same amount of energy given by the sun. The chart shown here clearly illustrates this.

So we performed test according to the ISO 4892-2 and simulated 5 years exposure to outdoor environments (temperature, humidity, etc...)

After this period there was no significant colour variation, no crazing, no cracking and no major variation of mechanical properties.

In addition to that we asked UL to perform UV test per the UL756C. Our material has been rated F1 which is the highest level in this standard.

Yearly mean of daily irradiation in UV (280-400 nm) on horizontal plane (J/cm²) (1990-2004)

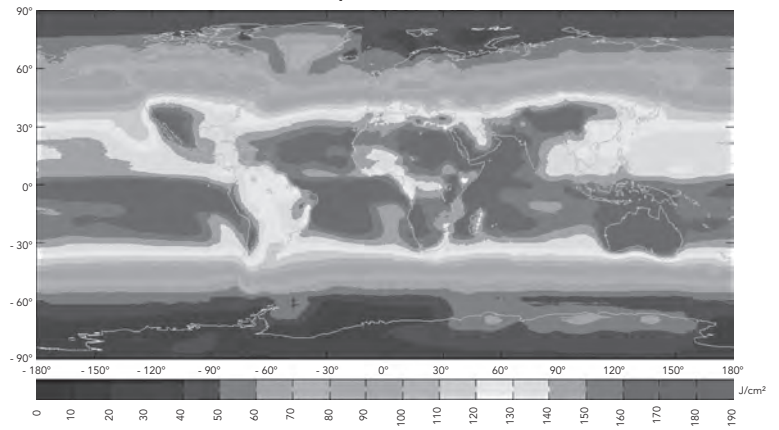

UL94 + UL1977



There are two main standards for industrial connectors: UL94 & UL1977

UL 94: Tests for Flammability of Plastic Materials for Parts in Devices and Appliances

This standard is dedicated to plastics flammability. It characterizes how the material burns in various orientation and thicknesses. Whereas most of our competitor are using a 50W test to classify the ability of their solution to withstand fire, SOURIAU decided to increase this to a 500W test. New regulations tend to emphasize the importance of burning behavior making the 50W test less and less relevant.

The UTL series has been rated at 5VA.

Procedure: Bar specimens are to be 125^{±5} mm long by 13^{±0.5} mm wide, and provided in the minimum thickness.

Plaque specimens are to be 150^{±5} mm by 150^{±5} mm and provided in the minimum thickness.

Thicker specimens may also be provided and shall be tested if the results obtained on the minimum thickness indicate inconsistent test results. The maximum thickness is not to exceed 13 mm.

Conditions	5VA
Afterflame time plus afterglow time after fifth flame application for each individual bar specimen	≤60s
Cotton indicator ignited by flaming particles or drops from any bar specimen	No
Burn-through (hole) of any plaque specimen	No

5VA Vertical burning:

- The specimen is clamped from the upper 6 mm of the specimen, with the longitudinal axis vertical, so that the lower end of the specimen is 300^{±10} mm above a horizontal layer of not more than 0.08 g of absorbent cotton thinned to approximately 50 x 50 mm and a maximum thickness of 6 mm.
- The 500W flame is then to be applied to one of the lower corners of the specimen so that the tip of the blue cone is within 0 to 3 mm of the specimen edge.
- Apply the flame for 5^{±0.5} seconds and then remove for 5^{±0.5} seconds. Repeat the operation until the specimen has been subjected to five applications of the test flame.

5VA Horizontal burning:

- Support the plaque specimen by a clamp in the horizontal plane.
- The flame is then to be applied to the centre of the bottom surface of the plaque so that the tip of the blue cone is within 0 to 3 mm of the plaque surface.
- Apply the flame for 5^{±0.5} seconds and then remove for 5^{±0.5} seconds. Repeat the operation until the plaque specimen has been subjected to five applications of the test flame.
- After the fifth application of the test flame, and after all flaming or glowing combustion has ceased, it is to be observed whether or not the flame penetrated (burned through) the plaque material. In addition, no opening greater than 3 mm shall appear after the test.

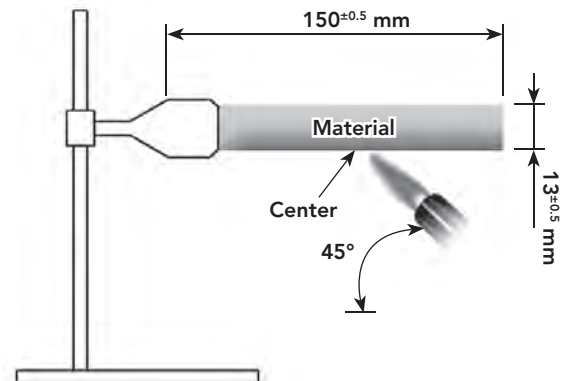
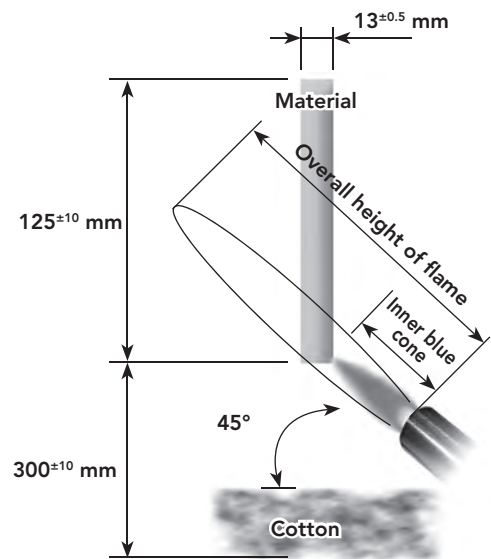

UL1977

There are several standards which deal with plug and receptacle. Each of them is only for a small area of applications. It could be telecommunication, etc. The UL 1977 covers single and multipole connectors intended for factory assembly.

Requirements apply to devices taking into account intensity and voltage. The categories are as follows:

	0	30 V (42 V peak)	600 V
0	Type 0		Type 1A
8.3 A	Type 1B		Type 2
31 A			Type 3
200 A	Type 4		
1000 A			

According to above table, the level of performance that has to be reached could be different. Most of them are explained in the following page.

Insulating Materials:

Material uses for electrical insulation, as a minimum, have to comply with the characteristics shown below:

• **Minimum ratings for polymeric materials**

Type	Flame rating	Relative thermal index (RTI) Electrical/mechanical w/o impact */**
0	-	50/50
1A	HB	50/50
1B	HB	50/50
2	HB	50/50
3	HB	50/50
4	HB	50/50

* The RTI of the material shall not be lower than the temperature measured during the Temperature Test.

** For a thickness less than that for which a value has been established, the RTI of the minimum thickness with an established value shall be used.

Assembly:

Connector has to be keyed to prevent any mismatching that can damage the machine or hurt the user. In the same way, plugs and sockets have to be equipped to protect persons against contact with live parts.

Finally the identified grounding contact shall be located so that the corresponding electrical continuity has to be completed before any other contact.

UL94 + UL1977 (Continued)



UL1977

Spacing:

For a 250V max connector, distance through air or over material shall be 1.2mm whereas from 250V to 600V connector the spacing is 3.2mm minimum. These distances have to be taken between uninsulated live parts as shown in the matrix below:

• **Applicability of spacing requirements**

Type	Uninsulated live part - uninsulated live part of opposite polarity	Uninsulated live part - uninsulated grounded metal part	Uninsulated live part - exposed dead metal part
0	No	No	No
1A	Yes	Yes	Yes
1B	Yes	Yes	No
2	Yes	Yes	Yes
3	Yes	Yes	Yes
4	Yes	Yes	Yes

An alternative way to determine voltage rating is with the Dielectric-Withstand test. If during one minute there is no arc-over or breakdown the rated voltage is given as shown below:

- a) 500 volts for a type 1B device
- b) 1000 volts plus twice rated voltage for types 1A, 2, 3 and 4 devices.

Marking:

A device shall be legibly marked with the manufacturer's trade name, trade mark, or other descriptive marking by which the organization responsible for the product may be identified. (Exception: If the device is too small, or where the legibility would be difficult to attain, the manufacturer's name, trademark, or other descriptive marking may appear on the smallest unit container or carton)

The following shall be marked on the device or on the smallest unit container or carton or on a stuffer sheet in the smallest unit container or carton:

- a) The catalog number or an equivalent designation
- b) The electrical rating in both volts and amperes, if assigned
- c) Whether ac or dc, if restricted
- d) Flammability class, if identified

Example : 10A 500V UL94 V-0

IEC 61984 & IP Codes Explained

IEC 61984

The norm is dedicated to connectors with rated voltage above 50V and up to 1000V and rated currents up to 125A per contact. Depending on your application connectors should be compliant with another standard. This has to be double checked with the customer.

There are a lot of constructional requirements and performances specified in that standard. Most of them are illustrated in greater details hereafter.

Provisions for Earthing:

The UTL connector is intended to be used on Class I, II and III systems (See IEC 61140) . Not like any other connector the UTL could be used to interrupt current. The "First mate Last break" contact feature is built in so any regular contact will ensure the functionality. Critically, among all of the normal assumptions we make in designing a connector, this contact has to be considered as a live part and must be protected against electric shock by double or reinforced insulation.

IP Code:

IP is a coding system defined by the IEC 60529 to indicate the degrees of protection provided by an enclosure. The aim of this is to give information regarding the accessibility of live parts against ingress of water and other foreign bodies.

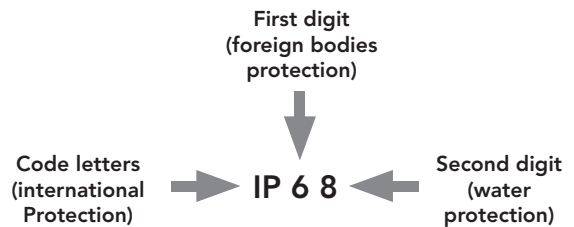

1 st digit	Degree of protection	2 nd digit	Degree of protection
0	No protection against accidental contact. No protection against solid foreign bodies.	0	No protection against water.
1	Protection against contact with any large area by hand and against large solid foreign bodies with a diameter bigger than 50 mm.	1	Drip-proof. Protection against vertical water drips.
2	Protection against contact with the fingers. Protection against solid foreign bodies with a diameter bigger than 12 mm.	2	Drip-proof. Protection against water drips up to a 15° angle.
3	Protection against tools, wires or similar objects with a diameter bigger than 2.5 mm. Protection against small solid bodies with a diameter bigger than 2.5 mm.	3	Spray-proof. Protection against diagonal water drips up to a 60° angle.
4	Same as 3 however diameter is bigger than 1 mm.	4	Splash-proof. Protection against splashed water from all directions.
5	Full protection against contact. Protection against interior injurious dust deposits.	5	Hose-proof. Protection against water (out of a nozzle) from all directions.
6	Total protection against contact. Protection against penetration of dust.	6	Protection against temporary flooding.
		7	Protection against temporary immersions.
		8	Protection against water pressure. Pressure to be specified by supplier.

UTL offers high sealing performance IP68 / 69K...
Even in dynamic situations.

In addition to the IEC 60529 we conjointly use the DIN 40050 part 9 which are dedicated to road vehicles. The main differences are:

- **First digit:** 5 replaced by 5K, 6 by 6K. In the DIN the tested equipment is not depressurized as it is in the IEC.
- **Second digit:** 5K and 6K has been added and are equivalent respectively to 5 and 6 but with higher pressure. 9K which represents the High pressure cleaning.

9K	High pressure hose-proof. Protection against high pressure water (out of a nozzle) from all directions.
----	--

IEC 61984 & IP Codes Explained (Continued)

IEC 61984

Overvoltage

UTL connectors are qualified to be used on systems rated at Overvoltage category III

Per the IEC 60664-1 (formerly VDE 0110) each category is linked to the end application and where the device will be implemented:

- **Category IV** (primary overcurrent protection equipment):
Origin of the installation
- **Category III** (Any fixed installation with a permanent connection)
Fixed installation and equipment and for cases where the reliability and the availability is subject to special requirements
- **Category II** (Domestic appliances):
Energy consuming equipment to be supplied from the fixed installation
- **Category I** (Protected electronic circuit):
For connection to circuit in which measures are taken to limit transient overvoltage.

Pollution degree

Per the IEC 60664-1 (formerly VDE 0110) the environment affects the performance of the insulation. Particles can build a bridge between two metal parts. As a rule dust mixed with water can be conductive and more generally speaking metal dust is conductive. Finally, the standard defines 4 levels of pollution:

- **Degree 1** (Air conditioned dry room):
No pollution or only dry, non conductive pollution occurs. The pollution has no influence.
- **Degree 2** (Personal computer in a residential area):
Only non conductive pollution occurs except that occasionally a temporary conductivity caused by condensation is to be expected.
- **Degree 3** (Machine tools):
Conductive pollution occurs or dry non-conductive pollution occurs which becomes conductive due to condensation which is to be expected.
- **Degree 4** (Equipments on roof, locomotives):
Continuous conductivity occurs due to conductive dust, rain or other wet conditions.

Finally, the harsher the environment is, the longer clearance and creepage distances should be. Nonetheless, according the IEC 61984, enclosure rated at IP54 or higher can be dimensioned for a lower pollution degree. This applies to mated connectors disengaged for test and maintenance.

Marking

The marking should give enough details to the user to know what the main characteristics are and without going deep in technical documentation. Below examples identify the suitability of the connector:

- **Example 1:**
Marking of a connector with rated current 16A, rated voltage 400V, rated impulse voltage 6kV and pollution degree 3, 2 and 1 for use in any system, preferably unearthed or delta-earthed systems:

16A 400V 6kV 3

- **Example 2:**
Marking of a connector with rated current 16A, rated insulation voltages line-to-earth 250V, line-to-line 400V, rated impulse voltage 4kV and pollution degree 3, 2 and 1 for use in earthed systems:

16A 250V 400V 4kV 3

IEC 61140 Explained

IEC 61140

On a daily basis, we are using many electrical appliances, some are grounded, and some are not. The levels of grounding protection are clearly defined by the International Electrotechnical Commission standard IEC 61140, a standard that has an influence on our connectors and how they should be used; our customers therefore need to pay particular attention to the three categories defined within this standard to ensure compatibility with their system. Everything explained hereafter is valid for connectors not intended to interrupt current.

Class I:

Devices which belong to this category have their chassis grounded via the ground wire (green/yellow in Europe, green in the US, Canada and Japan). A fault in the appliance might cause a live conductor to energize the casing. In this case, the current flows to the ground conductor and the circuit interrupter will cut off the power supply. In case of the UTL series, the envelope cannot become live since it is made in plastic. There is no special care to be taken to attach the connector shell to the ground.

Class II:

Products in this category have reinforced insulation, meaning that the casing does not need to be connected to ground. In this case, the possibility of electric shock has been removed. Most of the time, reinforced insulation means double insulation, i.e. the second layer will take over the first one in case the first one fails. The UTL series could be used in that condition. We recommend to contact SOURIAU for further explanation.

Note: UL 1310 also defines a class II device, but in that case this is just to set the upper limit of use, like a wall charger for our cell phone.

Class III:

In this category, electrical appliances are fed by a low voltage source (<48VAC or < 120VDC). In normal conditions live conductors can be accessible without any risk for the end user. No particular attention needs to be taken in regards to UTL series when it comes to a class III device.

Conclusion :

UTL series can be used in class I and class III environments, but each category affects the product performance. Throughout the catalog, current and voltage ratings have been given for class I devices keeping in mind the ground conductor needs to be attached according to recommended wiring instructions.

Note: Special applications like recreational vehicles are not under the scope of the IEC 61140.

What is NEMA Rating ?

- NEMA ratings vs IP ratings

Whereas IP ratings only consider protection against ingress of foreign bodies (first digit) and ingress of water (second digit), NEMA ratings consider these but also verify protection from external ice, corrosive materials, oil immersion, etc.

The correlation between NEMA & IP being limited only to dust and water, we can state that a NEMA type is equivalent to an IP rating but it is not possible to say the contrary.

Below a list of some NEMA standards:

Enclosure rating	IP20	IP22	IP55	IP64	IP65	IP66	IP67
Type 1	•						
Type 3				•			
Type 3R		•					
Type 3S				•			
Type 4						•	
Type 4X						•	
Type 6							•
Type 12			•				
Type 13					•		

- indicates compliance



Type 6 rating can be either Type 6 or Type 6P - please see below:

6	IP67	Enclosures constructed for either indoor or outdoor use to provide a degree of protection to personnel against incidental contact with the enclosed equipment, falling dirt, hose-directed water, the entry of water during occasional temporary submersion at a limited depth and damage from external ice formation.
6P	IP67	Enclosures constructed for either indoor or outdoor use to provide a degree of protection to personnel against incidental contact with the enclosed equipment, falling dirt, hose-directed water, the entry of water during prolonged submersion at a limited depth and damage from external ice formation.

Ethernet for the Layman

In order to explain basic Ethernet theory, we can use a functional comparison to a busy city with highways, buildings and cars. To illustrate this, the table below provides correlation between the different components/pieces/links that encompass Ethernet network connectivity, and the larger scale infrastructure of a metropolitan city.

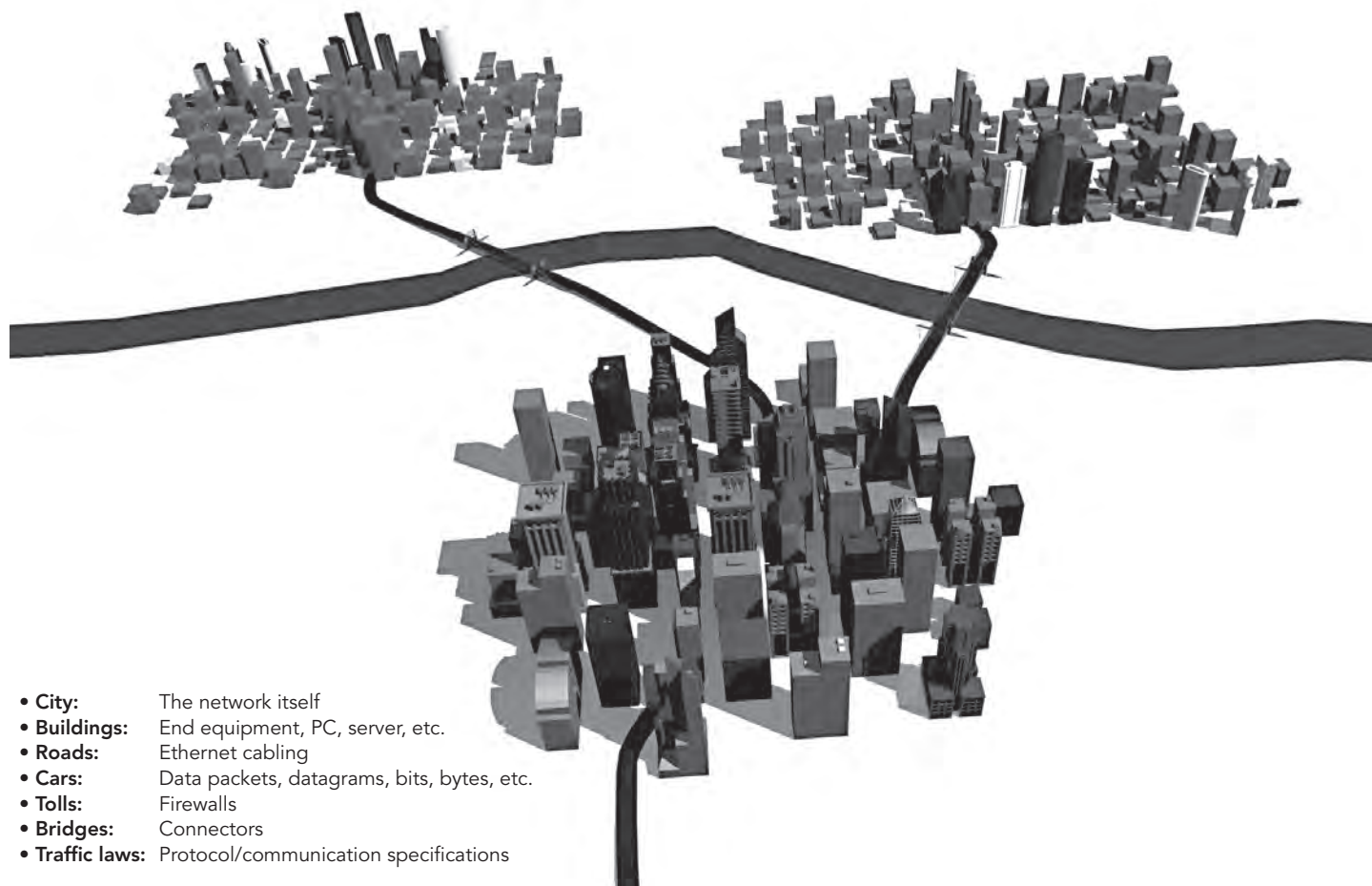

- **City:** The network itself
- **Buildings:** End equipment, PC, server, etc.
- **Roads:** Ethernet cabling
- **Cars:** Data packets, datagrams, bits, bytes, etc.
- **Tolls:** Firewalls
- **Bridges:** Connectors
- **Traffic laws:** Protocol/communication specifications

Ethernet Basics

Ethernet is a widely used communications protocol that is used to transmit data packets (datagrams) between network devices. Imagine a highway in a large metropolitan area six lanes wide at rush hour. The vehicles on the highway need rules to follow so that they get to their destination without crashing into each other. In an Ethernet network link, there could be 100 million bits of information transmitted in one second. In the Ethernet standard, there exist rules to govern packet structure, transmission requirements, error correction, communication with end equipment, etc.

Examining the differences between 100Mhz, 100 Base TX, Cat5e/Cat6. What does it all mean?

When discussing connectors and Ethernet, there are a few key details to be aware of:

- 100Mhz is a measurement of Frequency for the signal
 - Comparable to the Speed Limit of a highway
- 100BaseTX (or Fast Ethernet) is an Ethernet link standard and identifies available link bandwidth. The bandwidth is measured in units of MBits/S (megabits per second)
 - Comparable to the number of cars that pass a point in one second
- Cat5e/Cat6 are an EIA/TIA standard for performance and physical characteristics for cables and connectors
 - Comparable to performance specifications of the car and highway.

In connectors and cables, Fast Ethernet uses 2 pairs. One for transmit and one for receive. This way data traffic can flow in both directions simultaneously.

Ethernet for the Layman (Continued)

SOURIAU offering:

Standard solutions.

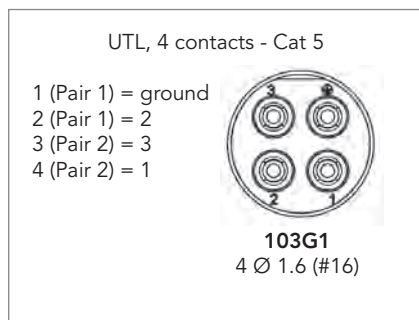

What about using coax contacts ?

Ethernet twisted pairs carry a symmetrical (balanced) signal. Once terminated into a coax contact, the inner core will be protected by a shield - but not the outer contact. Because of EMI issues, the signal will no longer be balanced. Conclusion - it does not work and is not recommended.

What about using Quadrax contacts ?

The Quadrax contact is used in railway applications because of the use of quad cable. In this specific market, the standard Ethernet twisted pairs wires cannot be offered, they are too thin and often solid (not stranded).

In the rest of industry, UTP (Unshielded Twisted Pairs) cables are widely used. The Quadrax contact is not designed to terminate them. And thus, are not advised for industrial applications.

Conclusion

To carry 100Mb/s data signal, 100BaseTX or Fast Ethernet recommends the use of Cat5e connectors as well as Cat5e cable with the support of a 100MHz signal. Nevertheless, a 100Mb/s signal can be transmitted in certain conditions (short distance, only one connector, lower frequency but a different code) thru many other connection materials - not necessarily Cat5e rated.

RS-485 for the Layman

RS-485 signals are used in a wide range of applications (from computers and networks to building automation and stage lighting). In addition, it may be used to control video surveillance systems or to interconnect security control panels and devices such as access control card readers.

RS-485 Basics

RS-485 only specifies electrical characteristics of the generator and the receiver. It does not specify or recommend any communications protocol, only the physical layer. A RS-485 network consists of a single controller (the master) and one or up to 32 slave devices (the receivers). For example, a lighting console is frequently employed as the controller for a network of slave devices like dimmers, fog machines and intelligent lights.

Physical layer

The standard transmission medium is twisted-pair cable of either #22 or #24 AWG solid wire. Typically, a minimum of two lines are used but a third reference wire may be accommodated. Four-wire cables can also be used if full-duplex operation is desired. The cables may be shielded or unshielded, with unshielded the most common.

The nominal characteristic impedance is 100 or 120 Ω. It also defines three generator interface points (signal lines); "A", "B" and "C". The data is transmitted on "A" and "B" with "C" being used as a ground reference.

Terminating load resistors are required to ensure a matched line condition. Without terminating load resistors, reflections of fast driver edges can cause multiple data edges and subsequent data/signal corruption.

What is DMX?

The DMX for Digital Multiplex is the protocol for stage lighting applications using RS-485 standard.

Example of a DMX simple network

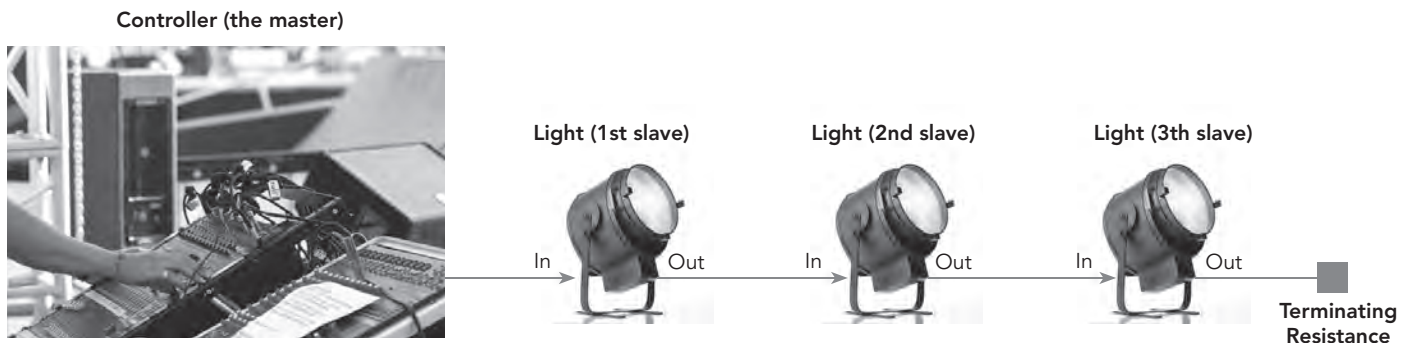

SOURIAU offering:

UTL, 6 contacts - Power + RS 485 1 Twisted pair

1 (Pair 1) = A
 2 (Pair 1) = B
 Ground = C

102G1W3
 3 Ø 1.0 (#20)
 3 Ø 1.6 (#16)

UTL SERIES

Appendices

■ #16 Coaxial Contacts - Cabling Notices	66
■ Glossary of Terms	73
■ Part Number Index	74

#16 Coaxial Contacts

Coaxial Cable - Contact Monocrimp and Multipiece

Cable type	Impe-dance	Contact type	Ø over jacket		Ø over dielectric		Inner cond size Ext. Ø mm	Ø outer braid		Male contact kit for coaxial cable	Female contact kit for coaxial cable	
			inch	mm	inch	mm		inch	mm			
RG161/U	75	Multi piece	0.09"	2.29	0.057"	1.45	-	-	-	RMDXK10D28	RCDXK1D28	
RG179A/U	75		0.105"	2.67	0.063"	1.6	0.3	0.084"	2.13 max			
RG179B/U	75		0.105"	2.67	0.063"	1.6	0.3	0.084"	2.13 max			
RG187/U	75		0.11"	2.79 max	0.06"	1.52	0.3					
RG188/U	50		0.11"	2.79 max	0.06"	1.52	0.51	0.078"	1.98 max			
RG174/U	50		0.11"	2.92	0.06"	1.52	0.48	0.088"	2.24 max			
AMPHENOL 21-598	50		0.105"	2.67	0.06"	1.52	0.48	-	-			
RG196/U	50		0.08"	2.03 max	0.034"	0.086	0.3	-	-			
RG178A/U	50		0.075"	1.91	0.034"	0.86	0.3	0.054"	1.37 max			
RG/188A/U	50	Mono crimp	0.110"	2.79	0.06"	1.52	0.51	0.078"	1.98 max	RMDX6036D28	RCDX6036D28	
KX21TVT (europe) RG178 B/U	50		0.075"	1.91	0.034"	0.86	0.3	0.054"	1.37 max	RMDX6034D28	RCDX6034D28	
RG178 / BU	50		0.075"	1.91	0.034"	0.86	0.3	0.054"	1.37 max	RMDX6050D28	RCDX6016D28	
RG174/U	50		0.115"	2.92	0.06"	1.52	0.48	0.088"	2.24 max	RMDX6032D28	RCDX6032D28	
RG188A/U	50		0.11"	2.79	0.06"	1.52	0.51	0.078"	1.98 max	RMDX6036D28	RCDX6036D28	
RG316/U	50		0.107"	2.72	0.06"	1.52	0.51	0.078"	2.05 max	RMDX6036D28	RCDX6036D28	
raychem 5024A3111	50		0.12"	3.05	0.083"	2.11	0.64	0.097"	2.46	RMDX6052D28	RCDX6052D28	
raychem 5026e1614	50		0.083"	2.11	0.05"	1.27	0.48	0.067"	1.7	RMDX6036D28	RCDX6036D28	
surprenant pn 8134	-		Multi piece	0.1"	2.54	0.058"	1.47	0.3	-	-	RMDXK10D28	RCDXK1D28
PRD PN 247AS-C1123-001	-		Mono crimp	0.103"	2.62	0.06"	1.52	0.51	0.078"	1.98	RMDX6018D28	RCDX6018D28
PRD PN 247AS-C1251	-	0.092"		2.34	0.05"	1.27	0.64	0.067"	1.7	RMDX6018D28	RCDX6018D28	
JUDD C15013010902	-	0.087"		2.13	0.05"	1.27	0.48	0.066"	1.67	RMDX6036D28	RCDX6036D28	
CDC PIN22939200	-	0.09"		2.29	0.048"	1.22	0.3	0.064"	1.63	RMDX6046D28	RCDX6016D28	
CDC PIN22939200	-	0.09"		2.29	0.048"	1.22	0.3	0.064"	1.63	RMDX6050D28	RCDX6016D28	
CDC PIN245670000	-	0.104"		2.64	0.067"	1.7	0.3	0.083"	2.11	RMDX6050D28	RCDX6016D28	
ampex	-	0.114"		2.9	0.075"	1.91	0.38	0.09"	1.29	RMDX6032D28	RCDX6032D28	
TI PN 920580	-	0.7"		1.78	0.038"	0.96	0.48	0.054v	1.37	RMDX6024D28	RCDX6024D28	
Honeywell PN 58000062	-	0.12"		3.05	0.077"	1.96	0.41 solid	0.096"	2.44	RMDX6026D28	RCDX6026D28	
-	-	0.104"		2.64	0.067"	1.7	0.3	-	2.11	RMDX6050D28	-	
-	-	0.09"		2.29	0.048"	1.22	0.3	-	1.63	RMDX6050D28	-	
-	-	0.114"		2.9	0.075"	1.91	0.38	-	1.29	RMDX6032D28	RCDX6032D28	
-	-	0.07"		1.78	0.038"	0.96	0.48	-	1.37	RMDX6024D28	RCDX6024D28	
-	-	0.12"	3.05	0.077"	1.96	0.41	-	2.44	RMDX6026D28	RCDX6026D28		

Twisted Cable - Contact Monocrimp and Multipiece

Cable type	Contact type	Inner AWG cond	Ø over jacket (single wire)		Inner cond size		Ø outer braid		Male contact kit for coaxial cable	Female contact kit for coaxial cable
			inch	mm	Stranded definition	Ext. Ø mm	inch	mm		
2#24 stranded MIL-W-16878 type B	Multi piece	24	0.049"	1.24 max	7/.008		-	-	RMDXK1ØD28	RCDXK1D28
2 #24 solid MIL-W-76 type LW		24	0.047"	1.12 max	1/.0201		-	-	RMDXK1ØD28	RCDXK1D28
2 #26 stranded MIL-W-76 type LW or MIL-W-16878 type B&E		26	0.043"	1.09 max	7/.0063	0.16	-	-	RMDXK1ØD28	RCDXK1D28
2 #28 solid MIL-W-81822/3		28	0.028"	0.71 max			-	-	RMDXK1ØD28	RCDXK1D28
Twisted pair 1/.201 solid MIL-W-76 type LW or MIL-W-16878		26	0.044"	1.12 max	1/.0201	0.511	-	-	RMDXK1ØD28	RCDXK1D28
Twisted pair solid MIL-W-81822/3		28	0.028"	0.71 max	1/.0126	0.32	-	-	RMDXK1ØD28	RCDXK1D28
#28 7/.0036 per Hitachi spec ec-711 (13-2820)	Mono crimp	-	0.046"	1.17	7/.0036	-	-	-	RMDX6Ø31D28 + YØRXØ9Ø	RCDX6Ø31D28 + YØRXØ9Ø
20218201		-	0.028"	0.71	-	-	-	-	RMDX6Ø31D28 + YØRXØ9Ø	RCDX6Ø31D28 + YØRXØ9Ø
#30 solid		-	0.025"	0.64	-	-	-	-	RMDX6Ø15D28 + YØRXØ9Ø	RCDX6Ø15D28 + YØRXØ9Ø
#26 7/.0063		26	0.028"	0.71	7/.063	0.16	-	-	RMDX6Ø31D28 + YØRXØ9Ø	RCDX6Ø31D28 + YØRXØ9Ø
#26 19/.004		26	0.049"	1.24	19/.004	-	-	-	RMDX6Ø19D28 + YØRXØ9Ø	RCDX6Ø19D28 + YØRXØ9Ø
#24 7/.008		24	0.049"	1.24	7/.008	-	-	-	RMDX6Ø19D28 + YØRXØ9Ø	RCDX6Ø19D28 + YØRXØ9Ø
#24 19/.005		24	0.057"	1.45	19/.005	-	-	-	RMDX6Ø19D28 + YØRXØ9Ø	RCDX6Ø19D28 + YØRXØ9Ø
-		26	-	1.25	-	-	-	19x0.1	RMDX6Ø19D28 + YØRXØ9Ø	RCDX6Ø19D28 + YØRXØ9Ø
-		24	-	1.25	-	-	-	7x0.2	RMDX6Ø19D28 + YØRXØ9Ø	RCDX6Ø19D28 + YØRXØ9Ø
-		24	-	1.45	-	-	-	19x0.13	RMDX6Ø19D28 + YØRXØ9Ø	RCDX6Ø19D28 + YØRXØ9Ø
-		26	-	0.7	-	-	-	7x0.16	RMDX6Ø31D28 + YØRXØ9Ø	RCDX6Ø31D28 + YØRXØ9Ø

#16 Coaxial Contacts (Continued)

Twisted Pair Cable Multipiece Contact Cabling

Cable reference	Contact type	Male contact	Female contact	Crimp tool	Die set	Stop bushing	Cable strip length			Inner conductor crimp		Braid crimp	
							A	B	C	g dim	t dim	g dim	t dim
2#24 stranded mil w 16878 type B	Multi piece	RMDXK10D28	RCDXK1D28	M10S1J	-	-	See assembly notice						
2 #24 solid mil-w-76 type LW													
2 #26 stranded mil w 76 type LW or mil w16878 type B & E													
2 #28 solid mil-w-81822/3													
twisted pair 1/.201 solid mil w 76 type LW or mil w 16878													
twisted pair solid mil w 81822/3													

Female contact

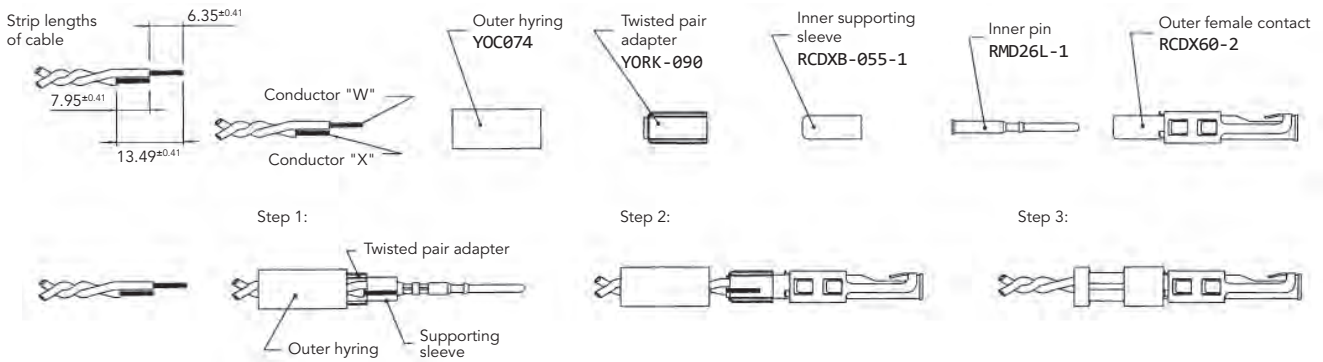

Male contact

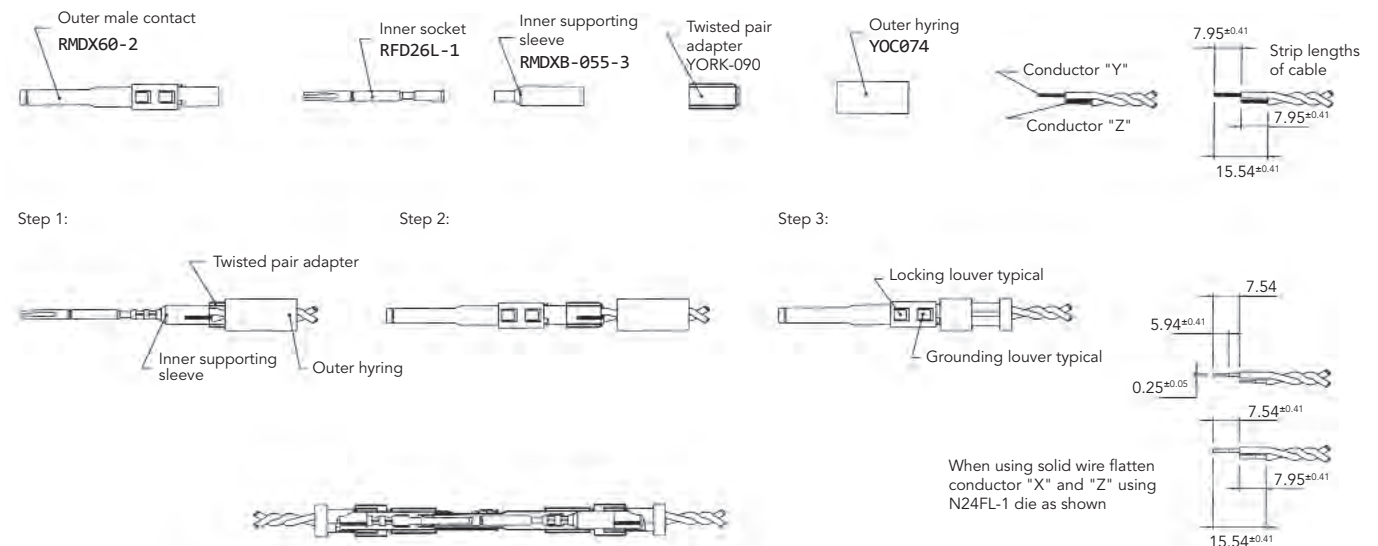

Twisted Pair Cable Monocrimp Contact Cabling

Cable reference	Contact type	Male contact	Female contact	Crimp tool	Die set	Stop bushing	Cable strip length			Inner conductor crimp		Braid crimp	
							A	B	C	g dim	t dim	g dim	t dim
#28 7/.0036 per Hitachi spec ec-711 (13-2820)	Mono crimp	RMDX6031D28 + YORX090	RCDX6031D28 + YORX090	M1051J	S80	SL105	4.7	6.1	4.32	1.30 to 1.12	1.4 to 1.22	2.97 to 2.84	3.07 to 2.9
20218204					S80	SL105	3.94	6.1	3.16	1.30 to 1.17	1.4 to 1.22	2.97 to 2.84	3.07 to 2.79
#30 solid					S83	SL105	4.7	6.1	4.06	1.22 to 1.12	1.35 to 1.22	2.97 to 2.84	3.12 to 2.95
#26 7/.0063					S80	SL105	4.7	6.1	4.06	1.30 to 1.17	1.4 to 1.22	2.97 to 2.84	3.07 to 2.9
#26 19/.004					M105G8 ASSY Y TOOL DIE SET STOP BUSHING M1051J TOOL	4.7	6.1	4.06	1.22 to 1.17	1.35 to 1.22	2.84 to 2.79	3.12 to 2.97	
#24 7/.008						4.7	6.1	4.06	1.22 to 1.17	1.35 to 1.22	2.84 to 2.79	3.12 to 2.97	
#24 19/.005						4.7	6.1	4.06	1.22 to 1.17	1.35 to 1.22	2.84 to 2.79	3.12 to 2.97	
AWG26 (19x0.1)					M105G8 crimping kit	4.7	6	4					
AWG24 (7x0.2)													
AWG24 (19x0.13)													
AWG26 (7x0.16)													

- Select appropriate monocrimp coax twisted pair contact and cable combination.
- Select appropriate crimp tooling (hand tool, S-die set, stop bushing).
- Strip the twisted pair cable to the designated wire strip lengths.
- Insert the stripped cable into the contact. One cable is to be inserted into the inside diameter of hyring, and pushed forward into the inner contact. The second cable is to be inserted between the outside diameter of hyring and the inside diameter of the outer contact body.
- Crimp the contact.

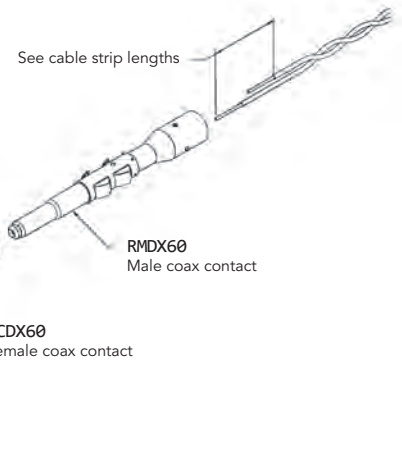

Cable strip length

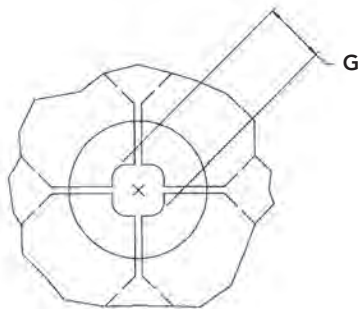
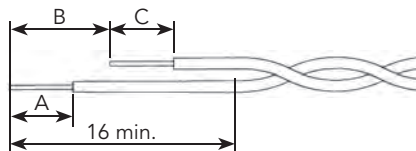

Braid crimp (G) to be measured with die set fully closed

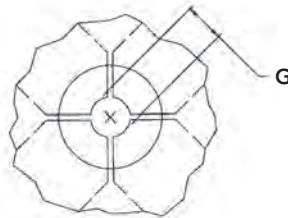

Inner conductor crimp (G) to be measured with die set fully closed

Note : all dimensions are in mm

#16 Coaxial Contacts (Continued)

Multipiece Male Contact with Coax Cable

Cable reference	Contact	Hyring complementary components	Outer contact crimp tool		Inner contact crimp tool		Cable strip length		
			Crimp tool M10S1J		Crimp tool M10S1J		A	B	C
			Die set	Stop bushing	Die set	Stop bushing			
RG161U	Male: RMDXK10D28	YOC074	S221	SL471	S23D2	SL46D2	4.37	7.95	15.88
RG179							4.37	7.95	15.88
RG187U							4.37	7.95	15.88
RG188/U							4.37	7.95	15.88
RG174/U		YOC074 + RMDXB0553			7.54		9.12	17.53	
RG178A/U					7.54		9.12	17.53	
RG196U					-		-	-	
AMPHENOL 21-598		YOC074			4.37		7.95	15.88	
surprenant pn 8134					-		-	-	

Multipiece kit details

RMDXK10D28 includes	RMDX602D28	Outer contact
	RFD26L1D28	Inner contact
	YOC074	Outer hyring
	RMDXB0553	Inner supporting sleeve

Cable strip length

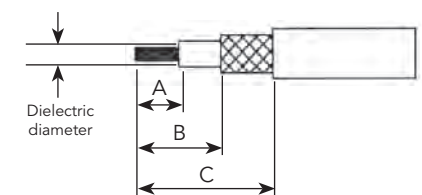

Contact assembly with dielectric diameter over 1.4mm - without inner supporting sleeve

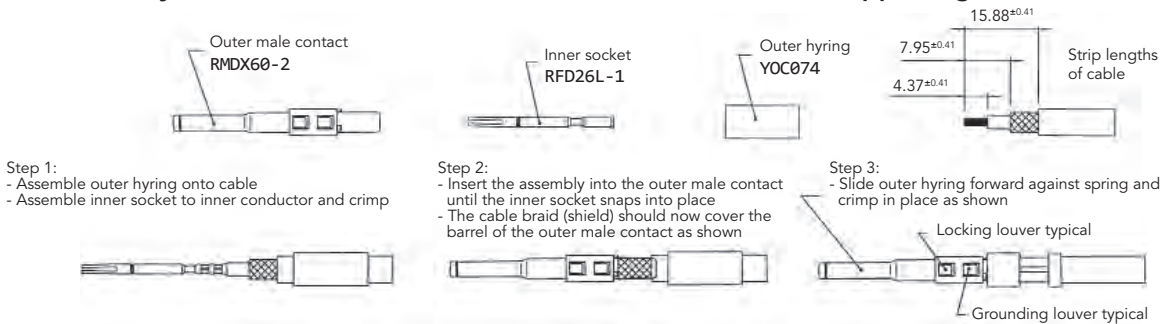

Contact assembly with dielectric diameter under 1.4mm - with inner supporting sleeve

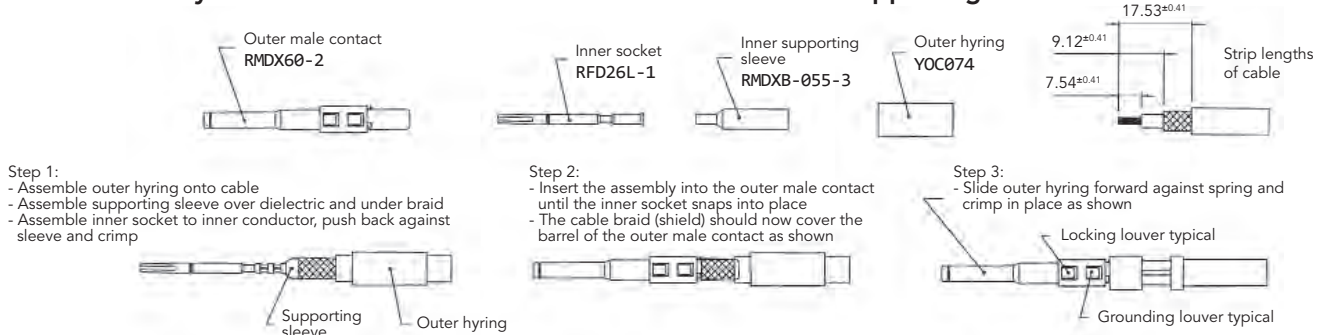

Note : all dimensions are in mm

Multipiece Female Contact with Coax Cable

Cable reference	Contact	Hyring complementary components	Outer contact crimp tool		Inner contact crimp tool		Cable strip length		
			Crimp tool M10S1J		Crimp tool M10S1J		A	B	C
			Die set	Stop bushing	Die set	Stop bushing			
RG161U	Female: RCDXK1D28	YOC074	S221	SL471	S23D2	SL46D2	4.37	-	11.13
RG179							4.37		11.13
RG187U							4.37		11.13
RG188/U							4.37		11.13
RG174/U							4.37		11.13
RG178A/U		YOC074 + RMDXB0553			6.35		11.13		
RG196U		6.35			11.13				
AMPHENOL 21-598		YOC074			4.37		11.13		
surprenant pn 8134		-			4.37		11.13		

Multipiece kit details

RCDXK1D28 includes	Part	Description
	RCDX602D28	Outer contact
	RMD26L1D28	Inner contact
	YOC074	Outer hyring
	RCDXB0553	Inner supporting sleeve

Cable strip length

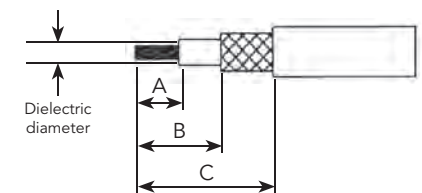

Contact assembly with dielectric diameter over 1.4mm - without inner supporting sleeve

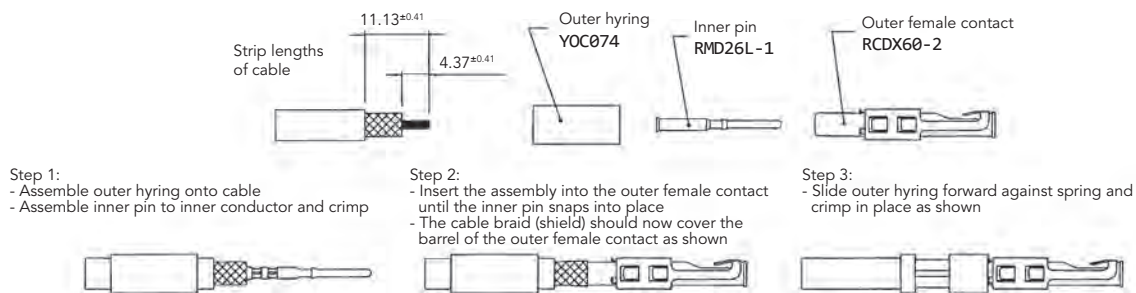

Contact assembly with dielectric diameter under 1.4mm - with inner supporting sleeve

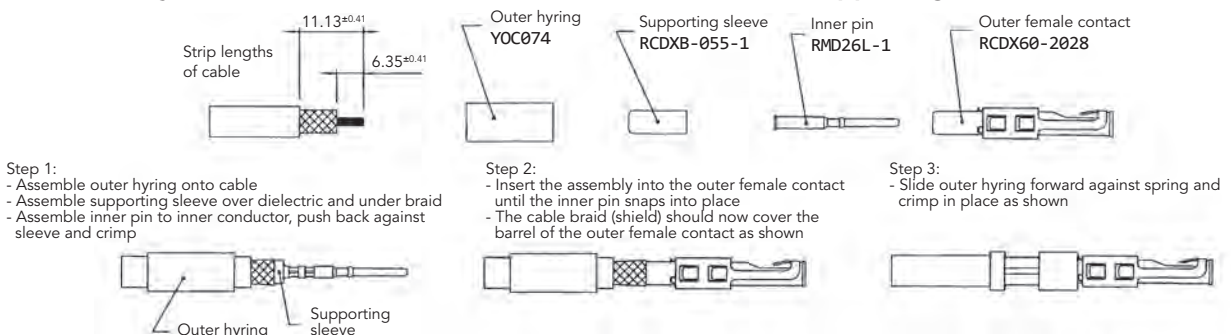

Note : all dimensions are in mm

#16 Coaxial Contacts (Continued)

Coax Cable with Monocrimp Contact Cabling

Cable reference	Male contact	Female contact	Crimp tool	Die set	Stop bushing	Cable strip length			Inner conductor crimp		Braid crimp	
						A	B	C	g dim	t dim	g dim	t dim
CDC PIN22939200	RMDX6046D28	RCDX6016D28	M10S1J	S80	SL105	4.19	5.97	8.51	1.30/1.17	1.40/1.22	2.77/2.64	3.02/2.84
CDC PIN22939200	RMDX6046D28	RCDX6016D28		S87	SL105	5.08	6.35	8.89	1.30/1.17	1.40/1.22	2.77/2.64	3.02/2.84
CDC PIN245670000	RMDX6050D28	RCDX6016D28		S80	SL105	5.08	6.35	8.89	1.30/1.17	1.40/1.22	2.97/2.84	3.12/2.95
KX21TVT (europe) RG178 B/U	RMDX6034D28	RCDX6034D28		S82	SL105	5.08	6.35	8.89	1.30/1.17	1.32/1.17	2.84/2.74	3.07/2.9
RG178 / BU	RMDX6050D28	RCDX6016D28		S87	SL105	5.08	6.35	8.89	1.30/1.17	1.40/1.22	2.77/2.64	3.02/2.84
ampex	RMDX6032D28	RCDX6032D28		S80	SL105	5.08	6.35	11.68	1.30/1.17	1.40/1.22	2.97/2.84	3.12/2.95
TI PN 920580	RMDX6024D28	RCDX6024D28		S82	SL105	5.08	6.35	8.89	1.35/1.19	1.42/1.27	2.87/2.74	3.07/2.9
RG174/U	RMDX6032D28	RCDX6032D28		S80	SL105	5.08	6.35	11.68	1.30/1.17	1.40/1.22	2.97/2.84	3.12/2.95
Honeywell PN 58000062	RMDX6026D28	RCDX6026D28		S82	SL105	5.08	6.35	8.89	1.35/1.19	1.42/1.27	2.87/2.74	3.07/2.9
RG188A/U	RMDX6036D28	RCDX6036D28		S80	SL105	5.08	6.35	11.68	1.30/1.17	1.40/1.22	2.97/2.84	3.12/2.95
RG316/U	RMDX6036D28	RCDX6036D28		S80	SL105	5.08	6.35	11.68	1.30/1.17	1.40/1.22	2.97/2.84	3.12/2.95
PRD PN 247AS-C1123-001	RMDX6018D28	RCDX6018D28		M10S88 ASSY'Y TOOL DIE SET STOP BUSHING M10S1J TOOL		5.08	6.35	8.89	1.22/1.17	1.35/1.22	2.92/2.79	3.12/2.97
PRD PN 247AS-C1251	RMDX6018D28	RCDX6018D28				5.08	6.35	8.89	1.22/1.17	1.35/1.22	2.92/2.79	3.12/2.97
raychem 5024A3111	RMDX6052D28	RCDX6052D28		S88	SL105	5.08	6.35	11.68	1.37/1.27	1.45/1.32	2.92/2.79	
raychem 5026e1614	RMDX6036D28	RCDX6036D28		M10S88 ASSY'Y TOOL DIE SET STOP BUSHING M10S1J TOOL		5.08	6.35	8.89	1.22/1.17	1.35/1.22	2.92/2.79	3.12/2.97
JUDD C15013010902	RMDX6036D28	RCDX6036D28				5.08	6.35	8.89	1.22/1.17	1.35/1.22	2.92/2.79	3.12/2.97
inner cond. #30, braid diam 2.64	RMDX6050D28	-		S80	SL105	5.1	6.35	8.9	-	-	-	-
inner cond. #30, braid diam 2.29	RMDX6050D28	-		S87	SL105	4.2	6.35	8.5	-	-	-	-
inner cond. #28, braid diam 2.9	RMDX6032D28	RCDX6032D28		S80	SL105	5.1	6.35	11.7	-	-	-	-
inner cond. #26, braid diam 1.78	RMDX6024D28	RCDX6024D28		S82	SL105	5.1	6.35	8.9	-	-	-	-
inner cond. #26, braid diam 3.05	RMDX6026D28	RCDX6026D28	S82	SL105	5.1	6.35	8.9	-	-	-	-	

- Select appropriate cable and contact combination.
- Select appropriate crimp tooling (hand tool, S-die set, stop bushing).
- Strip coax cable to the designated wire strip lengths.
- Insert the stripped coax into the rear of the contact.
- Crimp the contact.

Cable strip length

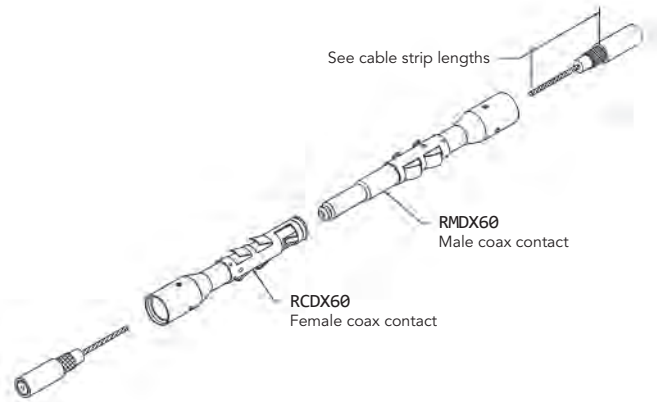
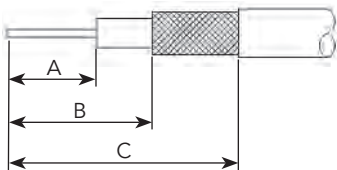

Glossary of Terms

- **Clearance**

Per the IEC 60664-1 it is the shortest distance between two conductive parts even over the air.

- **Creepage distance**

Per the IEC 60664-1 it represents the shortest distance along the surface of the insulating material between two conductive parts.

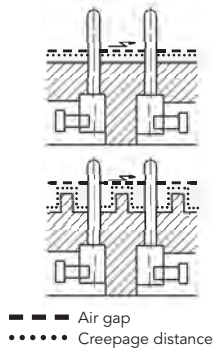

- **Working voltage**

Per the IEC 60664-1 it is the highest r.m.s. value of A.C. or D.C. voltage across any particular insulation which can occur when the equipment is supplied at rated voltage.

- **Rated impulse voltage**

Impulse withstands voltage value assigned by the manufacturer to the equipment or to a part of it characterizing the specified withstand capability of its insulation against transient overvoltage.

- **Working current**

It is the maximum continuous and not interrupted current able to be carried by all contacts without exceeding the maximum temperature of the insulating material.

- **Transient voltage**

Extract from the IEC 60664-1: Short duration overvoltage of a few millisecond or less, oscillatory or non-oscillatory, usually highly damped.

- **CTI (Comparative Tracking Index)**

The CTI value is commonly used to characterize the electrical breakdown properties of an insulating material. It allows users to know the tendency to create creepage paths. This value represents the maximum voltage after 50 drops of ammonium chloride solution without any breakdown.

- **RTI (Relative temperature Index):**

Extract from ULs website:

Maximum service temperature for a material, where a class of critical property will not be unacceptably compromised through chemical thermal degradation, over the reasonable life of an electrical product, relative to a reference material having a confirmed, acceptable corresponding performance defined RTI.

- **RTI Elec:** Electrical RTI, associated with critical electrical insulating properties.
- **RTI Mech Imp:** Mechanical Impact RTI, associated with critical impact resistance, resilience and flexibility properties.
- **RTI Mech Str:** Mechanical Strength (Mechanical without Impact) RTI, associated with critical mechanical strength where impact resistance, resilience and flexibility are not essential.

Part Number Index

Connector

UTL1102G1W3P..... P. 22
 UTL1102G1W3P03..... P. 22
 UTL1102G1W3PCDMX..... P. 22
 UTL1102G1W3S..... P. 22
 UTL1102G1W3S03..... P. 22
 UTL1102G1W3SCDMX..... P. 22
 UTL1103G1P..... P. 18
 UTL1103G1P03..... P. 18
 UTL1103G1S..... P. 18
 UTL1103G1S03..... P. 18
 UTL6102G1W3P..... P. 22
 UTL6102G1W3P03..... P. 22
 UTL6102G1W3PCDMX..... P. 22
 UTL6102G1W3S..... P. 22
 UTL6102G1W3S03..... P. 22
 UTL6102G1W3SCDMX..... P. 22
 UTL6103G1P..... P. 18
 UTL6103G1P03..... P. 18
 UTL6103G1S..... P. 18
 UTL6103G1S03..... P. 18
 UTL7102G1W3P..... P. 22
 UTL7102G1W3P03..... P. 22
 UTL7102G1W3S..... P. 22
 UTL7102G1W3S03..... P. 22
 UTL7103G1P..... P. 18
 UTL7103G1P03..... P. 18
 UTL7103G1S..... P. 18
 UTL7103G1S03..... P. 18

Overmoulded cable Assembly

HAUTL12G1W3PR1M..... P. 22
 HAUTL12G1W3PR2M..... P. 22
 HAUTL12G1W3PS1M..... P. 22
 HAUTL12G1W3PS2M..... P. 22
 HAUTL12G1W3SR1M..... P. 22
 HAUTL12G1W3SR2M..... P. 22
 HAUTL12G1W3SS1M..... P. 22
 HAUTL12G1W3SS2M..... P. 22
 HAUTL13G1PR1M..... P. 18
 HAUTL13G1PR2M..... P. 18
 HAUTL13G1PS1M..... P. 18
 HAUTL13G1PS2M..... P. 18
 HAUTL13G1SR1M..... P. 18
 HAUTL13G1SR2M..... P. 18
 HAUTL13G1SS1M..... P. 18
 HAUTL13G1SS2M..... P. 18
 HAUTL62G1W3PR1M..... P. 22
 HAUTL62G1W3PR2M..... P. 22
 HAUTL62G1W3PS1M..... P. 22
 HAUTL62G1W3PS2M..... P. 22
 HAUTL62G1W3SR1M..... P. 22
 HAUTL62G1W3SR2M..... P. 22
 HAUTL62G1W3SS1M..... P. 22
 HAUTL62G1W3SS2M..... P. 22
 HAUTL63G1PR1M..... P. 18
 HAUTL63G1PR2M..... P. 18
 HAUTL63G1PS1M..... P. 18
 HAUTL63G1PS2M..... P. 18
 HAUTL63G1SR1M..... P. 18
 HAUTL63G1SR2M..... P. 18
 HAUTL63G1SS1M..... P. 18
 HAUTL63G1SS2M..... P. 18

Evaluation Kit

UTL1102G1W3P14AWG..... P. 50
 UTL1102G1W3P16AWG..... P. 50
 UTL6102G1W3P14AWG..... P. 50
 UTL6102G1W3P16AWG..... P. 50
 UTL7102G1W3P14AWG..... P. 50
 UTL7102G1W3P16AWG..... P. 50
 UTL1102G1W3S14AWG..... P. 50
 UTL1102G1W3S16AWG..... P. 50
 UTL6102G1W3S14AWG..... P. 50
 UTL6102G1W3S16AWG..... P. 50
 UTL7102G1W3S14AWG..... P. 50
 UTL7102G1W3S16AWG..... P. 50
 UTL0103G1P14AWG..... P. 49
 UTL0103G1P16AWG..... P. 49
 UTL0103G1P20AWG..... P. 49
 UTL1103G1P14AWG..... P. 49
 UTL1103G1P16AWG..... P. 49
 UTL1103G1P20AWG..... P. 49
 UTL6103G1P14AWG..... P. 49
 UTL6103G1P16AWG..... P. 49
 UTL6103G1P20AWG..... P. 49
 UTL7103G1P14AWG..... P. 49
 UTL7103G1P16AWG..... P. 49
 UTL7103G1P20AWG..... P. 49
 UTL0103G1S14AWG..... P. 49
 UTL0103G1S16AWG..... P. 49
 UTL0103G1S20AWG..... P. 49
 UTL1103G1S14AWG..... P. 49
 UTL1103G1S16AWG..... P. 49
 UTL1103G1S20AWG..... P. 49
 UTL6103G1S14AWG..... P. 49
 UTL6103G1S16AWG..... P. 49
 UTL6103G1S20AWG..... P. 49
 UTL7103G1S14AWG..... P. 49
 UTL7103G1S16AWG..... P. 49
 UTL7103G1S20AWG..... P. 49

Accessories

SWSFILLERPLUG..... P. 20
 UTL102G1W3PDCG68..... P. 24
 UTL102G1W3SDCG68..... P. 24
 UTL103G1PDCG68..... P. 20
 UTL103G1SDCG68..... P. 20
 UTL10DCG..... P. 20
 UTL610DCG..... P. 20

Contacts

RC14M25K..... P. 31
 RC14M30GE7J..... P. 32
 RC14M30GE7K..... P. 32
 RC14M30J..... P. 31
 RC14M30K..... P. 31
 RC16M23GE7J..... P. 32
 RC16M23GE7K..... P. 32
 RC16M23J..... P. 31
 RC16M23K..... P. 31
 RC16M25K..... P. 31
 RC18W3K..... P. 31
 RC20M12E83K..... P. 34
 RC20M12E84K..... P. 34
 RC20M12GE7J..... P. 32
 RC20M12GE7K..... P. 32

RC20M12J..... P. 31
 RC20M12K..... P. 31
 RC20M13GE7J..... P. 32
 RC20M13GE7K..... P. 32
 RC20M13J..... P. 31
 RC20M13K..... P. 31
 RC20W3K..... P. 31
 RC24M9GE7J..... P. 32
 RC24M9GE7K..... P. 32
 RC24M9J..... P. 31
 RC24M9K..... P. 31
 RC24W3K..... P. 31
 RC28M1GE7J..... P. 32
 RC28M1GE7K..... P. 32
 RC28M1J..... P. 31
 RC28M1K..... P. 31
 RCDX6015D28..... P. 67
 RCDX6016D28..... P. 66
 RCDX6018D28..... P. 66
 RCDX6019D28..... P. 67
 RCDX6024D28..... P. 66
 RCDX6026D28..... P. 66
 RCDX602D28..... P. 71
 RCDX6031D28..... P. 67
 RCDX6032D28..... P. 66
 RCDX6034D28..... P. 66
 RCDX6036D28..... P. 66
 RCDX6052D28..... P. 66
 RCDXB0553..... P. 71
 RCDXK1D28..... P. 66
 RFD26L1D28..... P. 70
 RM14M25K..... P. 31
 RM14M30GE1J..... P. 32
 RM14M30GE1K..... P. 32
 RM14M30J..... P. 31
 RM14M30K..... P. 31
 RM16M23GE1J..... P. 32
 RM16M23GE1K..... P. 32
 RM16M23J..... P. 31
 RM16M23K..... P. 31
 RM16M25K..... P. 31
 RM18W3K..... P. 31
 RM20M12E8K..... P. 34
 RM20M12GE1J..... P. 32
 RM20M12GE1K..... P. 32
 RM20M12K..... P. 31
 RM20M13GE1J..... P. 32
 RM20M13GE1K..... P. 32
 RM20M13J..... P. 31
 RM20M13K..... P. 31
 RM20W3K..... P. 31
 RM24M9GE1J..... P. 32
 RM24M9GE1K..... P. 32
 RM24M9J..... P. 31
 RM24M9K..... P. 31
 RM24W3K..... P. 31
 RM28M1GE1J..... P. 32
 RM28M1GE1K..... P. 32
 RM28M1J..... P. 31
 RM28M1K..... P. 31
 RMD26L1D28..... P. 71
 RMDX6015D28..... P. 67
 RMDX6018D28..... P. 66
 RMDX6019D28..... P. 67

RMDX602D28.....	P. 70	SM16M1TK6.....	P. 31
RMDX6024D28.....	P. 66	SM16M11TK6.....	P. 31
RMDX6026D28.....	P. 66	SM16ML1TK6.....	P. 31
RMDX6031D28.....	P. 67	SM16ML11TK6.....	P. 31
RMDX6032D28.....	P. 66	SM20M1S18.....	P. 31
RMDX6034D28.....	P. 66	SM20ML1S18.....	P. 31
RMDX6036D28.....	P. 66	SM20M1S31.....	P. 31
RMDX6046D28.....	P. 66	SM20ML1S31.....	P. 31
RMDX6050D28.....	P. 66	SM20M1TK6.....	P. 31
RMDX6052D28.....	P. 66	SM20ML1TK6.....	P. 31
RMDXB0553.....	P. 70	SM20W3TK6.....	P. 31
RMDXK10D28.....	P. 66	SM20W3S26.....	P. 31
SC14M1S18.....	P. 31	SM20WL3TK6.....	P. 31
SC14ML1S18.....	P. 31	SM20WL3S26.....	P. 31
SC14M1S31.....	P. 31	SM24M1S18.....	P. 31
SC14ML1S31.....	P. 31	SM24ML1S18.....	P. 31
SC14M1TK6.....	P. 31	SM24M1S31.....	P. 31
SC14ML1TK6.....	P. 31	SM24ML1S31.....	P. 31
SC16M1S18.....	P. 31	SM24M1TK6.....	P. 31
SC16M11S18.....	P. 31	SM24ML1TK6.....	P. 31
SC16ML1S18.....	P. 31	SM24W3TK6.....	P. 31
SC16ML11S18.....	P. 31	SM24W3S26.....	P. 31
SC16M1S31.....	P. 31	SM24WL3TK6.....	P. 31
SC16M11S31.....	P. 31	SM24WL3S26.....	P. 31
SC16ML1S31.....	P. 31	YOC074.....	P. 70
SC16ML11S31.....	P. 31		
SC16M1TK6.....	P. 31		
SC16M11TK6.....	P. 31		
SC16ML1TK6.....	P. 31		
SC16ML11TK6.....	P. 31		
SC20M1S18.....	P. 31		
SC20ML1S18.....	P. 31		
SC20M1S31.....	P. 31		
SC20ML1S31.....	P. 31		
SC20M1TK6.....	P. 31		
SC20ML1TK6.....	P. 31		
SC20W3TK6.....	P. 31		
SC20W3S25.....	P. 31		
SC20WL3TK6.....	P. 31		
SC20WL3S25.....	P. 31		
SC24M1S18.....	P. 31		
SC24ML1S18.....	P. 31		
SC24M1S31.....	P. 31		
SC24ML1S31.....	P. 31		
SC24M1TK6.....	P. 31		
SC24ML1TK6.....	P. 31		
SC24W3TK6.....	P. 31		
SC24W3S25.....	P. 31		
SC24WL3TK6.....	P. 31		
SC24WL3S25.....	P. 31		
SM14M1S18.....	P. 31		
SM14ML1S18.....	P. 31		
SM14M1S31.....	P. 31		
SM14ML1S31.....	P. 23		
SM14M1TK6.....	P. 31		
SM14ML1TK6.....	P. 31		
SM16M1S18.....	P. 31		
SM16M11S18.....	P. 31		
SM16ML1S18.....	P. 31		
SM16ML11S18.....	P. 31		
SM16M1S31.....	P. 31		
SM16M11S31.....	P. 31		
SM16ML1S31.....	P. 31		
SM16ML11S31.....	P. 31		

Tooling

M10S1J.....	P. 70
M10SG8.....	P. 71
M317.....	P. 39
MH860.....	P. 39
MH86164G.....	P. 39
MH86186.....	P. 39
RTM205.....	P. 39
RX2025GE1.....	P. 39
RX20D44.....	P. 39
S16RCM14.....	P. 39
S16RCM1425.....	P. 39
S16RCM16.....	P. 39
S16RCM1625.....	P. 39
S16RCM20.....	P. 39
S16SCM20.....	P. 39
S16SCML1.....	P. 39
S16SCML11.....	P. 39
S20RCM.....	P. 39
S20SCM20.....	P. 39
S221.....	P. 70
S23D2.....	P. 70
S80.....	P. 71
S82.....	P. 72
S83.....	P. 71
S87.....	P. 72
S88.....	P. 72
SHANGLES.....	P. 39
SL105.....	P. 71
SL46D2.....	P. 70
SL471.....	P. 70
UH25.....	P. 39

Notes

A large rectangular grid consisting of 28 columns and 30 rows of small squares, provided for taking notes.

Notes

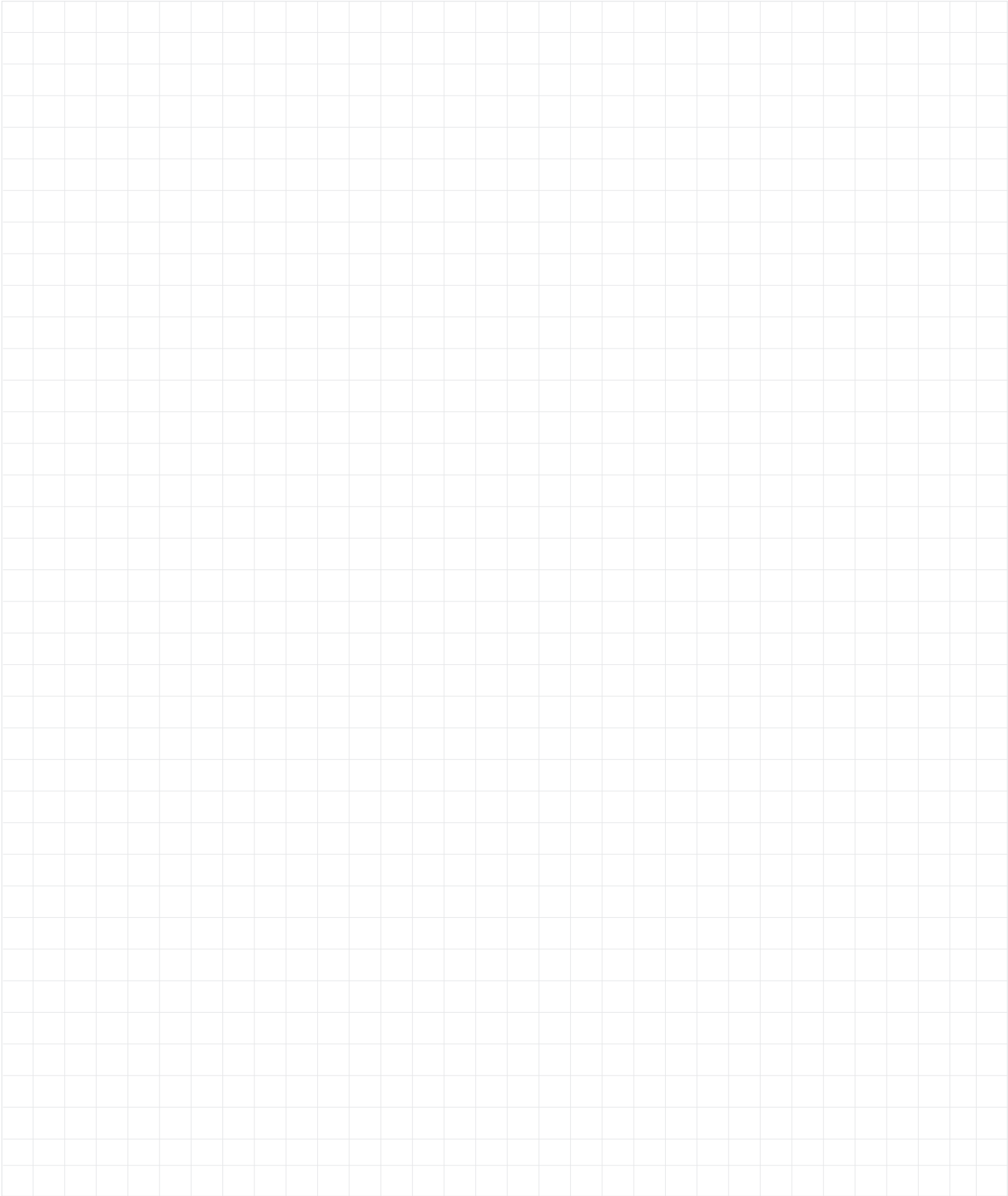

Reliable People, Reliable Solutions

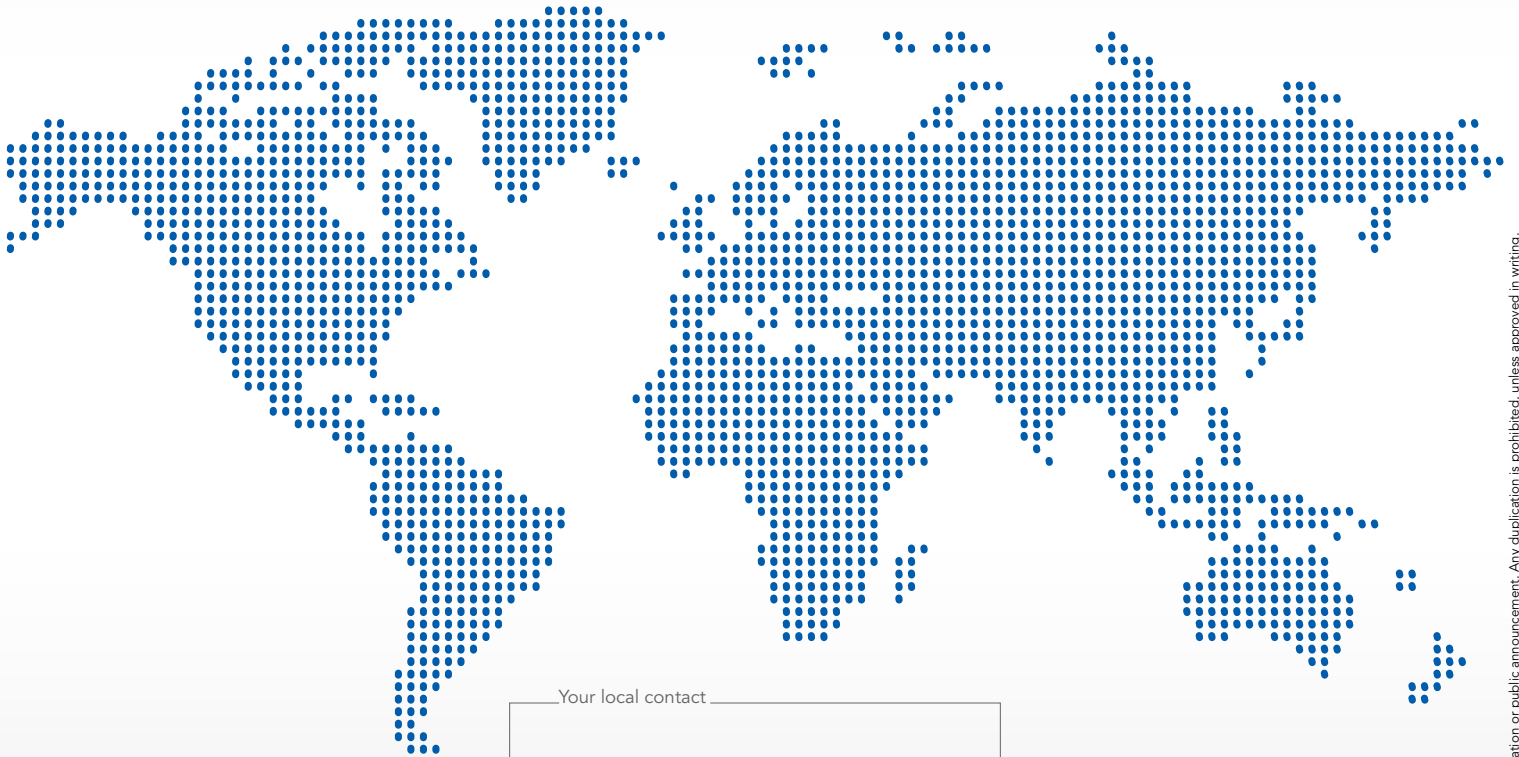

Your local contact



Our contribution to environmental protection:
This catalog is printed on PEFC certified paper
Advancement of sustainable wood cultivation. www.pefc.org

SOURIAU

www.souriau-industrial.com
contactindustry@souriau.com

