



MK 35

Naval Connectors

 **FT electronics**  
AB Connectors Limited

# Company Profile



Operating from the principal site in South Wales, U.K., AB Connectors, a subsidiary of TT electronics plc., is one of the recognised market leaders in design, test and



manufacture of harsh environment interconnection systems, bespoke harness assemblies and equipment sub-units.

With a satellite assembly facility in North Carolina, USA, and a co-ordinated global sales and distribution network, AB Connectors Limited offers an unrivalled service to both engineers and buyers alike.

Through a commitment to a structured new product introduction process, AB Connectors is continuing investment in research and development of new materials and processes, surface treatments and the very latest manufacturing technology and techniques to ensure the products meet the most exacting standards encountered in the

modern Military, Mass Transportation and Industrial market places.

Quality system approvals include BS/EN/ISO

9001 along with product approvals to BS9000, IECQ and CECC. As a result of these qualifications, AB Connectors have been awarded

several major customer approvals and accreditations.

AB Connectors total commitment to providing customers with high levels of service, cost effectiveness, quality and innovative solutions in interconnection products, make it the ideal first choice supply partner.



The AB Connectors Mk35 Connector series is derived from the American Mil-C-38999 Series III specification. The connectors intermate and can be interchanged with the standard Series III connector, but to ensure optimum performance in the most severe environments, Mk35 connectors feature nickel aluminium bronze as the material for shells, coupling nuts and other major components.

Mk35 connectors feature 100% 'scoop proof' design and coupling is achieved by a triple start coarse thread. The connectors also feature a self locking anti-vibration mechanism for secure mating in high vibration environments.

Contacts which conform to Mil-C-39029 are crimp rear insertion, rear extraction and the socket is protected from probe damage by using a restricted entry design.

Sealing between mating connectors is by compression of a interfacial seal and around each individual contact.

A comprehensive range environment/plain backshells and accessories is available.

AB Mk35 connectors are approved to CECC 75 201 002 Specification.



## Specifications

### Standard Materials & Finishes

Shell:	Marine bronze, self finish
Insulator:	Assembly of rigid plastic/silicone rubber
Contacts:	Copper alloy, gold plated

### Mechanical Features

Coupling:	Triple start coarse thread
Polarisation	5 key/keyway
Contact Type:	Crimp, rear insertion, rear release, rear removable
Contact	
Arrangements:	2 to 128 contacts

### Electrical Data

Maximum Contact	
Current Ratings:	3 amps to 16 amps
Voltage Rating:	Working 500V to 2300V DC/AC Peak
Contact Resistance:	5 m ohms max
Temperature Rating:	-65°C to +175°C

# AB Part Number Explanation

## Connectors

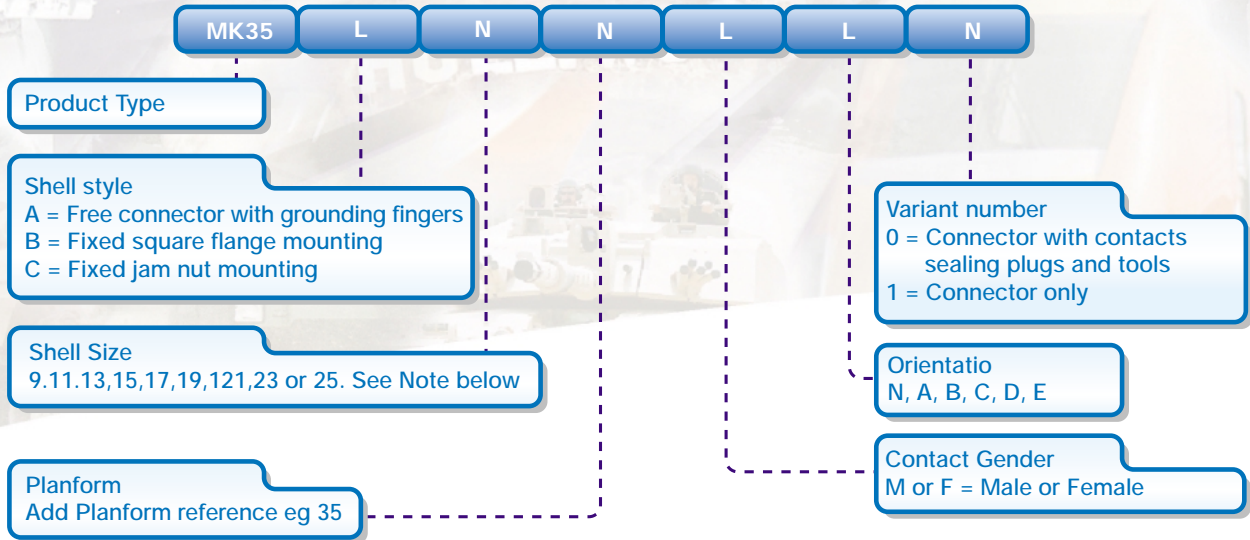

Example MK35 B 13 35 M N O Fixed square flange, 13-35 contact arrangement, male (pin) contacts, N-orientation, supplied with contacts sealing plugs and tools. When translating from the CECC number the Shell size equates to the letter they are, as follows:- A=9, B=11, C=13, D=15, E=17, F=19, G=21, H=23, J=25

## Accessories and Tools

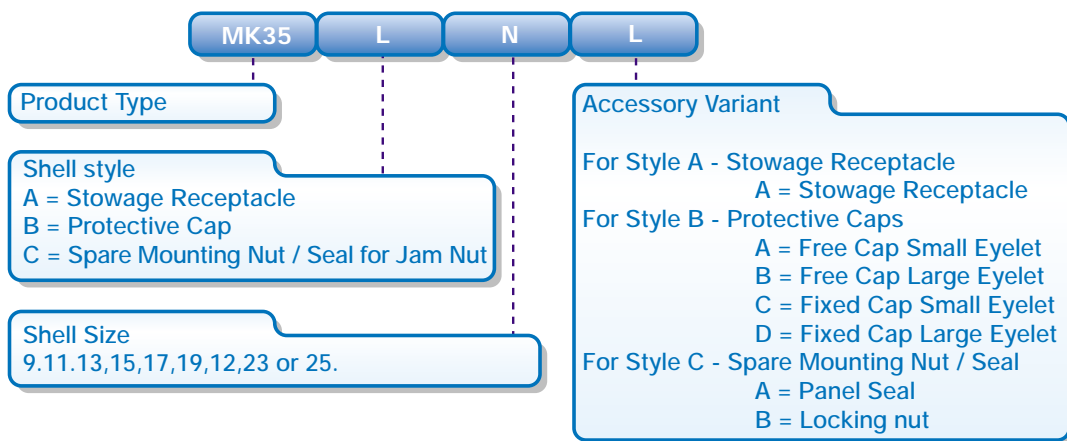

Examples MK35 A 15 A Stowage receptacle Size 15, MK35 B 21 D Fixed protective Gap with Large Eyelet Size 21, MK35 C 13 B Spare Locking nut for a size 13 Jam nut Connector

# CECC Part Number Explanation

Connectors

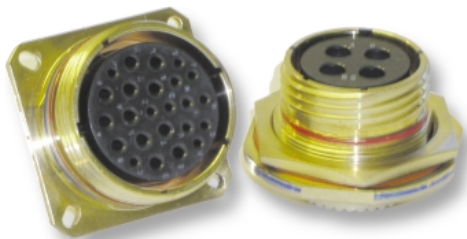
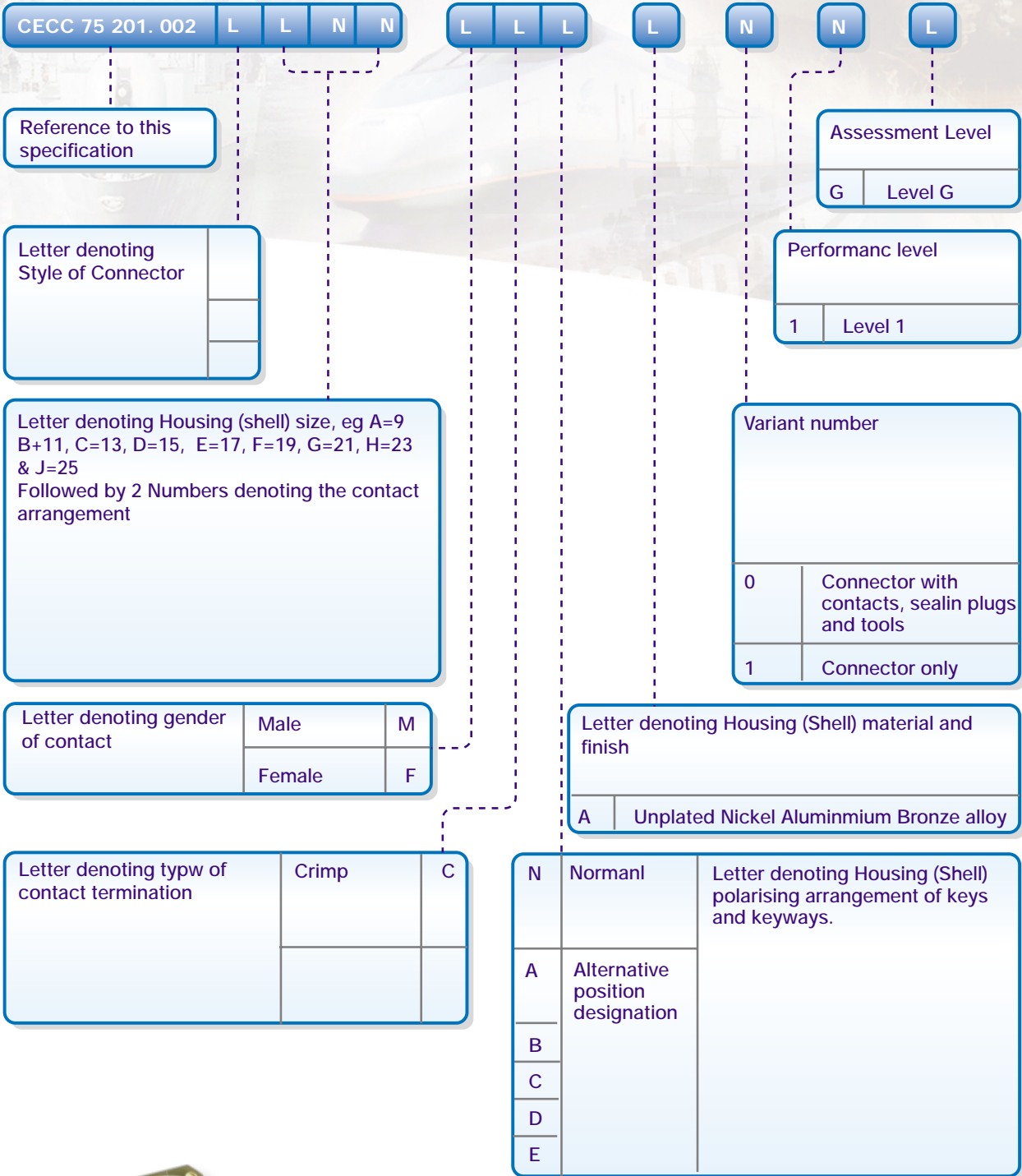

# CECC Part Number Explanation

## Accessories and Tools

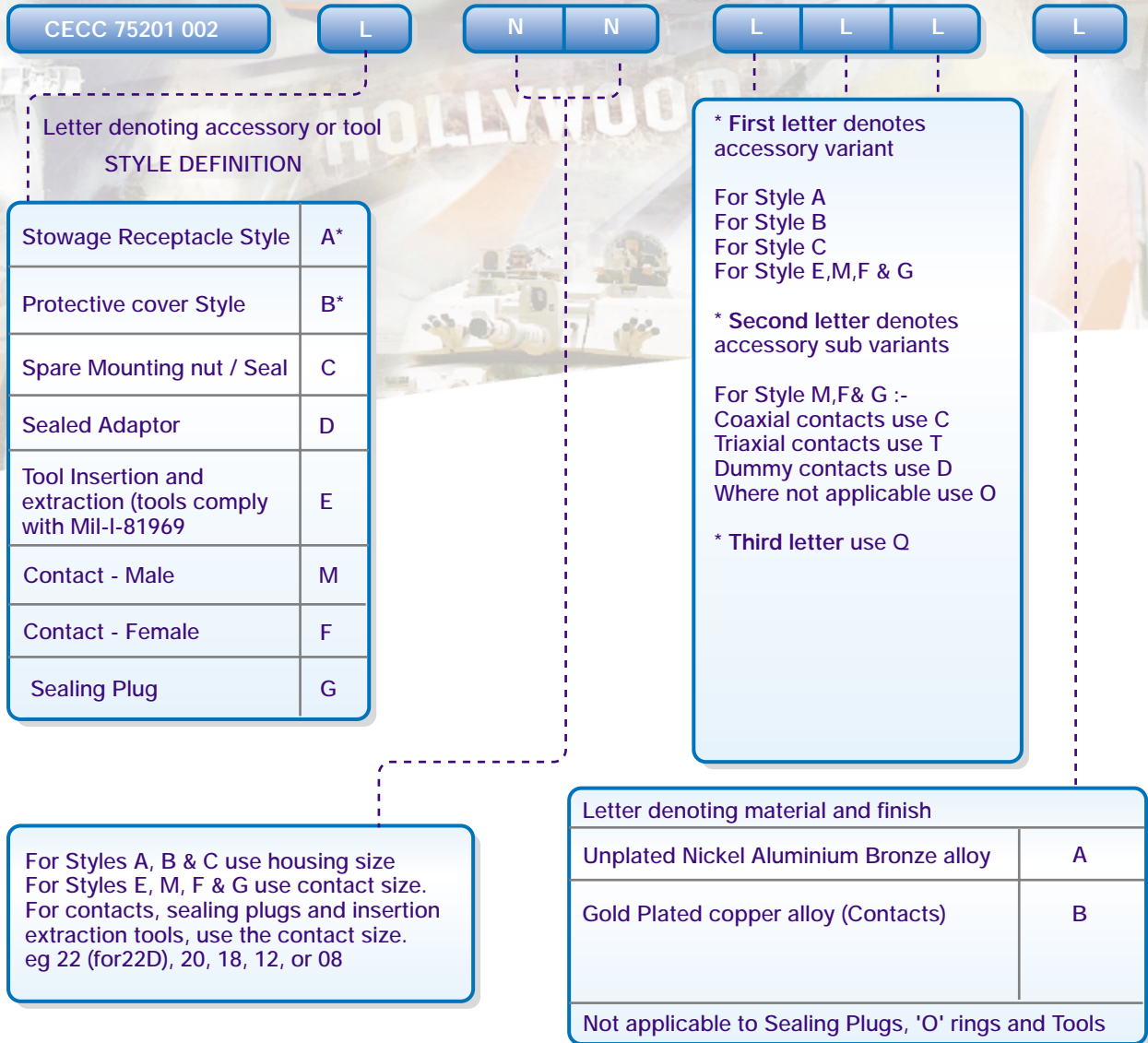

Example Type Designation:

Protective cover for fixed connector, Style B, housing (shell) size 11, Variant C, (Small termination of metal link), Sub variant 0, Obligatory third letter 0, Material - Nickel Aluminium Bronze A

Full type designation: CECC 75 201 002 B II COO A

Abbreviated: C 76 2 002 B 11 COO A

Note: Spaces are only shown above for ease of reading.

# Connector Styles & Outline Dimensions

## Free Connector with Grounding Fingers Style A

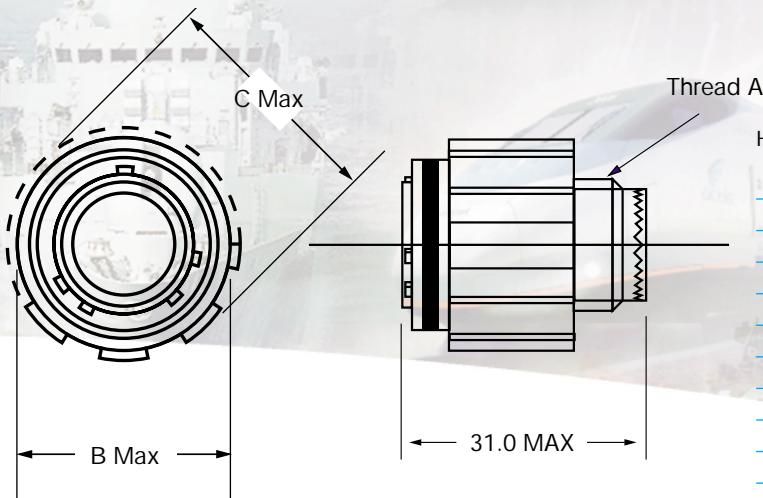

Housing (Shell) Size	Thread A	B Max	C Max	Mass Max
09	M12x1-6g	19,2	21,1	66
11	M15x1-6g	21,8	23,8	78
13	M18x1-6g	26,1	28,2	116
15	M22x1-6g	29,3	31,4	150
17	M25x1-6g	34,4	36,5	176
19	M28x1-6g	37,2	39,3	208
21	M31x1-6g	40,5	42,5	244
23	M34x1-6g	43,1	45,3	274
25	M37x1-6g	46,1	48,4	314

## Fixed Square Flange Mounting Style B

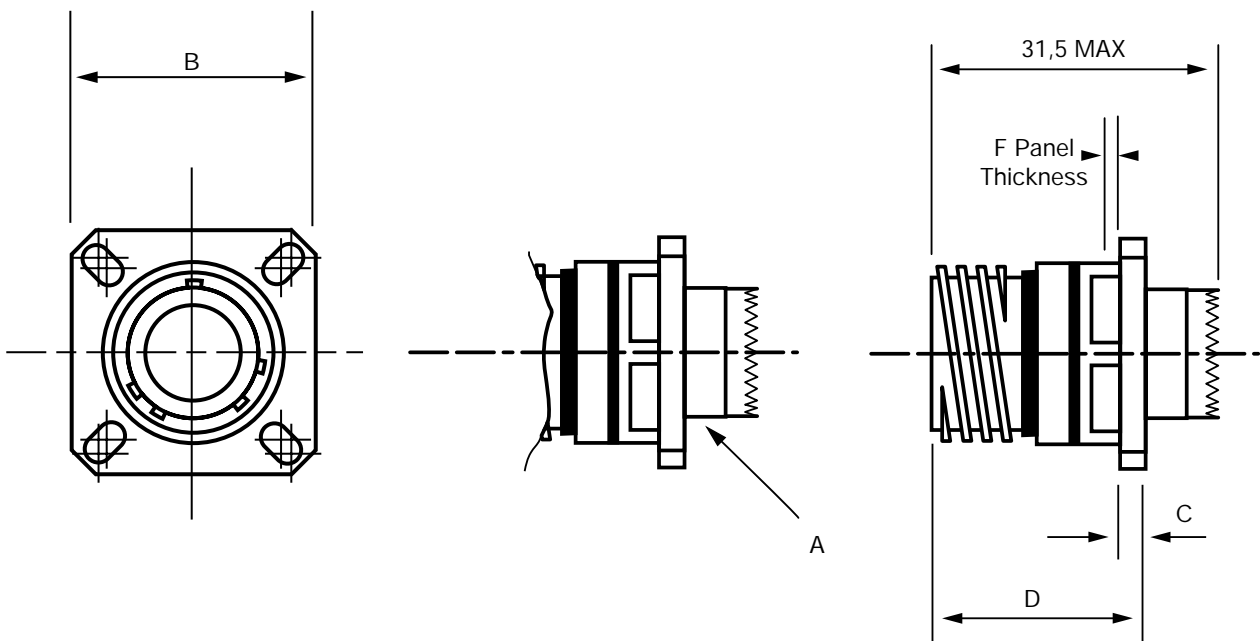

Housing (Shell) Size	Thread A	B +/-0,30	C Max	D Max	F Max	Mass Max
09	M12x1-6g	23,8	2,5	23,4	5,94	60
11	M15x1-6g	26,2	2,5	23,4	5,94	77
13	M18x1-6g	28,6	2,5	23,4	5,94	103
15	M22x1-6g	31,0	2,5	23,4	5,94	133
17	M25x1-6g	33,3	2,5	23,4	5,94	167
19	M28x1-6g	36,5	2,5	23,4	5,94	199
21	M31x1-6g	39,7	3,2	23,3	5,18	233
23	M34x1-6g	42,9	3,2	23,3	5,18	353
25	M37x1-6g	46,0	3,2	23,3	5,18	394

# Connector Styles

## Fixed Jam Nut Mounting Style C

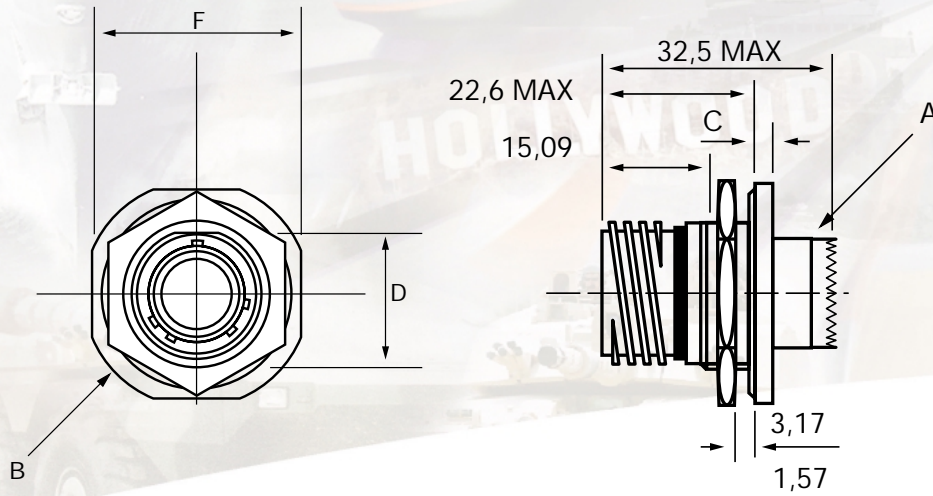

Housing (Shell) Size	Thread A	B +/-0,30	C +0,3 -0,1	D +0,10 -0,15	F +/-0,4	Mass Max
09	M12x1-6g	30,2	2,6	16,527,0	09	
11	M15x1-6g	34,9	2,6	19,07	31,8	86
13	M18x1-6g	38,1	2,6	23,82	34,9	116
15	M22x1-6g	41,3	2,6	26,97	38,1	148
17	M25x1-6g	44,5	2,6	30,15	41,3	186
19	M28x1-6g	49,2	3,4	33,32	46,0	222
21	M31x1-6g	52,4	3,4	36,50	49,2	260
23	M34x1-6g	55,6	3,4	39,67	52,4	293
25	M37x1-6g	58,7	3,4	42,85	55,6	329

## Panel Cut-Out Information

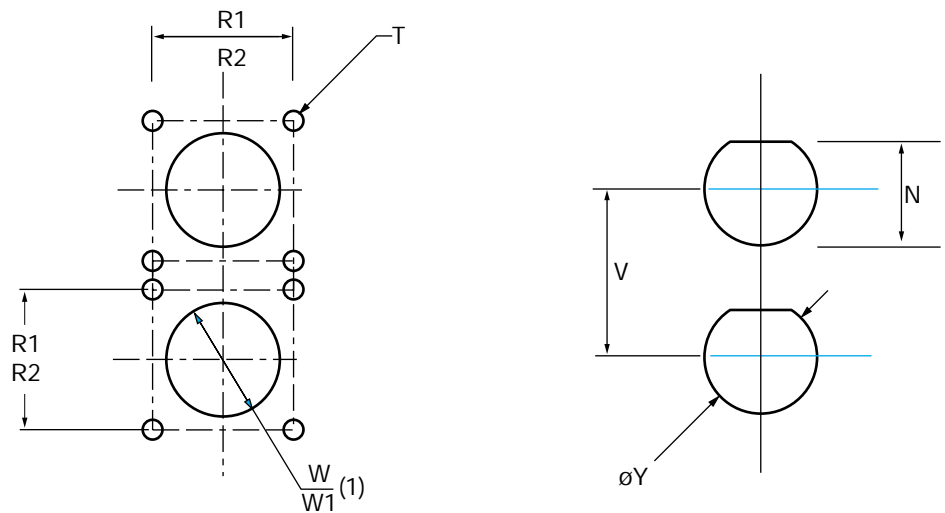

Housing (Shell) Size	N -0,25	R1 Rear Mount	R12 frnt mount	T +/-0,13	V Min	W Min rear mount	W1 Min front mount	X Min +0,25	Y
09	17,02	18,26	15,09	3,25	30,76	16,66	13,11	24,61	17,78
11	19,59	20,62	18,26	3,25	34,21	20,22	15,88	27,22	20,96
13	24,26	23,01	20,62	3,25	40,00	23,42	19,05	30,15	25,65
15	27,56	24,61	23,01	3,25	44,63	26,59	23,01	33,24	28,83
17	30,73	26,97	24,61	3,25	45,77	30,96	25,81	36,44	32,01
19	33,91	29,36	26,97	3,25	50,40	32,94	28,98	39,24	35,18
21	37,08	31,75	29,36	3,25	56,16	36,12	32,16	42,44	38,35
23	40,26	34,93	31,75	3,91	60,81	39,29	34,93	45,64	41,53
25	43,43	38,10	34,93	3,91	62,18	42,47	37,69	48,48	44,70



# Accessories

## Stowage Receptacle

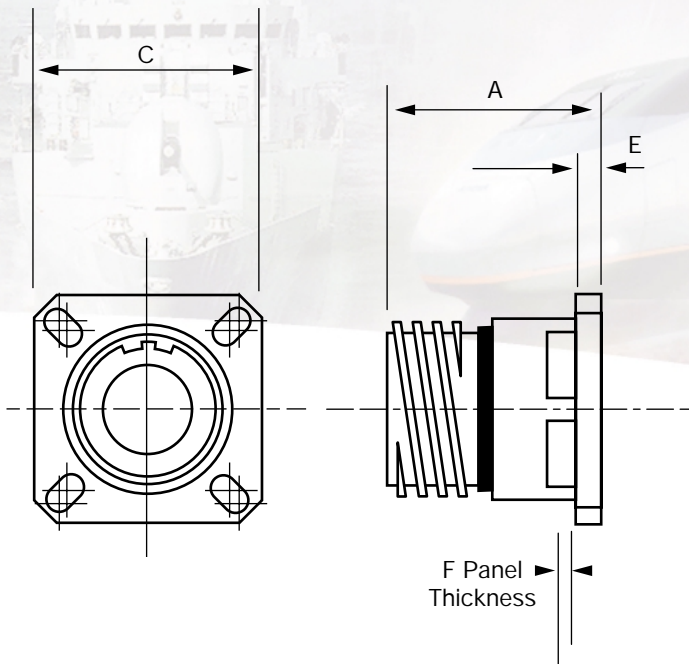

Housing (Shell) Size	A Max	C +/- 0,3	E +/-Max 0,3	Mass
09	24,2	23,8	2,5	36
11	24,2	26,2	2,5	46
13	24,2	28,6	2,5	52
15	24,2	31,0	2,5	80
17	24,2	33,3	2,5	100
19	24,2	36,5	2,5	140
21	24,1	39,7	3,2	152
25	24,1	46,0	3,2	176

## Free Protective Cap

### Termination of metal link VARIANT 'B'

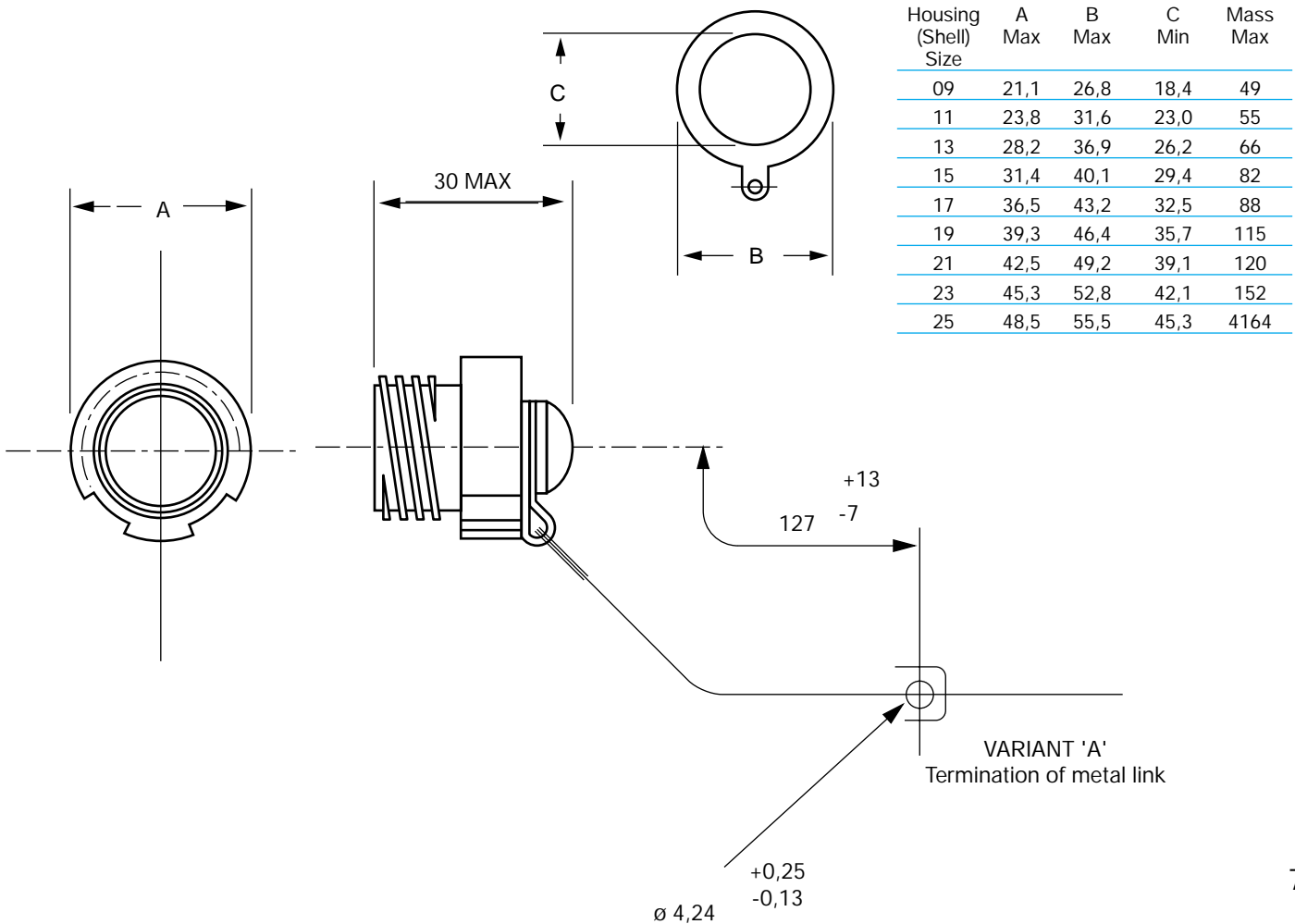

# Accessories

## Fixed protective Cap

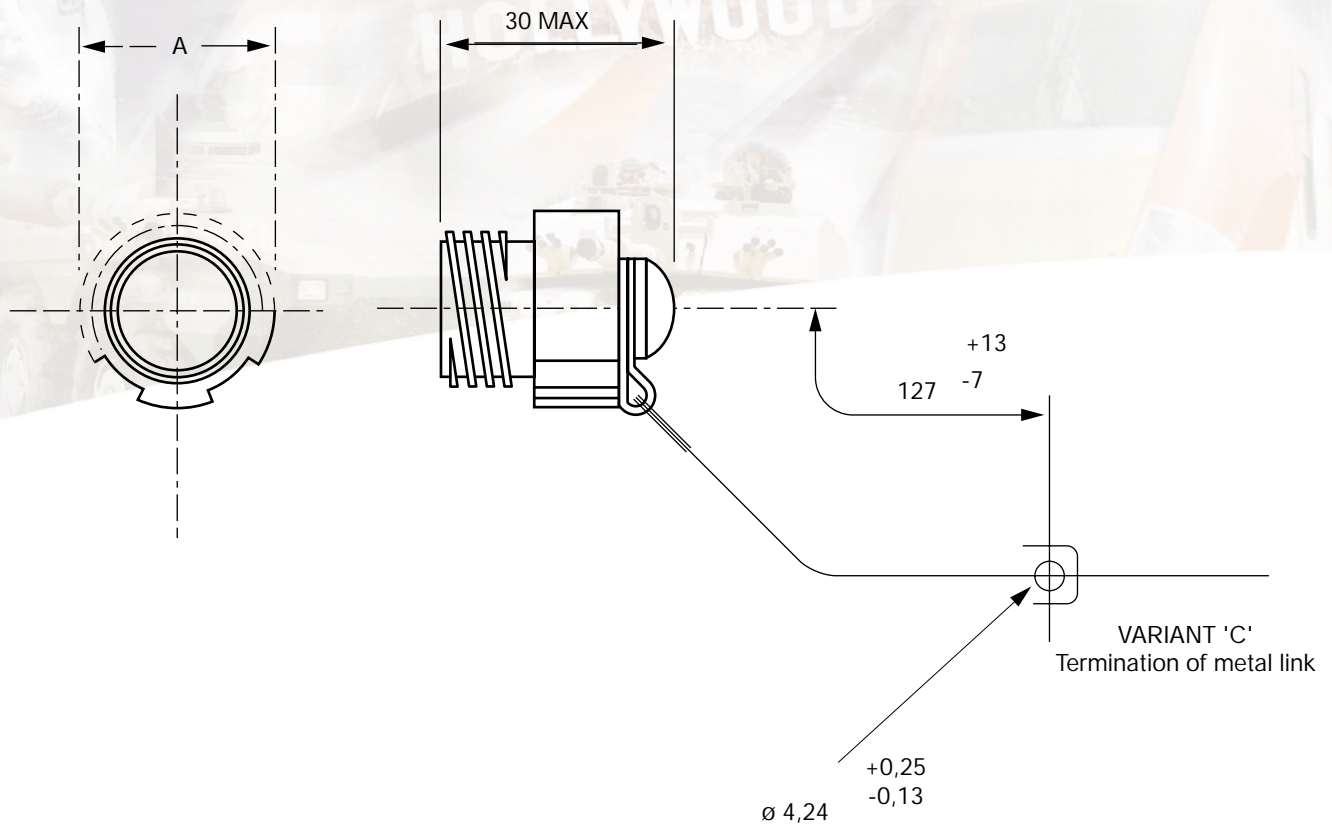

Termination of metal link  
VARIANT 'D'

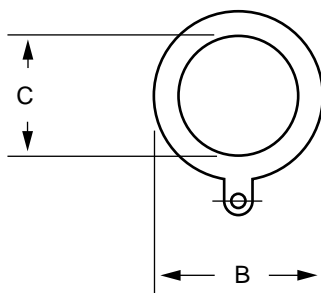

Housing (Shell) Size	A Max	B Max	C Min	Mass Max
09	21,1	26,8	18,4	49
11	23,8	31,6	23,0	55
13	28,2	36,9	26,2	66
15	31,4	40,1	29,4	82
17	36,5	43,2	32,5	88
19	39,3	46,4	35,7	115
21	42,5	49,2	39,1	120
23	45,3	52,8	42,1	152
25	48,5	55,5	45,3	164

# Contacts

## Socket Contacts

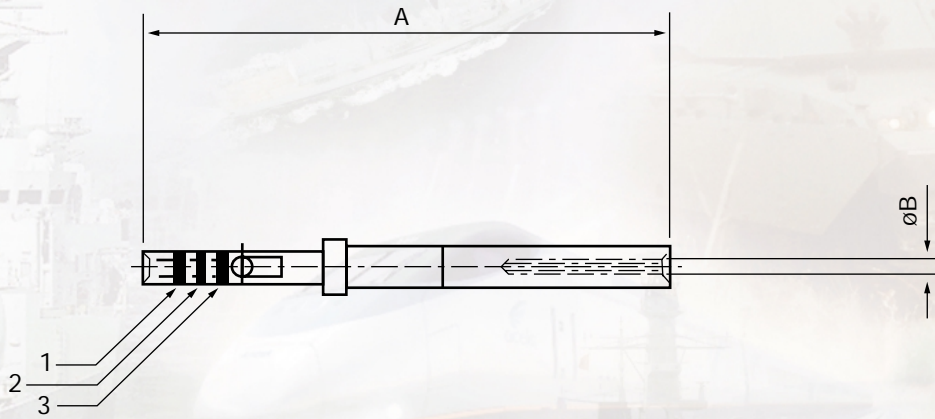

Catalogue Number	MIL-C-Part Number	Style	Barrel Size
523/4/18229/000	M 39029/58-365	Plug	12
523/4/18227/000	M 39029/58-364	Plug	16
523/4/18225/000	M 39029/58-363	Plug	20
523/4/18219/000	M 39029/58-360	Plug	22D

Contact	Size Barrel	1	Colour Code 2	3	A Max	B Max	Mass Max
22D	22D	Orange	Yellow	Grey	21,72	0,787	0,26
20	20	Orange	Green	Brown	21,72	1,054	0,45
16	16	Orange	Green	Red	21,72	1,625	0,85
12	12	Orange	Green	Orange	21,72	2,425	1,80

## Pin Contacts

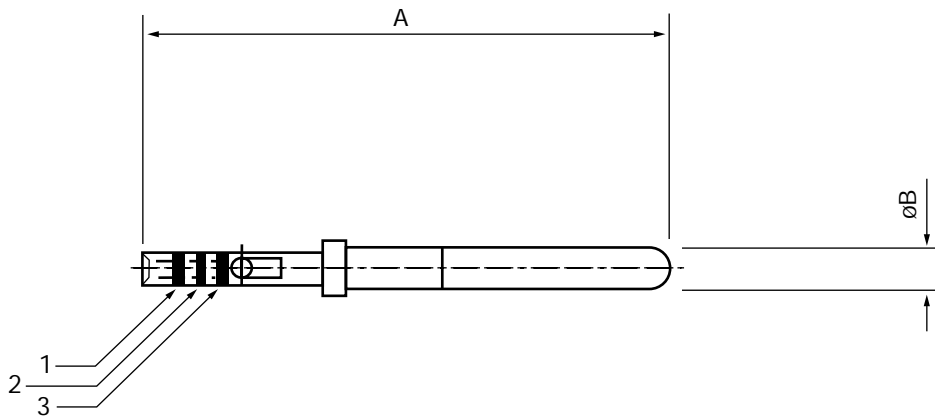

Catalogue Number	MIL-C-Part Number	Style	Barrel Size
523/4/18244/000	M 39029/56-353	Socket	12
523/4/18243/000	M 39029/58-352	Socket	16
523/4/18242/000	M 39029/56-351	Socket	20
523/4/18241/000	M 39029/58-348	Socket	22D

Size Contact	Barrel	1	Colour Code 2	3	A Max	Max	B Min	Max	Mass Max
22D	22D	Orange	Blue	Black	13,49	0,774	0,749		0,08
20	20	Orange	Blue	Orange	13,49	1,040	0,991		0,14
16	16	Orange	Blue	Yellow	13,49	1,613	1,562		0,33
12	12	Orange	Blue	Green	13,49	2,410	2,360		0,68

# Contacts

## Twinax Socket Contact - Size 8

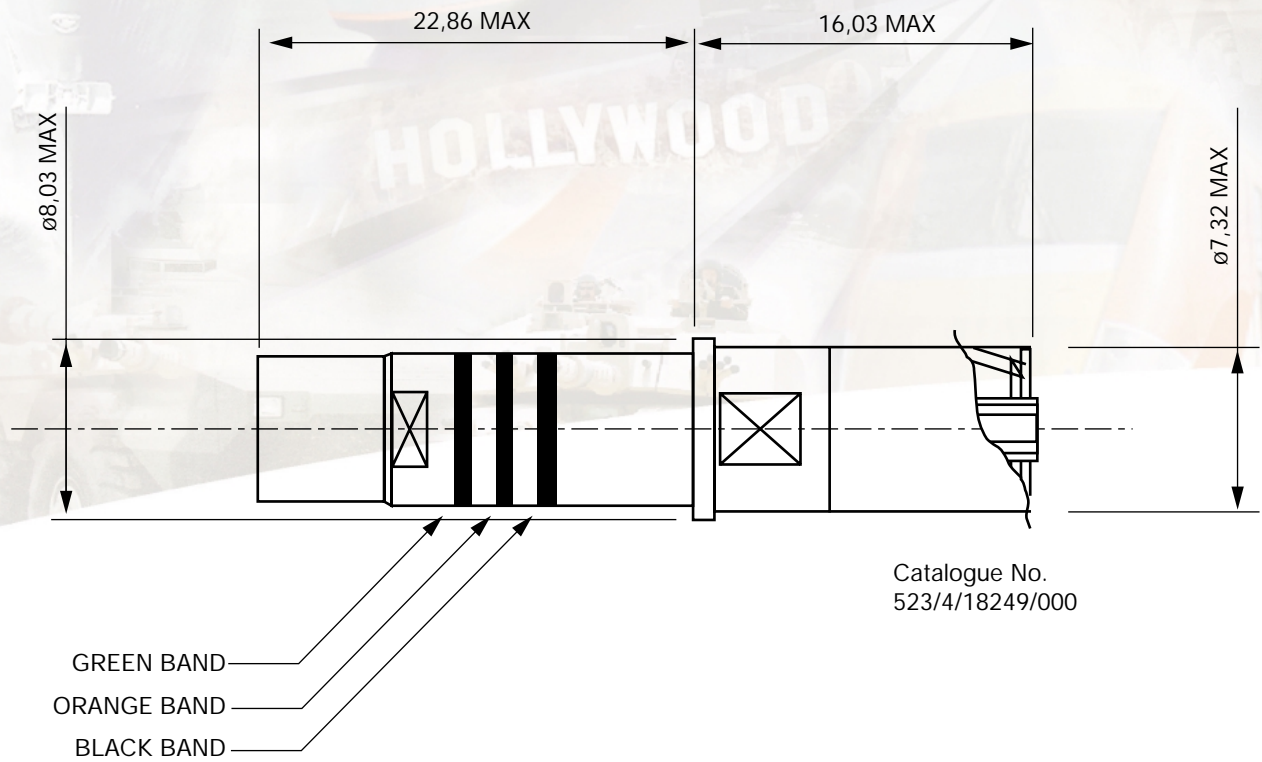

## Twinax Pin Contact - Size 8

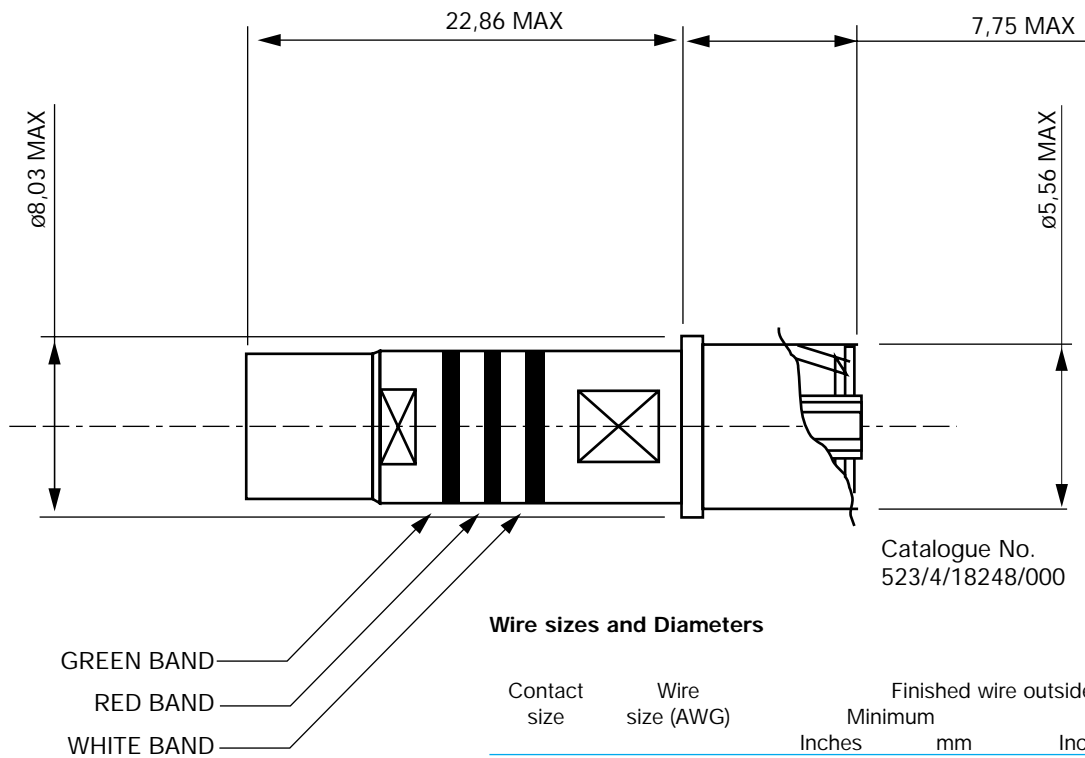

### Wire sizes and Diameters

Contact size	Wire size (AWG)	Finished wire outside dimensions			
		Minimum		Maximum	
		Inches	mm	Inches	mm
22D	28,26,24,22	.030	.076	.054	1.37
20	24,22,20	.040	1.02	.083	2.11
16	20,18,16	.065	1.65	.109	2.77
12	14,12	.097	2.46	1.42	3.61

# Contacts

## Grommet Filler Plugs

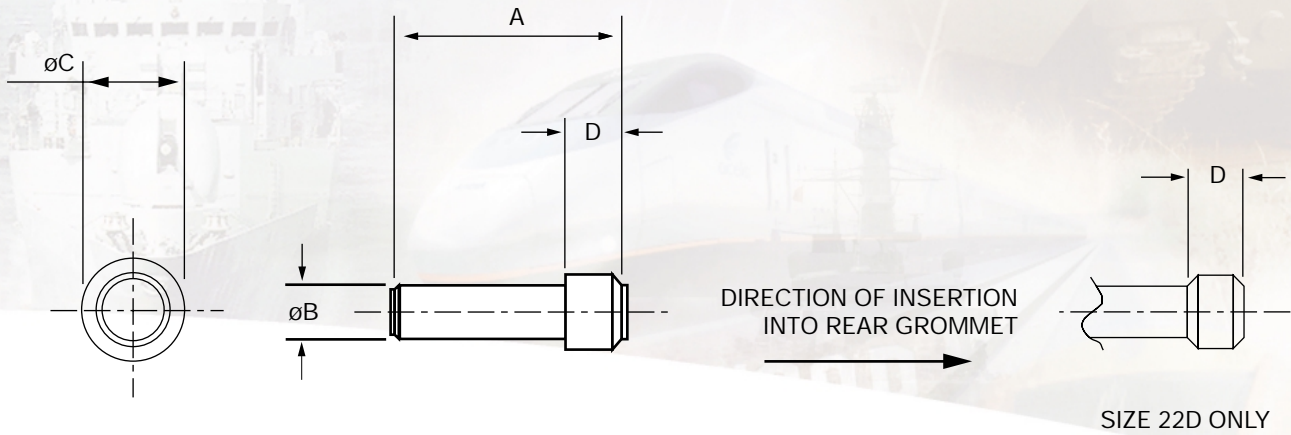

Size	Colour code	A		B		C		D		Mass Max	MS No./Size	Catalogue No.
		Max	Min	Max	Min	Max	Min	Max	Min			
22D	Black	12,70	11,13	1,14	0,89	1,72	1,48	1,32	1,06	0,30	MS27488-22	523/2/18230/004
20	Red	14,83	13,83	1,65	1,15	2,54	2,16	4,19	2,80	0,60	MS27488-20	523/2/18230/003
16	Blue	14,83	13,83	2,36	1,85	3,50	2,25	4,19	2,80	0,80	MS27488-16	523/2/18230/002
12	Yellow	14,83	13,83	3,32	2,82	4,47	4,21	4,19	2,80	1,10	MS27488-12	523/2/18230/001



# Insert Arrangements Specification

Contact Arrangement	No of contacts	Size 22D	Size 20	Size 16	Size 12	Size 8 Twinax
09-35	6	6				
09-98	3		3			
11-02	2			2		
11-35		13				
11-04	4		4			
11-05	5		5			
11-98	6		6			
11-99	7		7			
13-35	22	22				
13-04	4			4		
13-08	8		8			
13-98	10		10			
15-35	37	37				
15-05	21	16		5		
15-15	15		14	1		
15-18	18		18			
15-19	19		19			
15-97	12		8	4		
17-35	55	55				
17-06	6				6	
17-08	8			8		
17-26	26		26			
17-99	23		21	2		
19-35	66	66				
19-11	11			11		
19-28	28		26	2		
19-30	21		20	1		
19-32	32		32			
21-35	79	79				
21-11	11				11	
21-16	16			16		
21-39	39		37	2		
21-41	41		41			
21-75	4					4
23-21	21			21		
23-32	32		32			
23-35	100	100				
23-53	53		53			
23-55	55		55			
25-19	19				19	
25-20	30		10	13	4	3
25-24	24			12	12	
25-29	29			29		
25-35	128	128				
25-43	43		23	20		
25-46	46		40	4		2
25-61	61		61			

## Service Rating / Current Rating

### Contact Current Ratings

Contact size	Current (amps)
22D	3
20	6
16	10
12	16
8Twinax	N/A

### Working Voltage (RMS)

Voltage Rating M*	
Mated	Unmated
400	400
Voltage Rating I*	
Mated	Unmated
600	600
Voltage Rating II*	
Mated	Unmated
900	900
Voltage Rating	
Mated	Unmated
300	300

Air Pressure at Sea Level

### Voltage Proof (DC or AC Peak)

Voltage Rating M*	
Mated	Unmated
1300	1300
Voltage Rating I*	
Mated	Unmated
1800	1800
Voltage Rating II*	
Mated	Unmated
2300	2300
Voltage Rating	
Mated	Unmated
1000	1000

Air Pressure at Sea Level

# Insert Arrangements

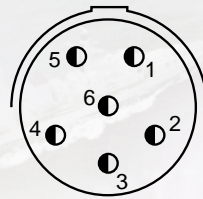

09N35  
Service M - 6 Contact size 22

Shell Size  
9

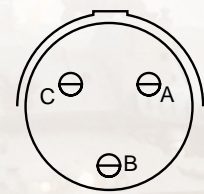

09N98  
Service I - 6 Contact size 20

Shell Size  
11



11N02  
Service I - 2 Contact size 16

Shell Size  
13

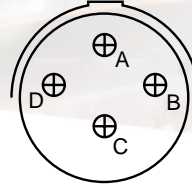

13N04  
Service M - 4 Contact size 16

Shell Size  
15

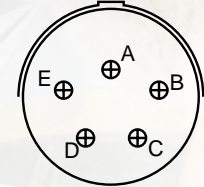

15N05  
Service I - 5 Contact size 16

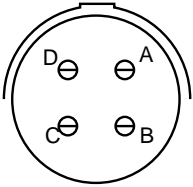

11N04  
Service I - 4 Contact size 20

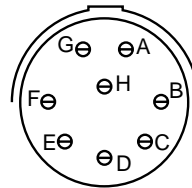

13N08  
Service I - 8 Contact size 20

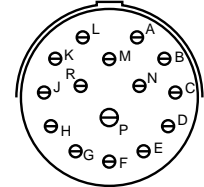

15N15 Service I  
14 Contact size 20 1 Contact size 16

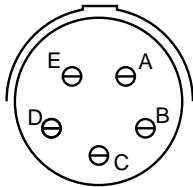

11N05  
Service I - 5 Contact size 20

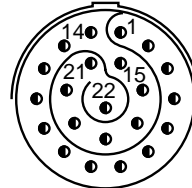

13N35  
Service M - 22 Contact size 22

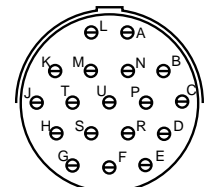

15N18  
Service I - 18 Contact size 20

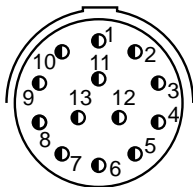

11N35  
Service I - 13 Contact size 22

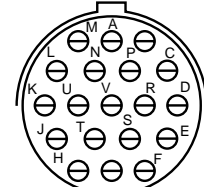

15N19  
Service I - 19 Contact size 20

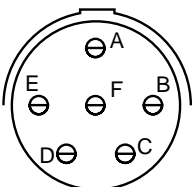

11N98  
Service I - 6 Contact size 20

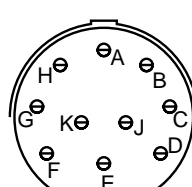

13N98  
Service I - 10 Contact size 20

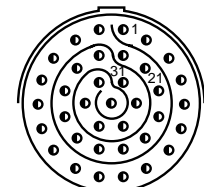

15N35  
Service M - 37 Contact size 22

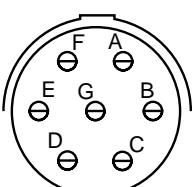

11N99  
Service I - 7 Contact size 20

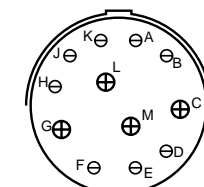

15N97 Service I  
8 Contact size 20  
4 Contact size 16

# Insert Arrangements

## Insert Arrangements

Shell Size

17

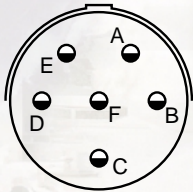

17N06  
Service I  
6 Contact size 12

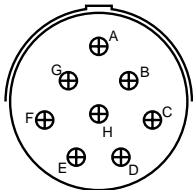

17N08  
Service II  
8 Contact size 16

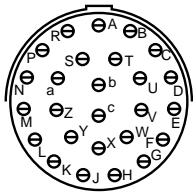

17N26  
Service I  
26 Contact size 20

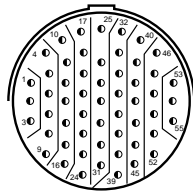

17N35  
Service M  
55 Contact size 22

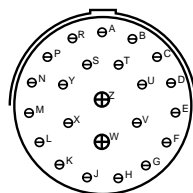

17N99  
Service I  
2 Contact size 16 21 Contact size 20

Shell Size

19

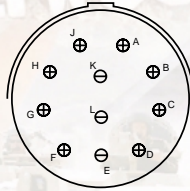

19N11  
Service I  
11 Contact size 16

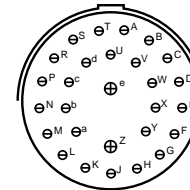

19N28  
Service I  
2 Contact size 16 26 Contact size 20

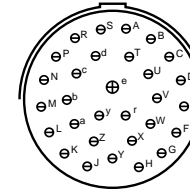

19N30  
Service I  
1 Contact size 16 29 Contact size 20

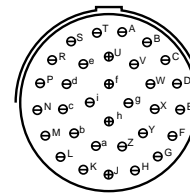

19N32  
Service M  
32 Contact size 20

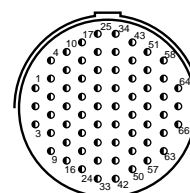

19N35  
Service M  
66 Contact size 22

Shell Size

21

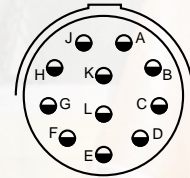

21N11  
Service I  
11 Contact size 12

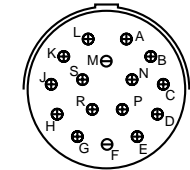

21N16  
Service II  
16 Contact size 16

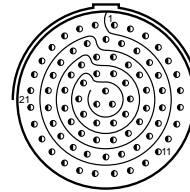

21N35  
Service M  
79 Contact size 22

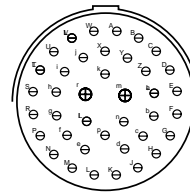

21N39 Service I  
37 Contacts size 20  
2 Contacts size 16

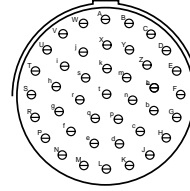

21N41  
Service I  
41 Contacts size 20

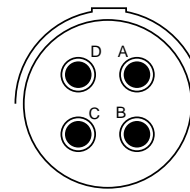

21N75  
Service M  
4 Triaxial contacts



# Insert Arrangements

## Insert Arrangements

### Shell Size

23

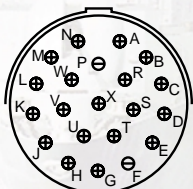

23N21  
Service II  
21 Contact size 16

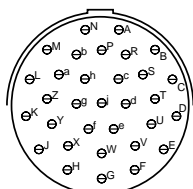

23N32  
Service I  
32 Contact size 20

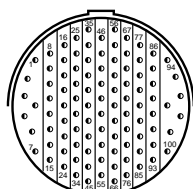

23M35  
Service M  
100 Contact size 22

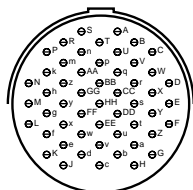

23N53  
Service I  
53 Contact size 20

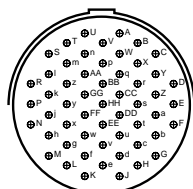

23N55  
Service I  
55 Contact size 20

### Shell Size

25

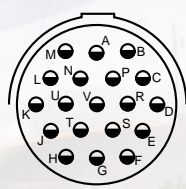

25N19  
Service I  
19 Contact size 12

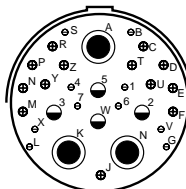

25N20 Service N  
10 Contact size 20  
13 Contact size 16  
4 Contact size 12  
3 Triaxial Contact size 8

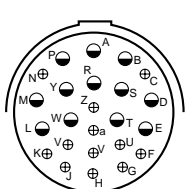

25N24 Service I  
12 Contact size 12  
12 Contact size 16

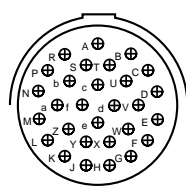

125N29  
Service I  
29 Contact size 16

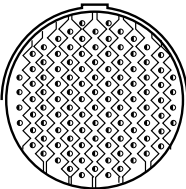

25N35  
Service M  
128 Contact size 22

### Shell Size

25 continued

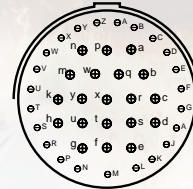

25N43  
Service I  
23 Contact size 20  
20 Contact size 16

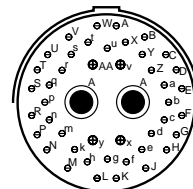

25N46  
Service I  
40 Contact size 20 4 Contact size 16  
2 Triaxial contacts size 8

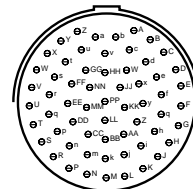

25N61  
Service I  
61 Contact size 16

# Insertion and Extraction

## Insertion and Extraction Tools

The Mk35 insertion and extraction tools have been designed of ease of use or operation and dependability. When harnesses are regularly produced using Mk35 connectors these tools are highly recommended to replace the temporary tools provided with the connector. The wire gripping feature provides for extraction, without damage to either contact, wire or the sealing features. The metal tips provide the proper balance between the hardness necessary for long usage and the resiliency needed to prevent tip breakage under constant use.



Contact Size	Contact Cat No.	Insertion Tool Cat No.
22D	523/4/18219/000 523/4/18241/000	558/I/05267/000
20	523/4/18225/000 523/I/18242/000	558/I/05253/000
16	523/4/18227/000 523/4/18243/000	558/I/05251/000
12	523/4/18229/000 523/4/18244/000	558/I/05251/001

Contact Size	Contact Cat No.	Extraction Tool Cat No.
22D	523/4/18219/000 523/4/18241/000	558/I/05254/002
20	523/4/18225/000 523/I/18242/000	558/I/05254/000
16	523/4/18227/000 523/4/18243/000	558/I/05252/000
12	523/4/18229/000 523/4/18244/000	558/I/05252/001

For size 8 tooling information please consult factory

## Crimping Tools

Tools conforming to MIL-C-22520 can be used to crimp Mk35 connector contacts.

Recommendation for the various contact types and sizes are as follows:

The above crimp tools are all available from the approved MIL. Spec. tool manufacturers.

Crimping Tool	Positioner or Turret Die	Contact Type/Size
M22520/2-01	M22520/2-09	22D, Pins
M22520/7-01	M22520/7-07	
M22520/2-01	M22520/2-07	22D, Socket
M22520/7-01	M22520/7-05	
M22520/1-01	M22520/1-04	20 Pin 20 Socket
M22520/2-01	M22520/2-10	
M22520/7-01	M22520/7-08	16 Pin 16 Socket
M22520/1-01	M22520/1-04	
M22520/7-01	M22520/7-04	12 Pin 12 Socket
M22520/1-01	M22520/1-04	

# Contact Insertion

## Tool Description

AB Connectors Insertion tools (Fig. 1) are designed to install pin and socket contacts into Mk35 Connectors designed around MIL-C-38999 contact retention system. Positive retention of contacts is accomplished by allowing the locking tabs of the contact retaining spring to engage behind the contact shoulder.

Fig. 1

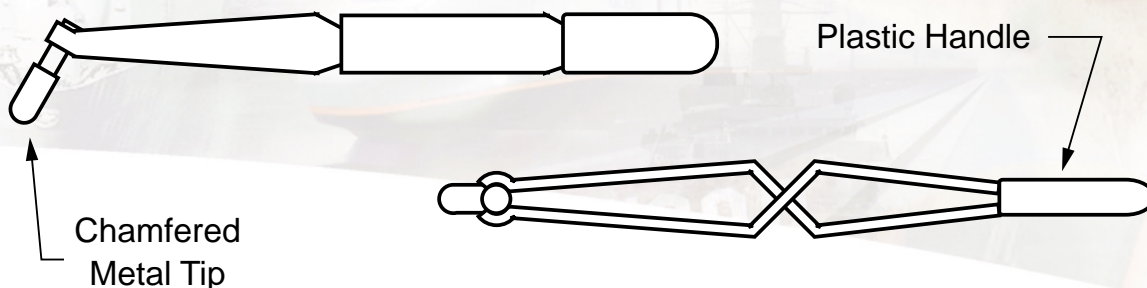

## Preparation for Insertion

1. Remove grommet nut or outlet from the connector and place over the wires to be installed.
2. Insert the crimped contact/wire assembly between the tool tips, making sure that contact shoulder is butted against tips.

Fig. 2

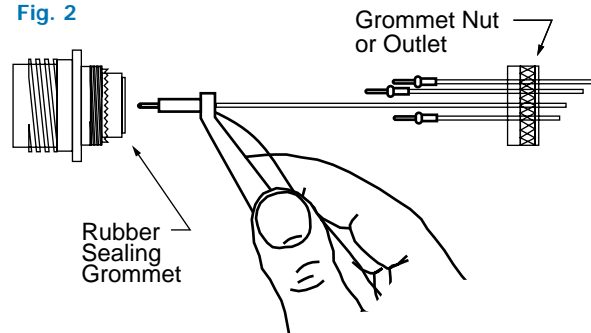

## Insertion Procedure

3. Align contact and tool with the selected hole in the connector as nearly perpendicular to the grommet face as possible.
4. Carefully push the contact into the rubber grommet hole and hard dielectric insert body until the contact shoulder stops against the insert. The contact retaining spring will then be felt or heard locking into place (Fig. 3).

Fig. 3

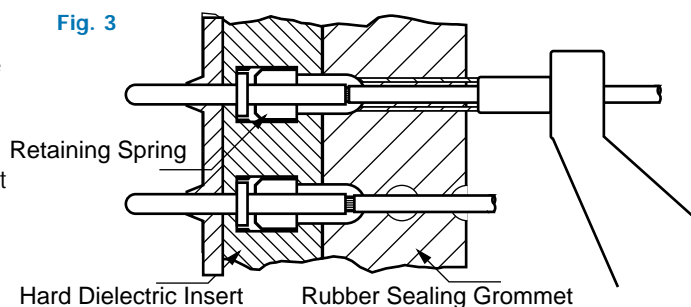

**CAUTION:** Do not squeeze the plastic tool handles while the tool tips are inside the connector. Spreading, angling, or rotating the tips can damage them and the connector.

5. Withdraw the tool completely from the connector by sliding it back along the wire insulation. Remove tool and apply a gentle pull on the wire to confirm that the contact is properly locked into place.
6. Install all other wired contacts in the same manner. Unused holes must be filled with an unwired contact followed by a sealing plug.
7. Reassemble grommet nut or outlet.

# Contact Extraction

## Tool Description

AB Connectors Extraction tools (Fig. 1 A) are designed to extract pin and socket contacts from Mk35 Connectors designed around MIL-C-38999 contact retention system. Extraction of contacts is accomplished by releasing the locking tabs of the contact retaining spring.

Fig. 1A

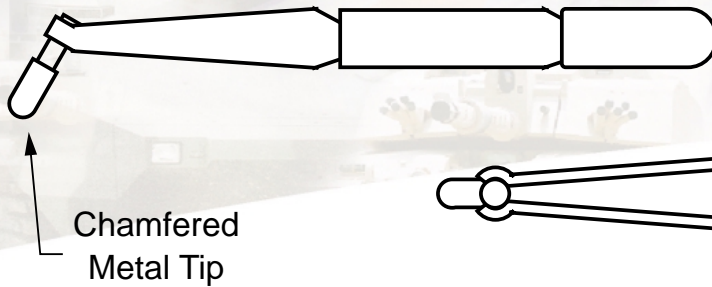
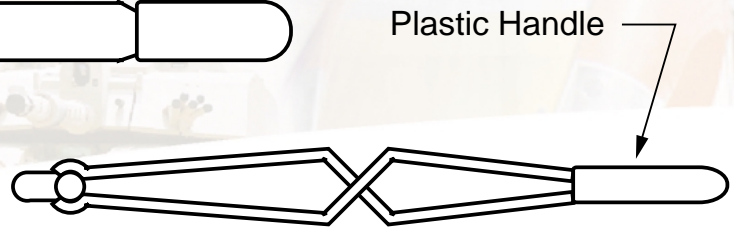

Fig. 2A



## Preparation for Extraction

1. Disassemble grommet nut or outlet from the connector, allowing it to hang on the wire bundle.
2. Insert the wire of the contact to be extracted between the tool tips.

Fig. 3A

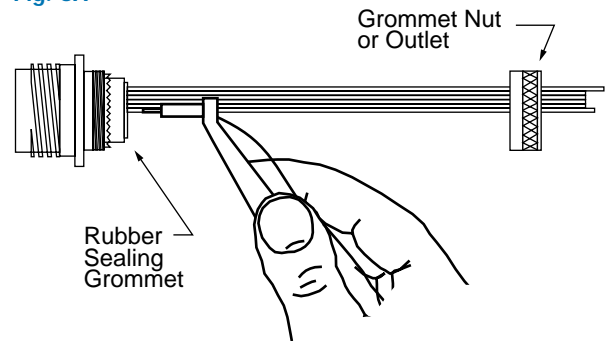

## Extraction Procedure

3. Slide the tool tips down the wire insulation into the rubber sealing grommet and hard dielectric insert body until they stop against the contact shoulder (Fig. 3A) If tips catch on wire barrel and will not enter to full depth, remove tool completely and open and close handles to realign tips.

**CAUTION:** Do not squeeze the plastic tool handles while the tool tips are inside the connector. Spreading, angling, or rotating the tips can damage them and the connector.

Fig. 4A

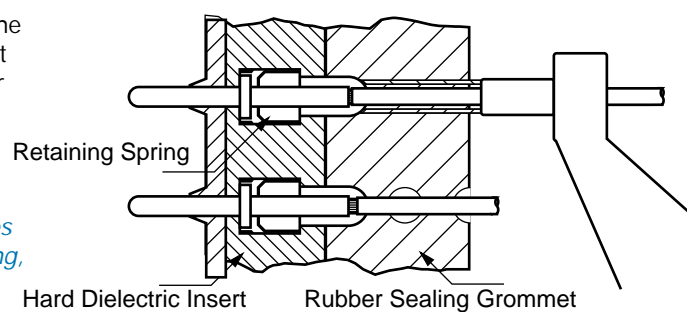

4. With the tool tips firmly butted against the contact shoulder, grip the wire insulation against the serrated tool surface without permitting any slack, and exert a light pull on the tool and wire to extract the contact (Fig. 4A) Do not increase pull if contact does not slide out easily - tool tips were not butted properly and excessive tension will damage the contact retaining spring Remove tool completely and repeat extraction procedure.
5. If wired contact is not replaced, fill unused hole with an unwired contact followed by a sealing plug.
6. Reassemble grommet nut or outlet.

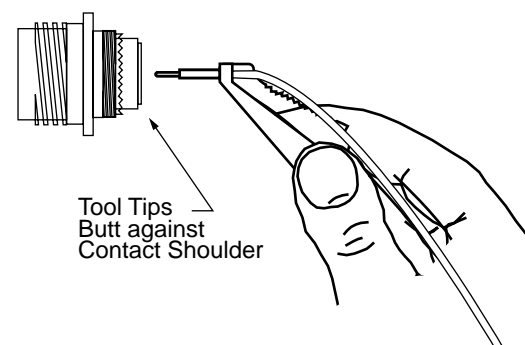



# Information about Safety

This information is to be used in conjunction with the Product Catalogue and Product Specification. Products may be safely used in the applications for which they have been designed and within the specified ratings and environments. If products are exposed to conditions outside the performance ratings or specified environments they may constitute a hazard. In particular it should be noted that:---

## 1. Material Content of Products.

Circular Connectors generally use metalwork parts made of copper, copper alloy, aluminium alloy, aluminium-bronze, phosphor-bronze or steel, which, dependant on the particular application, may be passivated and protected with cadmium or zinc plate - in conjunction with chromated or anodised surface finishes. The insulating materials can be either natural or synthetic rubber, together with plastic or glass filled plastic moulded parts. Contact materials vary with product type but are usually made of copper, copper alloy, nickel, phosphor-bronze, alumel, chromel or steel.

## 2. Electric Shock, Burns and Fire.

Hazard can occur if the product is used outside the specified parameters or if the product is damaged, wrongly wired or poorly assembled, or poorly integrated into larger equipments, or contaminated with conductive fluids. Live circuit terminations must be protected and live circuits never broken by demating products.

Hotspots may be created when resistance is increased due to damage or incorrect integration particularly soldering, crimping or loose terminations. Overheating can cause breakdown of insulation, electric shot, burns or, ultimately, fire. In the event of fire noxious and/or toxic fumes may be released and, in these circumstances, any fire involving the product should be dealt with by personnel properly equipped.

Connector products with exposed terminators or contacts should not be used on the current supply side of a circuit with exposed contacts on an unmated product. Before making a circuit live, the product and wiring should be checked to ensure that there is no damage and no electrically conducting debris present. Circuit resistance checks should also be conducted before making the circuit live. Always ensure that the correct tools, (specified by AB Connectors Ltd.) are employed for crimping and assembly and that connectors are assembled and wired by properly trained personnel.

## 3. Disposal of Products.

Products should not be burnt.

## 4. Use Transport and Storage of Products.

Care must be exercised to avoid damage to any part of the products during transporting, storage or use. The products, as manufactured, are free of sharp edges. Abnormal transit or storage conditions and abuse during installation can give rise to damage. Products should not be used in a damaged condition.

Improper storage (particularly of damaged products) can give rise to additional hazards particularly corrosion. Your attention is specifically drawn to the need of proper storage of products containing cadmium and you are advised to see the Guidance Note from the Health and Safety Executive on Cadmium - Health and Safety Precautions.

## Safety Rules

1. Ensure all conductor wires are capable of withstanding the electrical and environmental conditions of the application.
2. Always use the correct assembly tools for cables, contacts and connectors.
3. Make circuit resistance checks before making a circuit live.
4. Always protect live circuits and never demate a live connector.
5. Never use a damaged connector.
6. Never burn discarded connectors or cable.
7. IF IN DOUBT, ASK.

N.B. Additional information on the products and the materials used in them may be obtained from the Sales Department of AB Connectors Ltd.

## Shelf life for rubber components.

AB Connectors incorporate a number of rubber components within their connectors. Most rubbers change in physical properties during storage e.g. excessive hardening, softening, cracking or other surface degradation. These changes may be the result of particular factors or a combination of factors such as light, heat, humidity, oils or solvents.

With a few simple precautions the shelf life may be considerably lengthened.

The storage temperature should be between +5 and +25 degrees C. Direct contact with sources of heat such as boilers, radiators and direct sunlight should be avoided. It is advisable to cover any windows of storage rooms with a red or orange coating or screen. The relative humidity in the storeroom should be below 70%. Very moist or very dry conditions should be avoided. Condensation should not occur.

If the above recommendations are adhered to, then AB Connectors would warrant a shelf life of four years for its products.

## NB

The company reserves the right and may change or vary specification without prior written notice



## Global Presence

The world's demand for electronics is increasing as new technologies, with a higher dependence on complex components, are being adopted by a broader customer base. This growth provides TT electronics an assured future as we focus our efforts to deliver excellence in customer service and quality products to these markets.

From our strong UK base, the company has achieved truly global reach. We have established technical and manufacturing facilities in strategic countries maintaining the successful formula of close liaison with our customers in all major overseas markets.

In addition, through strategic relationships with Original Equipment Manufacturers around the world, we are now in the enviable position where we gain double benefit - from the growth in their markets and from the increase in the electronic content of end products.

Information on TT companies can be found by contacting:-

**Head Office:**

TT electronics plc  
Clive House  
12 - 18 Queens Road  
Weybridge  
Surrey  
KT13 9XB  
UK

Tel: +44(0)1932 841310  
Fax: +44(0)1932 836450

Email: [info@ttelectronics.com](mailto:info@ttelectronics.com)  
Web: [www.ttelectronics.com](http://www.ttelectronics.com)



**TT electronics**  
*AB Connectors Limited*

AB Connectors Limited  
Abercynon,  
Mountain Ash  
Rhondda Cynon Taff  
CF45 4SF, UK.  
Tel: +44(0)1443 740331  
Fax: +44(0)1443 741676  
Internet:  
<http://www.ttabconnectors.com>  
Email: [sales@ttabconnectors.com](mailto:sales@ttabconnectors.com)

AB Connectors Limited  
PO Box 2240,  
2500 Business Highway 70 East  
Smithfield,  
NC 27577, USA  
Tel: + (1)919 934 5181  
Fax: + (1)919 934 0652  
Email:  
[abconnectors@abautomotiveusa.com](mailto:abconnectors@abautomotiveusa.com)