

HGM .100" CENTERS .050" OFFSET SERIES

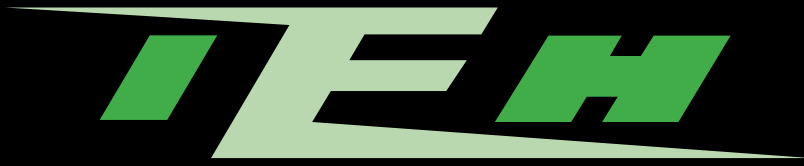

## HYPERBOLOID CONNECTORS

FOR SUPERIOR PERFORMANCE IN ALL APPLICATIONS

IEH CORPORATION ISO 9001:2000

SMALL BUSINESS-HUB-ZONE CERTIFIED

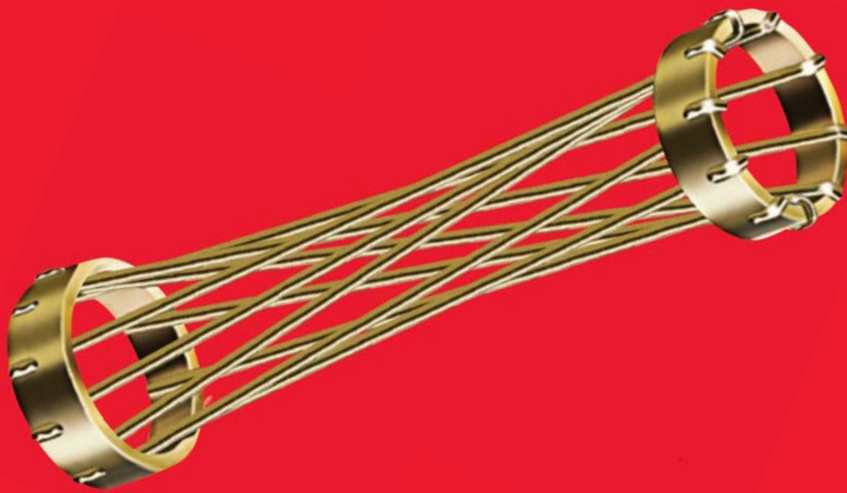

[www.iehcorp.com](http://www.iehcorp.com)

## **CONTENTS**

### **HGM SERIES - .100 X .100 CONNECTORS**

**PAGE**

- 4** Introduction
- 5** Specifications
- 6** Ordering Chart - 2 Row

---

#### **2 ROW 010-070**

- 7** FAE9, FVEA - Receptacle, Stacking
- 8** FBE, FDE, FSE, FWE - Receptacle, Straight (Flex Cable, Dip Solder, Solder Cup, Wire Wrap)
- 9** FEE - Receptacle, Right Angle (Dip Solder)
- 10** FRE - Receptacle, Surface Mount
- 11** FVE - Receptacle, Compliant
- 12** SAE9, SVEA - Receptacle, Plug Pattern, Stacking
- 13** SBE, SDE, SSE, SWE - Receptacle, Plug Pattern, Straight (Flex Cable, Dip Solder, Solder Cup, Wire Wrap)
- 14** SEE - Receptacle, Plug Pattern, Right Angle (Dip Solder)
- 15** SRE - Receptacle, Plug Pattern, Surface Mount
- 16** SVE - Receptacle, Plug Pattern, Compliant
- 17** MAE9, MVEA - Plug, Receptacle Pattern, Stacking
- 18** MBE, MDE, MSE, MWE - Plug, Receptacle Pattern, Straight (Flex Cable, Dip Solder, Solder Cup, Wire Wrap)
- 19** MEE, MXE - Plug, Right Angle (Dip Solder, Solder Cup)
- 20** MLE - Plug, Right Angle, Compliant
- 21** MRE - Plug, Receptacle Pattern, Surface Mount
- 22** MVE - Plug, Receptacle Pattern, Compliant
- 23** PAE9, PVEA - Plug, Stacking
- 24** PBE, PDE, PSE, PWE - Plug, Straight (Flex Cable, Dip Solder, Solder Cup, Wire Wrap)
- 25** PRE - Plug, Surface Mount
- 26** PVE - Plug, Compliant

---

#### **2 ROW 090**

- 27** FBE, FDE, FSE, FWE - Receptacle, Straight (Flex Cable, Dip Solder, Solder Cup, Wire Wrap)
- 28** FEE - Receptacle, Right Angle (Dip Solder)
- 29** FRE - Receptacle, Surface Mount
- 30** FVE - Receptacle, Compliant
- 31** MEE - Plug, Right Angle (Dip Solder)
- 32** RBE, RDE, RSE, RWE - Plug, Straight (Flex Cable, Dip Solder, Solder Cup, Wire Wrap)

---

#### **2 ROW 100**

- 33** HGM100 FBE, FDE, FSE, FWE - Receptacle, Straight (Flex Cable, Dip Solder, Solder Cup, Wire Wrap)
- 34** HGM100 FEE - Receptacle, Right Angle (Dip Solder)
- 35** HGM100 FRE - Receptacle, Surface Mount
- 36** HGM100 FVE - Receptacle, Compliant
- 37** HGM100 SBE, SDE, SSE, SWE - Receptacle, Plug Pattern, Straight (Flex Cable, Dip Solder, Solder Cup, Wire Wrap)
- 38** HGM100 SVE - Receptacle, Plug Pattern, Compliant
- 39** HGM100 MBE, MDE, MSE, MWE - Plug, Receptacle Pattern, Straight (Flex Cable, Dip Solder, Solder Cup, Wire Wrap)
- 40** HGM100 MEE - Plug, Right Angle (Dip Solder)
- 41** HGM100 PBE, PDE, PSE, PWE - Plug, Straight (Flex Cable, Dip Solder, Solder Cup, Wire Wrap)
- 42** HGM100 PVE - Plug, Compliant

## **CONTENTS**

### **HGM SERIES - .100 X .100 CONNECTORS**

**PAGE**

---

**2 ROW 120**

---

- 43** FBE, FDE, FSE, FWE - Receptacle, Straight (Flex Cable, Dip Solder, Solder Cup, Wire Wrap)
- 44** FEE - Receptacle, Right Angle (Dip Solder)
- 45** FRE - Receptacle, Surface Mount
- 46** FVE - Receptacle, Compliant
- 47** MEE - Plug, Right Angle (Dip Solder)
- 48** RBE, RDE, RSE, RWE - Plug, Straight (Flex Cable, Dip Solder, Solder Cup, Wire Wrap)
  
- 49** Ordering Chart - 3 Row

---

**3 ROW 050-104**

---

- 50** FAE9, FVEA - Receptacle, Stacking
- 51** FBE, FDE, FSE, FWE - Receptacle, Straight (Flex Cable, Dip Solder, Solder Cup, Wire Wrap)
- 52** FEE - Receptacle, Right Angle (Dip Solder)
- 53** FVE - Receptacle, Compliant
- 54** MAE9, MVEA - Plug, Stacking
- 55** MBE, MDE, MSE, MWE - Plug, Straight (Flex Cable, Dip Solder, Solder Cup, Wire Wrap)
- 56** MEE, MLE, MXE - Plug, Right Angle (Dip Solder, Compliant, Solder Cup)
- 57** MVE - Plug, Compliant

---

**3 ROW 122**

---

- 58** FAE9, FVEA - Receptacle, Stacking
- 59** FBE, FDE, FSE, FWE - Receptacle, Straight (Flex Cable, Dip Solder, Solder Cup, Wire Wrap)
- 60** FEE - Receptacle, Right Angle (Dip Solder)
- 61** FVE - Receptacle, Compliant
- 62** MAE9, MVEA - Plug, Stacking
- 63** MBE, MDE, MSE, MWE - Plug, Straight (Flex Cable, Dip Solder, Solder Cup, Wire Wrap)
- 64** MEE, MLE, MXE - Plug, Right Angle (Dip Solder, Compliant, Solder Cup)
- 65** MVE - Plug, Compliant

---

**3 ROW 160**

---

- 66** FAE9, FVEA - Receptacle, Stacking
- 67** FBE, FDE, FSE, FWE - Receptacle, Straight (Flex Cable, Dip Solder, Solder Cup, Wire Wrap)
- 68** FEE - Receptacle, Right Angle (Dip Solder)
- 69** FVE - Receptacle, Compliant
- 70** MAE9, MVEA - Plug, Stacking
- 71** MBE, MDE, MSE, MWE - Plug, Straight (Flex Cable, Dip Solder, Solder Cup, Wire Wrap)
- 72** MEE, MLE, MXE - Plug, Right Angle (Dip Solder, Compliant, Solder Cup)
- 73** MVE - Plug, Compliant

## **CONTENTS**

### **HGM SERIES - .100 X .100 CONNECTORS**

**PAGE**

---

**3 ROW 208**

---

<b>74</b>	FAE9, FVEA - Receptacle, Stacking
<b>75</b>	FBE, FDE, FSE, FWE - Receptacle, Straight (Flex Cable, Dip Solder, Solder Cup, Wire Wrap)
<b>76</b>	FEE - Receptacle, Right Angle (Dip Solder)
<b>77</b>	FVE - Receptacle, Compliant
<b>78</b>	MAE9, MVEA - Plug, Stacking
<b>79</b>	MBE, MDE, MSE, MWE - Plug, Straight (Flex Cable, Dip Solder, Solder Cup, Wire Wrap)
<b>80</b>	MEE, MLE, MXE - Plug, Right Angle (Dip Solder, Compliant, Solder Cup)
<b>81</b>	MVE - Plug, Compliant

---

**SPECIALTY - 4 ROW**

---

<b>82</b>	HGM 122 FBE, FDE, FSE, FWE
<b>83</b>	HGM 122 FEE
<b>84</b>	HGM 122 MBE, MDE, MSE, MWE
<b>85</b>	HGM 122 MEE

---

**APPENDIX**

---

<b>A1</b>	Termination Styles - 2 Row - Receptacle
<b>A2</b>	Termination Styles - 2 Row - Plug, Right Angle
<b>A3</b>	Termination Styles - 2 Row - Plug, Straight
<b>A4</b>	Termination Styles - 2 Row - Plug, Straight, High Profile
<b>A5</b>	Termination Styles - 3 Row - Receptacle
<b>A6</b>	Termination Styles - 3 Row - Plug, Right Angle
<b>A7</b>	Termination Styles - 3 Row - Plug, Straight
<b>A8</b>	Hardware Styles - 2 & 3 Row
<b>A9</b>	Polarization Chart - 2 & 3 Row
<b>A10</b>	PWB Pattern - 2 Row - 010-070, Receptacle Pattern
<b>A11</b>	PWB Pattern - 2 Row - 010-070, Plug Pattern
<b>A12</b>	PWB Pattern - 2 Row - 090, Receptacle Pattern
<b>A13</b>	PWB Pattern - 2 Row - 090, Plug Pattern
<b>A14</b>	PWB Pattern - 2 Row - 100, Receptacle Pattern
<b>A15</b>	PWB Pattern - 2 Row - 100, Plug Pattern
<b>A16</b>	PWB Pattern - 2 Row - 120, Receptacle Pattern
<b>A17</b>	PWB Pattern - 2 Row - 120, Plug Pattern
<b>A18</b>	PWB Pattern - 3 Row - 050-104
<b>A19</b>	PWB Pattern - 3 Row - 122
<b>A20</b>	PWB Pattern - 3 Row - 160
<b>A21</b>	PWB Pattern - 3 Row - 208

The HYPERBOLOID contact is an advanced design that satisfies performance requirements previously considered impossible. Radically different in concept, it is used in connectors having the highest standards of performance. The distinguishing feature of the HYPERBOLOID socket is the hyper-boloid-shaped sleeve formed by straight wires strung at an angle to the longitudinal axis. Viewed from the side, you see a curve defined by a series of apparent short straight line segments which are tangent lines to points along a hyperbolic curve. This geometry provides for a design which has a decreasing circumscribed circle when viewed from the entry. It begins larger than the pin acceptance diameter and is less than this same diameter at the center. When the pin is inserted into this sleeve, the wires stretch, well within elastic limits, to accommodate it. In so doing, the wires wrap themselves around the pin providing a number of continuous line contact paths. The illustration below will assist in visualization.

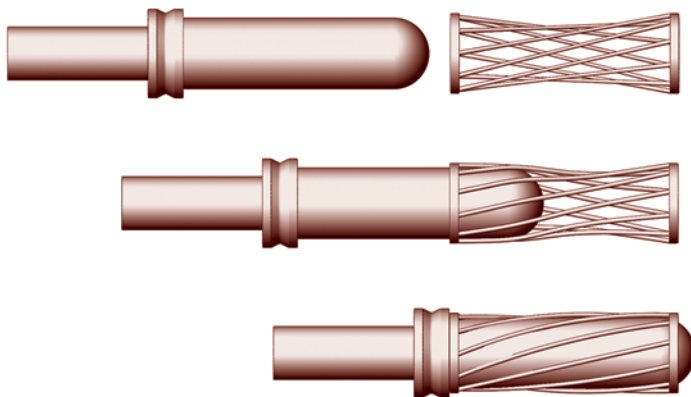

The actual physical construction of the contact involves several components. The wires are strung on an internal wire carrier (inner sleeve) which is subsequently capped or enclosed by a front outer ring (front sleeve) and rear ring which includes the termination configuration (terminal). All components to the assembly are completely finished with the specified electroplating prior to assembly. The wires are continuous process plated on reel before use. In this manner, interface finish requirements can be controlled very closely without the common problems of gradient, shadow, or other finish imperfections often appearing in alternative designs. Very often, this processing feature permits the specifier to reduce precious metal content with resultant savings. Joints are calculated interference fits, insuring gas tight interfaces between all elements of the HYPERBOLOID construction. An exploded view is provided next.

The unique geometry, precision processing, and careful attention to quality result in a highly desirable contact design which provides:

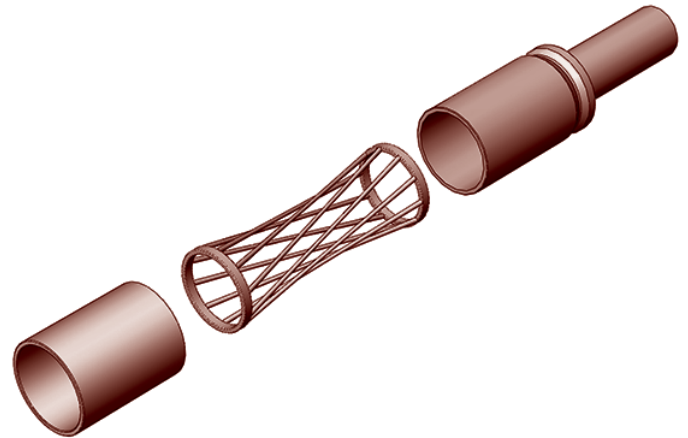

- **VLIF (Very Low Insertion Force):** Common sizes #22 and less average under one ounce per contact.
- **Extraordinary Resistance to Shock & Vibration:** Tests exceeding 300 g's without discontinuity.
- **Duty Cycle Exceeding 100,000 Mate/Demate:** The burnishing action of the wires on the pin surface is non-destructive. Unlike the "plow" and scrape action of common designs, HYPERBOLOID's gentle mating action enhances life.
- **Low, Low Contact Resistance:** The multiplicity of line contact, as opposed to point contact in other designs, provides an excellent interface exhibiting low contact resistance (often less than 1/2 of MIL spec. allowances). This characteristic also provides for a cooler running contact under load.
- **Improved Current Carrying Capacity:** The low contact resistance gives a lower °C rise from ambient under load. This feature often allows the user to operate the same size contact under higher load.
- **Highest Reliability:** In use for over 40 years under the most demanding conditions HYPERBOLOID has proven itself to be the leading design for integrity and reliability. On space platforms, ships and boats at sea, land vehicles, fighter and transport aircraft, missiles, torpedoes, medical and transplant electronics, industrial and environmental controls, rail, construction, ATE and test equipment, PGA sockets, test interface stations, and other applications, HYPERBOLOID has lived up to its promise of the highest reliability connector available.

## SPECIFICATIONS

### MATERIALS:

Pin Contacts:	PhBr per ASTM B139, BeCu per ASTM B196 or B197, or Cu alloy
Pin Diameter:	.030" (.76mm)
Socket Contacts:	
Contact Wires:	BeCu per ASTM B196, or B197
Termination:	PhBr per ASTM B139 or Cu alloy
Support Elements:	Cu alloy
SMT Leads:	PhBr per ASTM B139
Hardware:	Corrosion resistant steel per ASTM A582 ('D' shaped guide receptacles are BeCu per ASTM B196 or B197) or Cu alloy
Insulator:	Modified polyphenylene sulfide per MIL-M-24519, Type GST-40F Diallyl Phthalate per ASTM D5948 (Not for New Designs)
Pin Shields:	Aluminum 5052-H32 per QQ-A-250/8

### FINISHES:

Pin Contacts:	Gold per ASTM B488 Type II, Class 1.27, Code C over Nickel, 0.000050 min., per MIL-DTL-55302 over Copper per SAE AMS 2418 or ASTM B734
Socket Contacts:	
Contact Wires:	Gold per ASTM B488 Type II, Class 1.27, Code C over Nickel, 0.000050 min., per MIL-DTL-55302 over Copper per SAE AMS 2418 or ASTM B734
Termination:	Gold per ASTM B488, Class 0.50, Grade C over Nickel, 0.000050 min., per MIL-DTL-55302 over Copper per SAE AMS 2418 or ASTM B734 or solder dip over Nickel, 0.000050 min., per MIL-DTL-55302 over Copper per SAE AMS 2418 or ASTM B734
Support Elements:	Nickel, 0.000050 min., over Copper per SAE AMS 2418 or ASTM B734
SMT Leads:	Tin/Lead per SAE-AMS-P-81728
Hardware:	Passivate per SAE-AMS2700 except BeCu hardware to be Nickel plate, 0.000050 min.
Pin Shields:	Black Anodize per MIL-A-8625, Type II, Class 2

### PERFORMANCE:

Current Rating:	5* amp continuous (higher ratings may be supported-contact factory)
Insulation Resistance:	5000 megaohms min. – EIA-364-21 & MIL-DTL-55302 (par. 4.5.8)
Contact Resistance:	8 milliohms max, - EIA-364-06 & MIL-DTL-55302 (par. 4.5.5)
Test Voltage (DWV):	1000 VAC RMS @ sea level - EIA-364-20 & MIL-DTL-55302 (par. 4.5.7.1) 300VAC RMS @ 70,000 ft.
Temperature:	-65°C to +125°C (-86°F to +257°F)
Mating Force:	0.15 lbs. x number of contacts, max. - MIL-STD-55302 (par. 4.5.4)
De-mating Force:	0.03 lbs. x number of contacts, min. - MIL-STD-55302 (par. 4.5.4)
Contact Life:	100,000 mating cycles – Exceeds MIL-DTL-55302 (par. 4.5.9)
Solderability:	IPC/EIA J-STD-002, Category 3
Humidity:	IAW EIA-364-31, Method IV, except 7A & 7B (not required)
Vibration:	IAW EIA-364-28 & MIL-DTL-55302 (par. 4.5.10)
Shock:	IAW EIA-364-27 & MIL-DTL-55302 (par. 4.5.14)
Salt Spray:	IAW EIA-364-26 & MIL-DTL-55302 (par. 4.5.11)
Temperature Cycling:	IAW EIA-364-32 & MIL-DTL-55302 (par. 4.5.13)

### DIMENSIONS:

Catalog product dimensions are nominal. For linear and positional tolerances, contact factory.

\* Ampacity ratings shown are derated in accordance with the published military specifications. For stand-alone, full service ratings, supported by test data, please refer to IEH's Contacts Catalog, or contact the factory.

All information contained herein is believed to be reliable as of the date of publication, but is subject to change without notice. Current product drawings and specifications are available upon request from IEH.

IEH warrants its products to be free of defects affecting normal use. If any shipment is found to be defective we will accept return for repair or replacement at our option within one year of shipment. IEH is not responsible for incidental or consequential damages arising out of the use of our products.

**ORDERING CHART  
2-ROW**

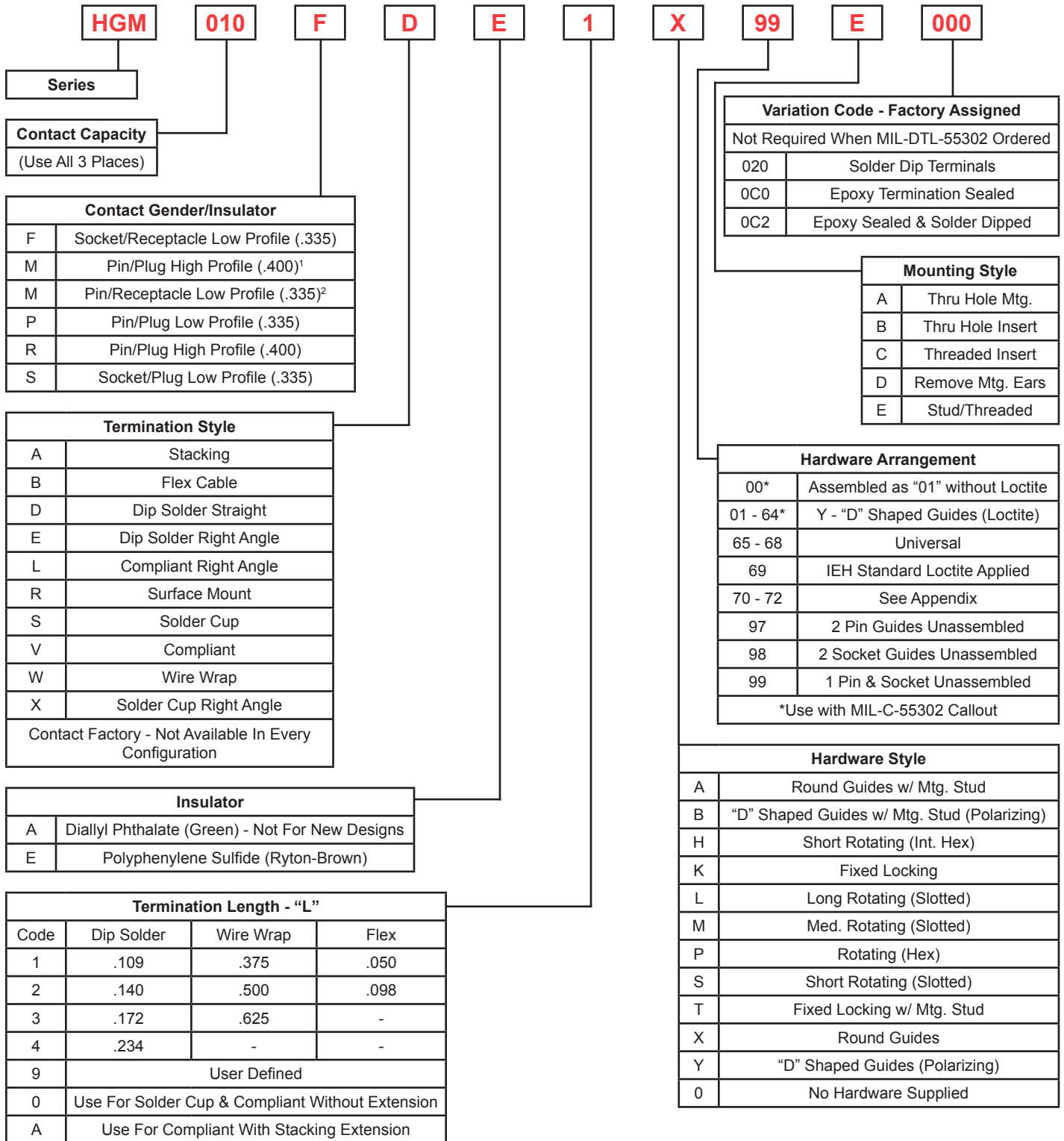

**HGM**  
Series

**010**  
Contact Capacity  
(Use All 3 Places)

Contact Gender/Insulator	
F	Socket/Receptacle Low Profile (.335)
M	Pin/Plug High Profile (.400) <sup>1</sup>
M	Pin/Receptacle Low Profile (.335) <sup>2</sup>
P	Pin/Plug Low Profile (.335)
R	Pin/Plug High Profile (.400)
S	Socket/Plug Low Profile (.335)

Termination Style	
A	Stacking
B	Flex Cable
D	Dip Solder Straight
E	Dip Solder Right Angle
L	Compliant Right Angle
R	Surface Mount
S	Solder Cup
V	Compliant
W	Wire Wrap
X	Solder Cup Right Angle
Contact Factory - Not Available In Every Configuration	

Insulator	
A	Diallyl Phthalate (Green) - Not For New Designs
E	Polyphenylene Sulfide (Ryton-Brown)

Termination Length - "L"			
Code	Dip Solder	Wire Wrap	Flex
1	.109	.375	.050
2	.140	.500	.098
3	.172	.625	-
4	.234	-	-
9	User Defined		
0	Use For Solder Cup & Compliant Without Extension		
A	Use For Compliant With Stacking Extension		

Variation Code - Factory Assigned	
Not Required When MIL-DTL-55302 Ordered	
020	Solder Dip Terminals
0C0	Epoxy Termination Sealed
0C2	Epoxy Sealed & Solder Dipped

Mounting Style	
A	Thru Hole Mtg.
B	Thru Hole Insert
C	Threaded Insert
D	Remove Mtg. Ears
E	Stud/Threaded

Hardware Arrangement	
00*	Assembled as "01" without Loctite
01 - 64*	Y - "D" Shaped Guides (Loctite)
65 - 68	Universal
69	IEH Standard Loctite Applied
70 - 72	See Appendix
97	2 Pin Guides Unassembled
98	2 Socket Guides Unassembled
99	1 Pin & Socket Unassembled
*Use with MIL-C-55302 Callout	

Hardware Style	
A	Round Guides w/ Mtg. Stud
B	"D" Shaped Guides w/ Mtg. Stud (Polarizing)
H	Short Rotating (Int. Hex)
K	Fixed Locking
L	Long Rotating (Slotted)
M	Med. Rotating (Slotted)
P	Rotating (Hex)
S	Short Rotating (Slotted)
T	Fixed Locking w/ Mtg. Stud
X	Round Guides
Y	"D" Shaped Guides (Polarizing)
0	No Hardware Supplied

Notes:  
 1. For Termination Style E, X, L.  
 2. For Termination Style A, B, D, R, S, V, W

### RECEPTACLE, STACKING STYLE FAE9, FVEA

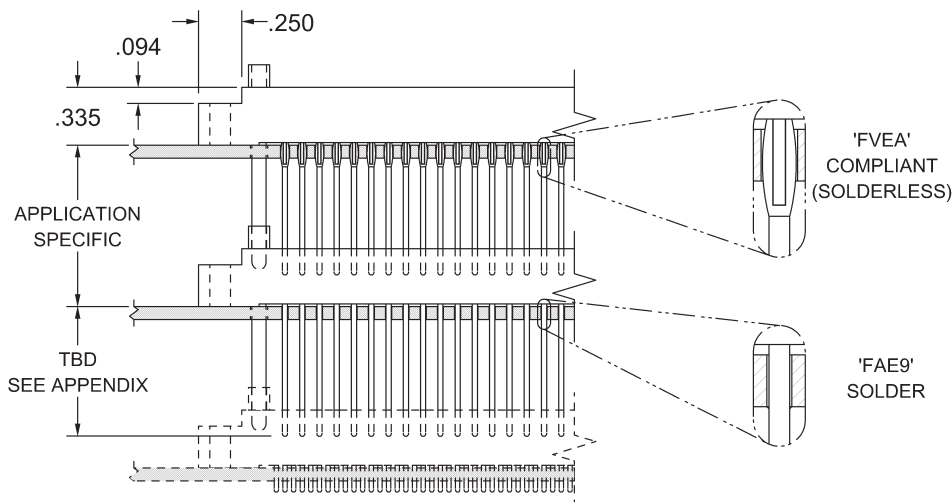
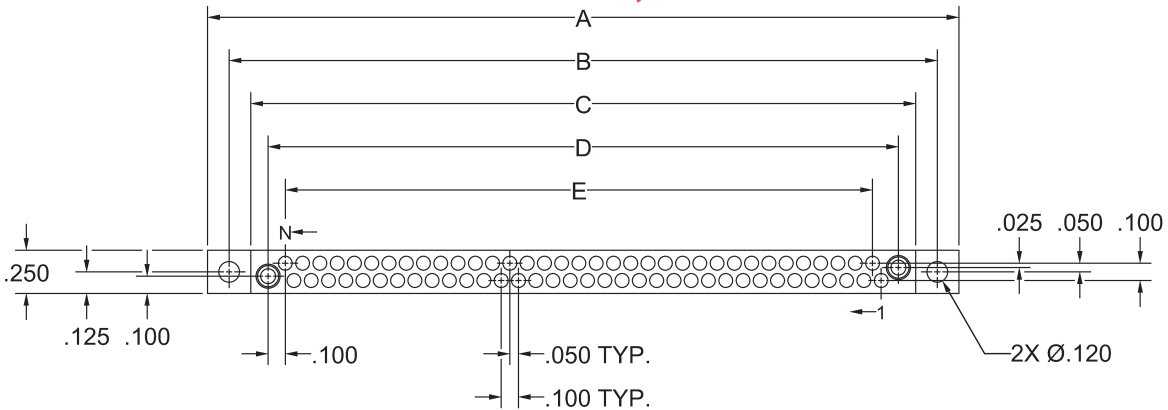

'N' Contacts	A	B	C	D	E
010	1.350	1.100	.850	.650	.400
014	1.550	1.300	1.050	.850	.600
020	1.850	1.600	1.350	1.150	.900
024	2.050	1.800	1.550	1.350	1.100
026	2.150	1.900	1.650	1.450	1.200
030	2.350	2.100	1.850	1.650	1.400
036	2.650	2.400	2.150	1.950	1.700
040	2.850	2.600	2.350	2.150	1.900
044	3.050	2.800	2.550	2.350	2.100
050	3.350	3.100	2.850	2.650	2.400
054	3.550	3.300	3.050	2.850	2.600
056	3.650	3.400	3.150	2.950	2.700
060	3.850	3.600	3.350	3.150	2.900
066	4.150	3.900	3.650	3.450	3.200
070	4.350	4.100	3.850	3.650	3.400

**REFER TO APPENDIX FOR  
TERMINATION DETAILS,  
HARDWARE STYLES,  
POLARIZATION CHART,  
AND PWB PATTERNS**



**RECEPTACLE, STRAIGHT  
STYLE FBE, FDE, FSE, FWE**

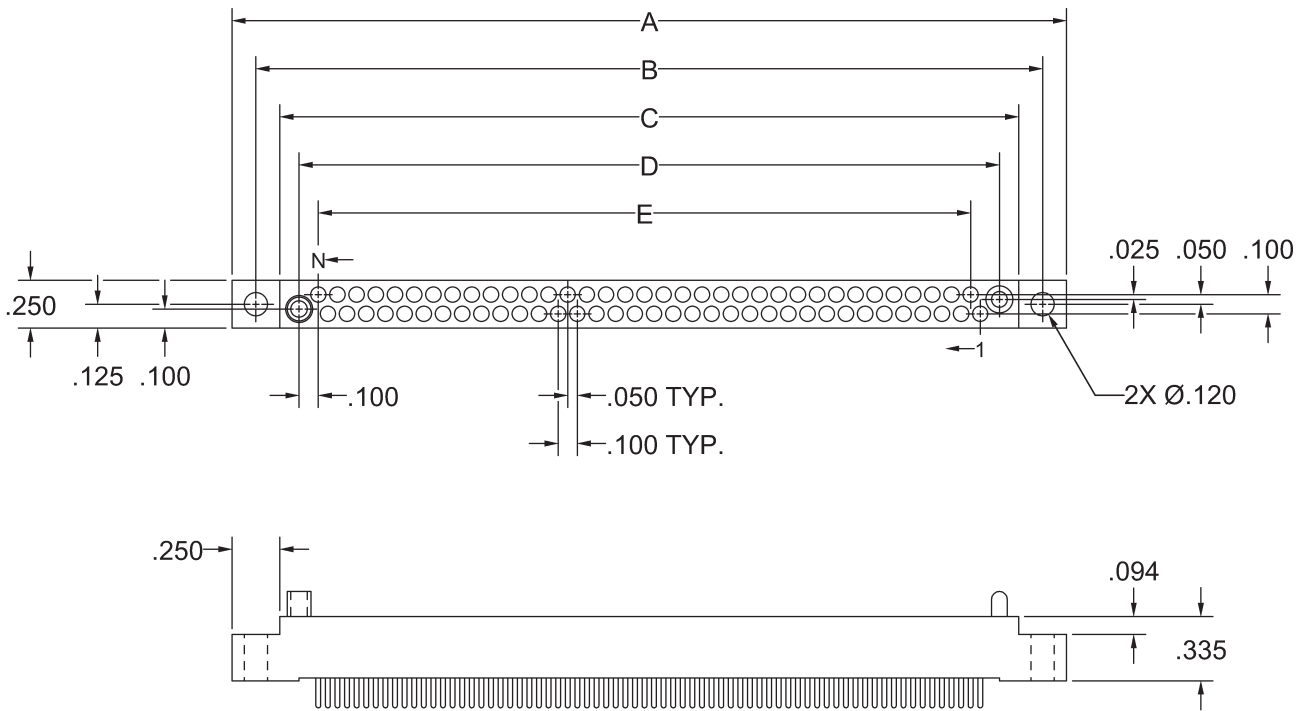

'N' Contacts	A	B	C	D	E
010	1.350	1.100	.850	.650	.400
014	1.550	1.300	1.050	.850	.600
020	1.850	1.600	1.350	1.150	.900
024	2.050	1.800	1.550	1.350	1.100
026	2.150	1.900	1.650	1.450	1.200
030	2.350	2.100	1.850	1.650	1.400
036	2.650	2.400	2.150	1.950	1.700
040	2.850	2.600	2.350	2.150	1.900
044	3.050	2.800	2.550	2.350	2.100
050	3.350	3.100	2.850	2.650	2.400
054	3.550	3.300	3.050	2.850	2.600
056	3.650	3.400	3.150	2.950	2.700
060	3.850	3.600	3.350	3.150	2.900
066	4.150	3.900	3.650	3.450	3.200
070	4.350	4.100	3.850	3.650	3.400

**REFER TO APPENDIX FOR  
TERMINATION DETAILS,  
HARDWARE STYLES,  
POLARIZATION CHART,  
AND PWB PATTERNS**

## RECEPTACLE, RIGHT ANGLE STYLE FEE

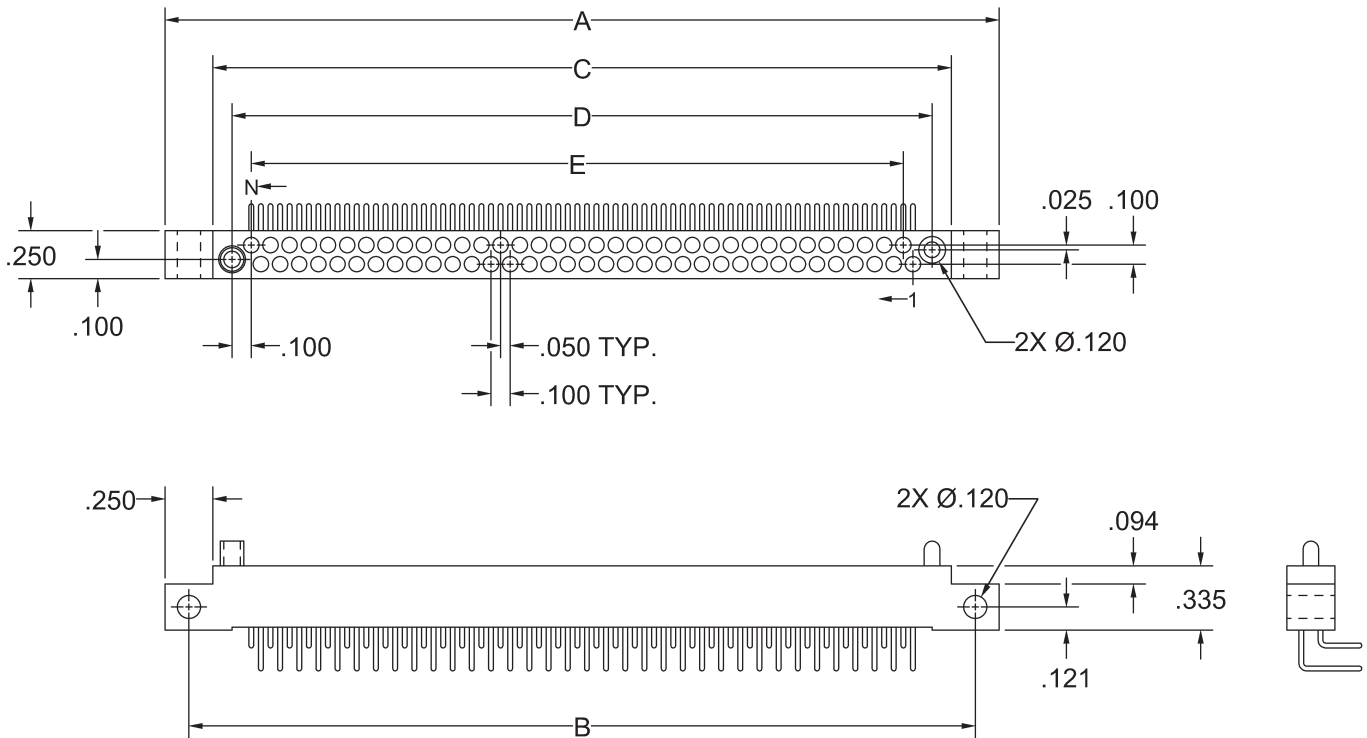

'N' Contacts	A	B	C	D	E
010	1.350	1.100	.850	.650	.400
014	1.550	1.300	1.050	.850	.600
020	1.850	1.600	1.350	1.150	.900
024	2.050	1.800	1.550	1.350	1.100
026	2.150	1.900	1.650	1.450	1.200
030	2.350	2.100	1.850	1.650	1.400
036	2.650	2.400	2.150	1.950	1.700
040	2.850	2.600	2.350	2.150	1.900
044	3.050	2.800	2.550	2.350	2.100
050	3.350	3.100	2.850	2.650	2.400
054	3.550	3.300	3.050	2.850	2.600
056	3.650	3.400	3.150	2.950	2.700
060	3.850	3.600	3.350	3.150	2.900
066	4.150	3.900	3.650	3.450	3.200
070	4.350	4.100	3.850	3.650	3.400

**REFER TO APPENDIX FOR  
 TERMINATION DETAILS,  
 HARDWARE STYLES,  
 POLARIZATION CHART,  
 AND PWB PATTERNS**

## RECEPTACLE, SURFACE MOUNT STYLE FRE

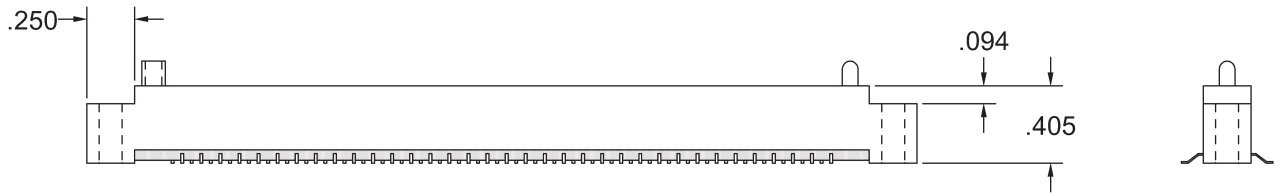
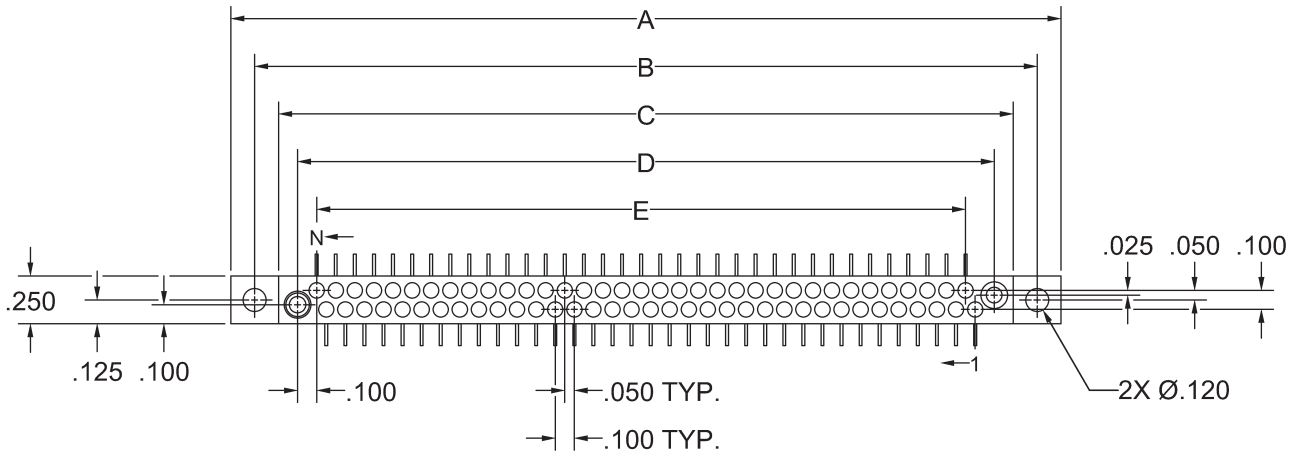

'N' Contacts	A	B	C	D	E
010	1.350	1.100	.850	.650	.400
014	1.550	1.300	1.050	.850	.600
020	1.850	1.600	1.350	1.150	.900
024	2.050	1.800	1.550	1.350	1.100
026	2.150	1.900	1.650	1.450	1.200
030	2.350	2.100	1.850	1.650	1.400
036	2.650	2.400	2.150	1.950	1.700
040	2.850	2.600	2.350	2.150	1.900
044	3.050	2.800	2.550	2.350	2.100
050	3.350	3.100	2.850	2.650	2.400
054	3.550	3.300	3.050	2.850	2.600
056	3.650	3.400	3.150	2.950	2.700
060	3.850	3.600	3.350	3.150	2.900
066	4.150	3.900	3.650	3.450	3.200
070	4.350	4.100	3.850	3.650	3.400

**REFER TO APPENDIX FOR  
TERMINATION DETAILS,  
HARDWARE STYLES,  
POLARIZATION CHART,  
AND PWB PATTERNS**

**RECEPTACLE, COMPLIANT  
STYLE FVE**

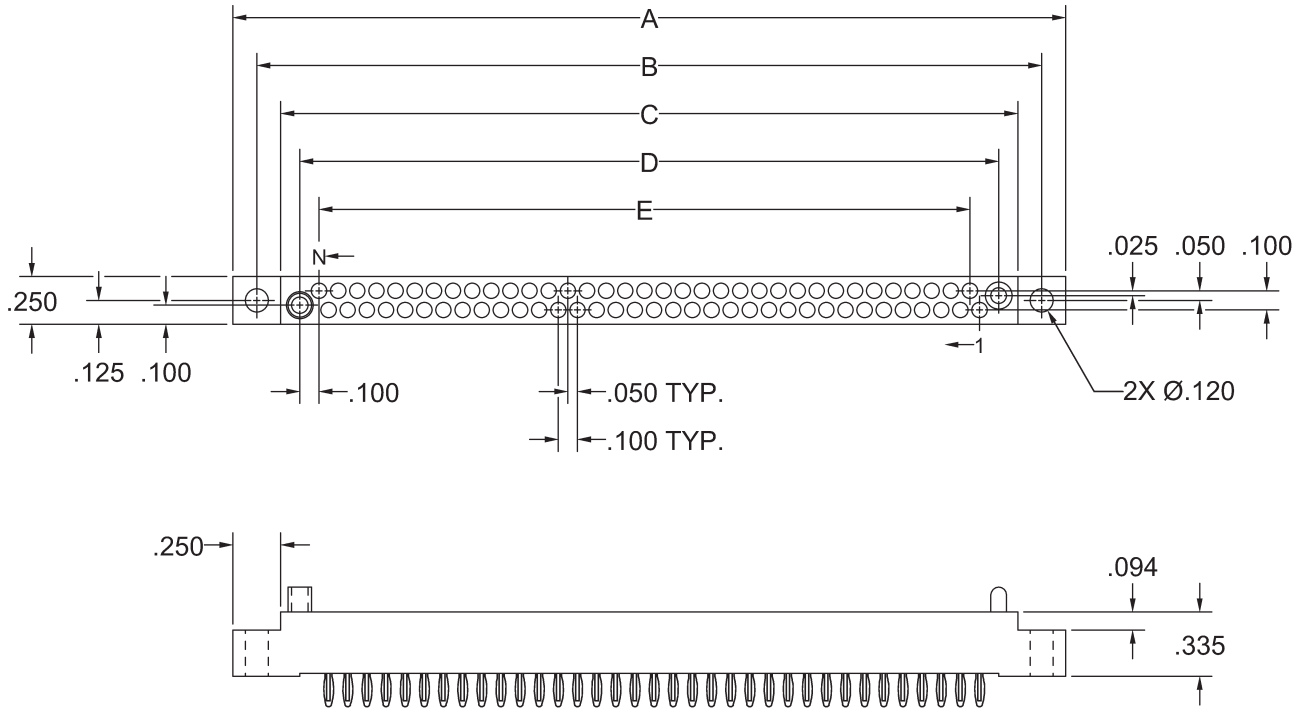

'N' Contacts	A	B	C	D	E
010	1.350	1.100	.850	.650	.400
014	1.550	1.300	1.050	.850	.600
020	1.850	1.600	1.350	1.150	.900
024	2.050	1.800	1.550	1.350	1.100
026	2.150	1.900	1.650	1.450	1.200
030	2.350	2.100	1.850	1.650	1.400
036	2.650	2.400	2.150	1.950	1.700
040	2.850	2.600	2.350	2.150	1.900
044	3.050	2.800	2.550	2.350	2.100
050	3.350	3.100	2.850	2.650	2.400
054	3.550	3.300	3.050	2.850	2.600
056	3.650	3.400	3.150	2.950	2.700
060	3.850	3.600	3.350	3.150	2.900
066	4.150	3.900	3.650	3.450	3.200
070	4.350	4.100	3.850	3.650	3.400

**REFER TO APPENDIX FOR  
TERMINATION DETAILS,  
HARDWARE STYLES,  
POLARIZATION CHART,  
AND PWB PATTERNS**

**RECEPTACLE, PLUG PATTERN, STACKING  
STYLE SAE9, SVEA**

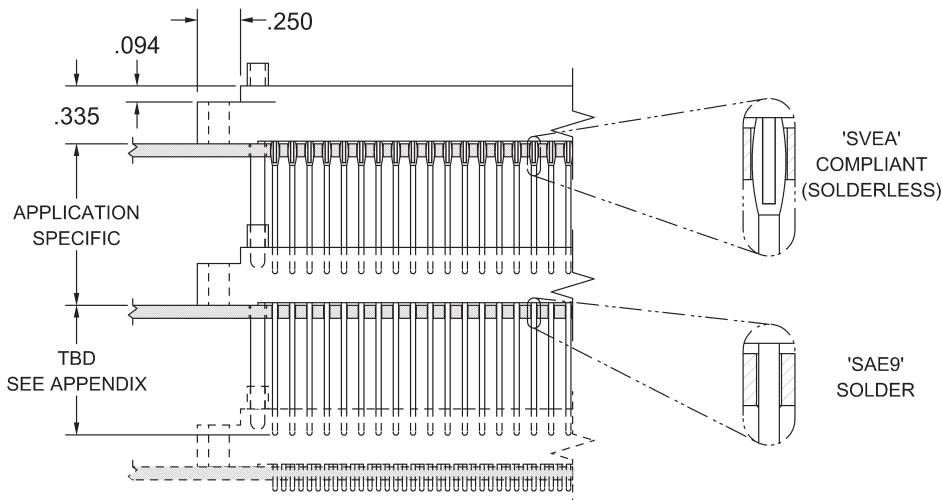
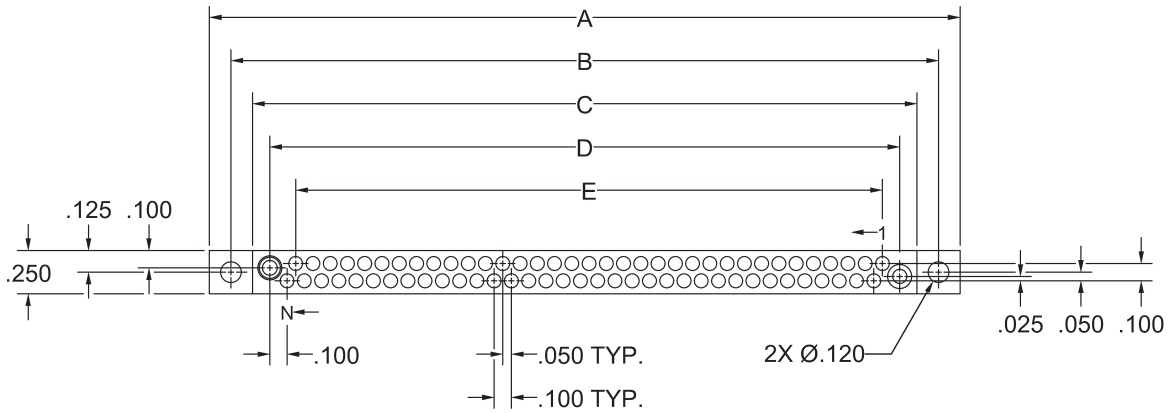

'N' Contacts	A	B	C	D	E
010	1.350	1.100	.850	.650	.400
014	1.550	1.300	1.050	.850	.600
020	1.850	1.600	1.350	1.150	.900
024	2.050	1.800	1.550	1.350	1.100
026	2.150	1.900	1.650	1.450	1.200
030	2.350	2.100	1.850	1.650	1.400
036	2.650	2.400	2.150	1.950	1.700
040	2.850	2.600	2.350	2.150	1.900
044	3.050	2.800	2.550	2.350	2.100
050	3.350	3.100	2.850	2.650	2.400
054	3.550	3.300	3.050	2.850	2.600
056	3.650	3.400	3.150	2.950	2.700
060	3.850	3.600	3.350	3.150	2.900
066	4.150	3.900	3.650	3.450	3.200
070	4.350	4.100	3.850	3.650	3.400

**REFER TO APPENDIX FOR  
TERMINATION DETAILS,  
HARDWARE STYLES,  
POLARIZATION CHART,  
AND PWB PATTERNS**

**RECEPTACLE, PLUG PATTERN, STRAIGHT  
STYLE SBE, SDE, SSE, SWE**

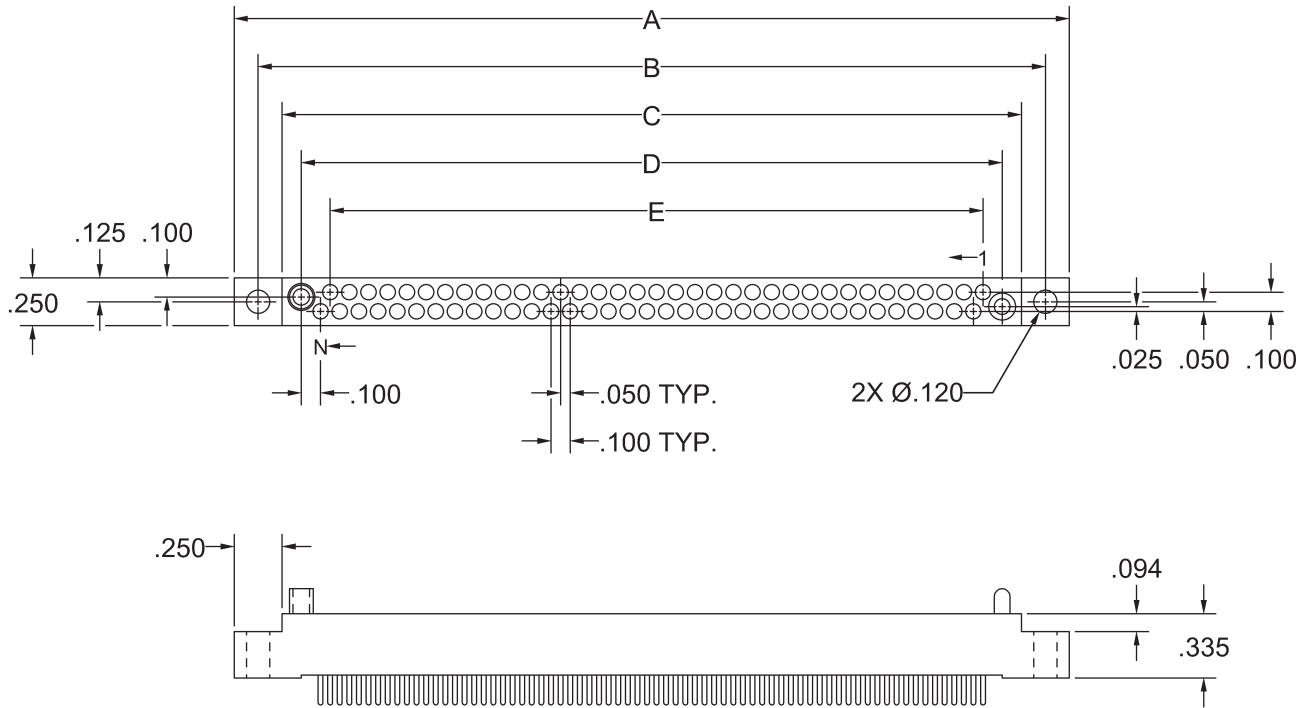

'N' Contacts	A	B	C	D	E
010	1.350	1.100	.850	.650	.400
014	1.550	1.300	1.050	.850	.600
020	1.850	1.600	1.350	1.150	.900
024	2.050	1.800	1.550	1.350	1.100
026	2.150	1.900	1.650	1.450	1.200
030	2.350	2.100	1.850	1.650	1.400
036	2.650	2.400	2.150	1.950	1.700
040	2.850	2.600	2.350	2.150	1.900
044	3.050	2.800	2.550	2.350	2.100
050	3.350	3.100	2.850	2.650	2.400
054	3.550	3.300	3.050	2.850	2.600
056	3.650	3.400	3.150	2.950	2.700
060	3.850	3.600	3.350	3.150	2.900
066	4.150	3.900	3.650	3.450	3.200
070	4.350	4.100	3.850	3.650	3.400

**REFER TO APPENDIX FOR  
TERMINATION DETAILS,  
HARDWARE STYLES,  
POLARIZATION CHART,  
AND PWB PATTERNS**

**RECEPTACLE, PLUG PATTERN, RIGHT ANGLE  
STYLE SEE**

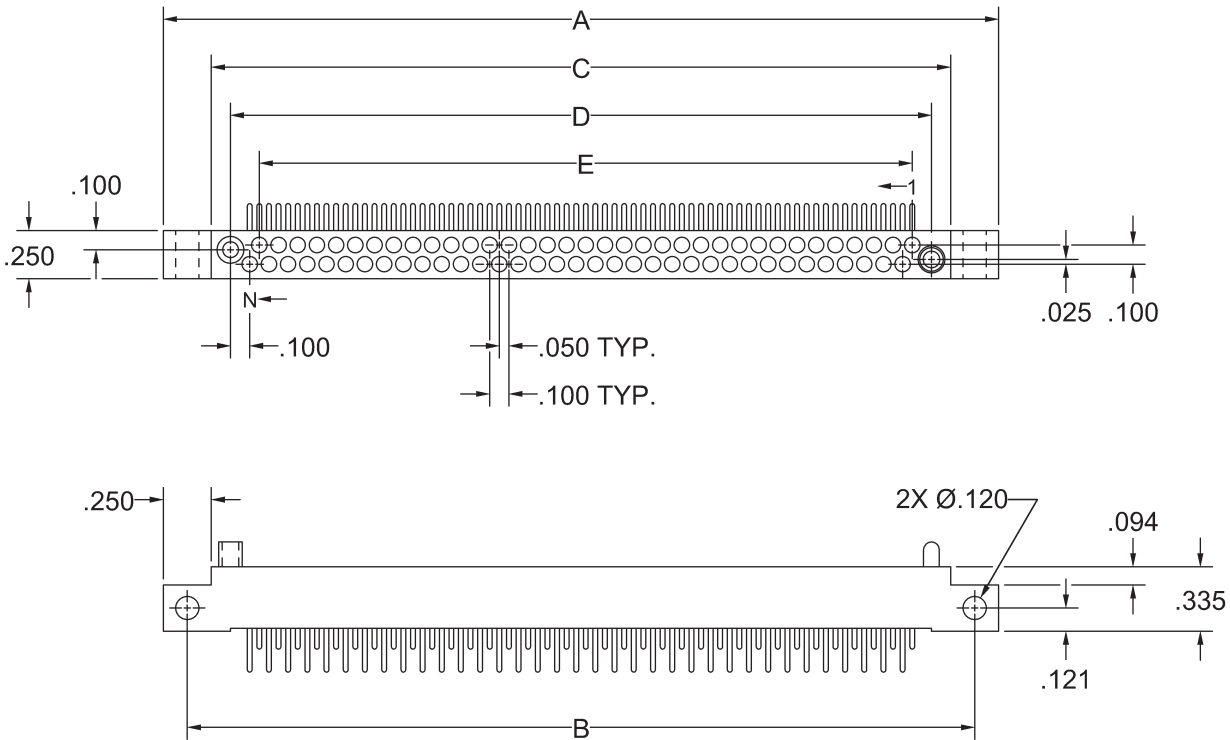

'N' Contacts	A	B	C	D	E
010	1.350	1.100	.850	.650	.400
014	1.550	1.300	1.050	.850	.600
020	1.850	1.600	1.350	1.150	.900
024	2.050	1.800	1.550	1.350	1.100
026	2.150	1.900	1.650	1.450	1.200
030	2.350	2.100	1.850	1.650	1.400
036	2.650	2.400	2.150	1.950	1.700
040	2.850	2.600	2.350	2.150	1.900
044	3.050	2.800	2.550	2.350	2.100
050	3.350	3.100	2.850	2.650	2.400
054	3.550	3.300	3.050	2.850	2.600
056	3.650	3.400	3.150	2.950	2.700
060	3.850	3.600	3.350	3.150	2.900
066	4.150	3.900	3.650	3.450	3.200
070	4.350	4.100	3.850	3.650	3.400

**REFER TO APPENDIX FOR  
TERMINATION DETAILS,  
HARDWARE STYLES,  
POLARIZATION CHART,  
AND PWB PATTERNS**

**RECEPTACLE, PLUG PATTERN, SURFACE MOUNT  
STYLE SRE**

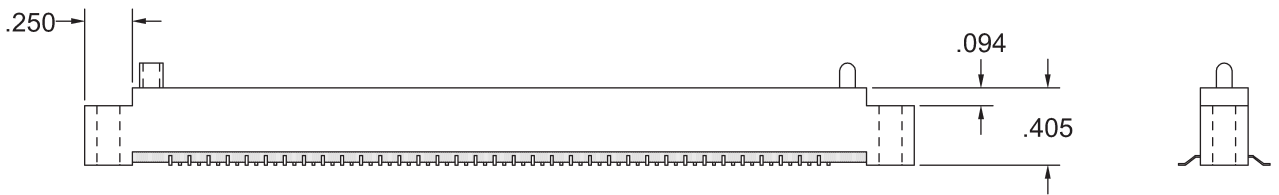
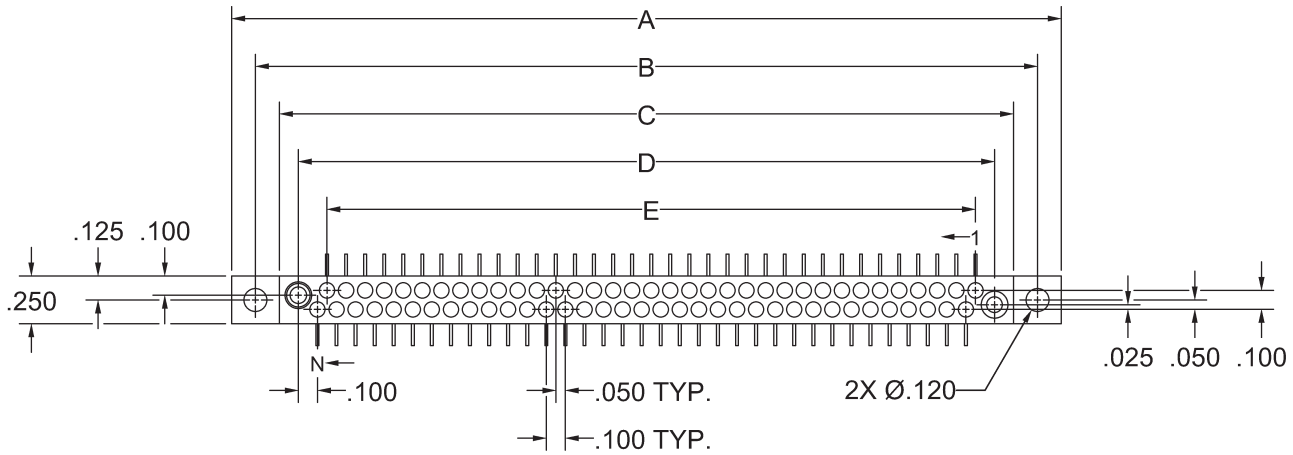

'N' Contacts	A	B	C	D	E
010	1.350	1.100	.850	.650	.400
014	1.550	1.300	1.050	.850	.600
020	1.850	1.600	1.350	1.150	.900
024	2.050	1.800	1.550	1.350	1.100
026	2.150	1.900	1.650	1.450	1.200
030	2.350	2.100	1.850	1.650	1.400
036	2.650	2.400	2.150	1.950	1.700
040	2.850	2.600	2.350	2.150	1.900
044	3.050	2.800	2.550	2.350	2.100
050	3.350	3.100	2.850	2.650	2.400
054	3.550	3.300	3.050	2.850	2.600
056	3.650	3.400	3.150	2.950	2.700
060	3.850	3.600	3.350	3.150	2.900
066	4.150	3.900	3.650	3.450	3.200
070	4.350	4.100	3.850	3.650	3.400

**REFER TO APPENDIX FOR  
TERMINATION DETAILS,  
HARDWARE STYLES,  
POLARIZATION CHART,  
AND PWB PATTERNS**



**RECEPTACLE, PLUG PATTERN, COMPLIANT  
STYLE SVE**

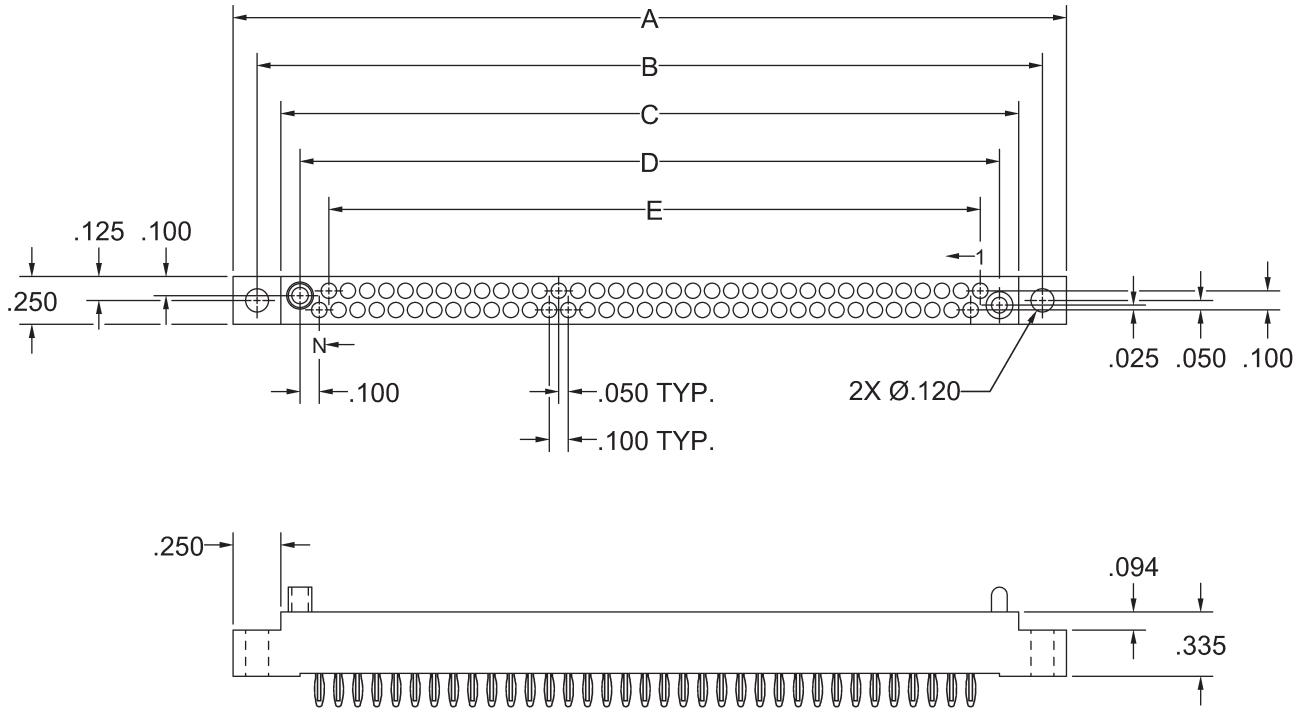

'N' Contacts	A	B	C	D	E
010	1.350	1.100	.850	.650	.400
014	1.550	1.300	1.050	.850	.600
020	1.850	1.600	1.350	1.150	.900
024	2.050	1.800	1.550	1.350	1.100
026	2.150	1.900	1.650	1.450	1.200
030	2.350	2.100	1.850	1.650	1.400
036	2.650	2.400	2.150	1.950	1.700
040	2.850	2.600	2.350	2.150	1.900
044	3.050	2.800	2.550	2.350	2.100
050	3.350	3.100	2.850	2.650	2.400
054	3.550	3.300	3.050	2.850	2.600
056	3.650	3.400	3.150	2.950	2.700
060	3.850	3.600	3.350	3.150	2.900
066	4.150	3.900	3.650	3.450	3.200
070	4.350	4.100	3.850	3.650	3.400

**REFER TO APPENDIX FOR  
TERMINATION DETAILS,  
HARDWARE STYLES,  
POLARIZATION CHART,  
AND PWB PATTERNS**

## PLUG, RECEPTACLE PATTERN, STACKING STYLE MAE9, MVEA

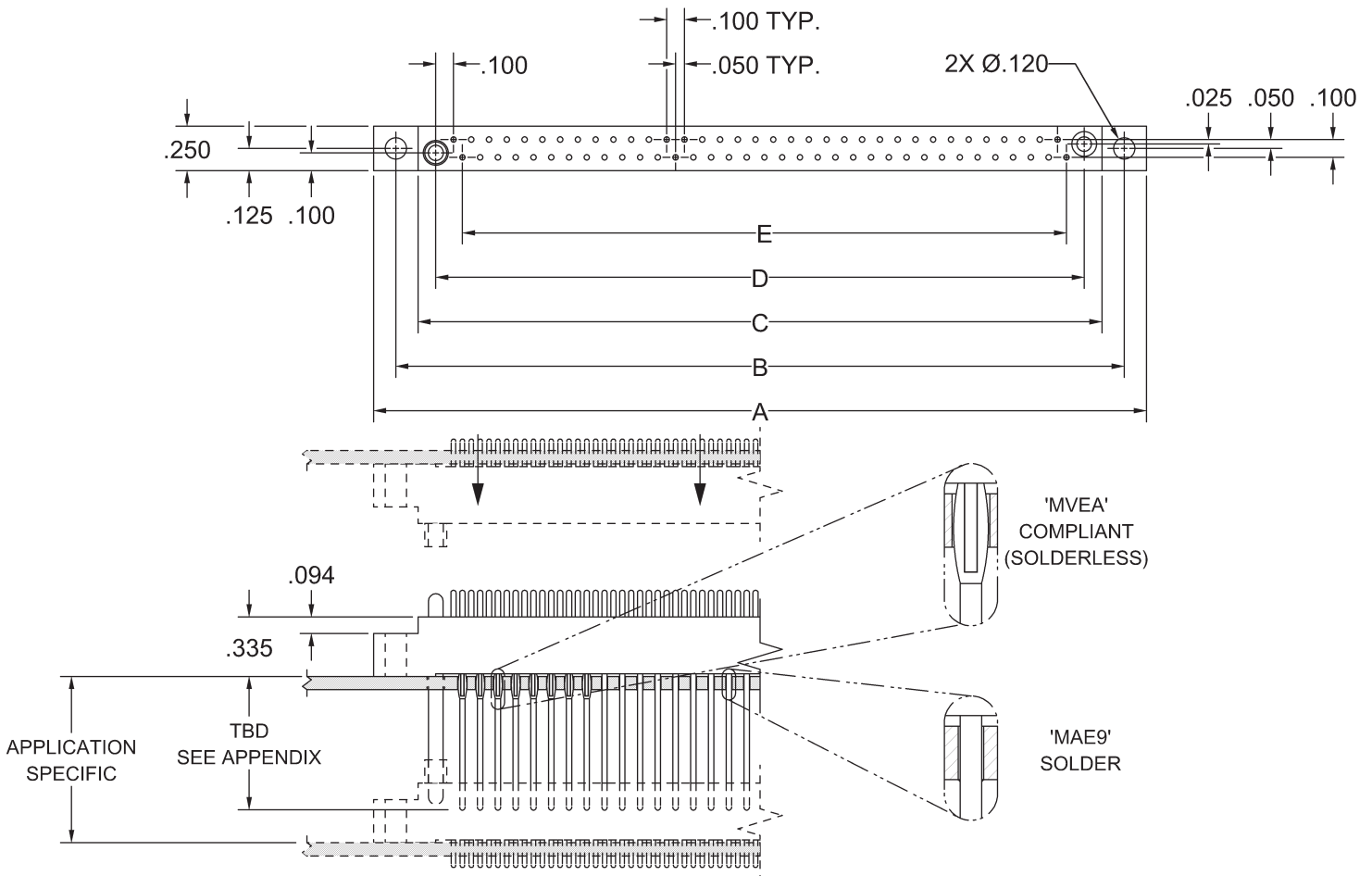

'N' Contacts	A	B	C	D	E
010	1.350	1.100	.850	.650	.400
014	1.550	1.300	1.050	.850	.600
020	1.850	1.600	1.350	1.150	.900
024	2.050	1.800	1.550	1.350	1.100
026	2.150	1.900	1.650	1.450	1.200
030	2.350	2.100	1.850	1.650	1.400
036	2.650	2.400	2.150	1.950	1.700
040	2.850	2.600	2.350	2.150	1.900
044	3.050	2.800	2.550	2.350	2.100
050	3.350	3.100	2.850	2.650	2.400
054	3.550	3.300	3.050	2.850	2.600
056	3.650	3.400	3.150	2.950	2.700
060	3.850	3.600	3.350	3.150	2.900
066	4.150	3.900	3.650	3.450	3.200
070	4.350	4.100	3.850	3.650	3.400

REFER TO APPENDIX FOR  
TERMINATION DETAILS,  
HARDWARE STYLES,  
POLARIZATION CHART,  
AND PWB PATTERNS

**PLUG, RECEPTACLE PATTERN, STRAIGHT  
STYLE MBE, MDE, MSE, MWE**

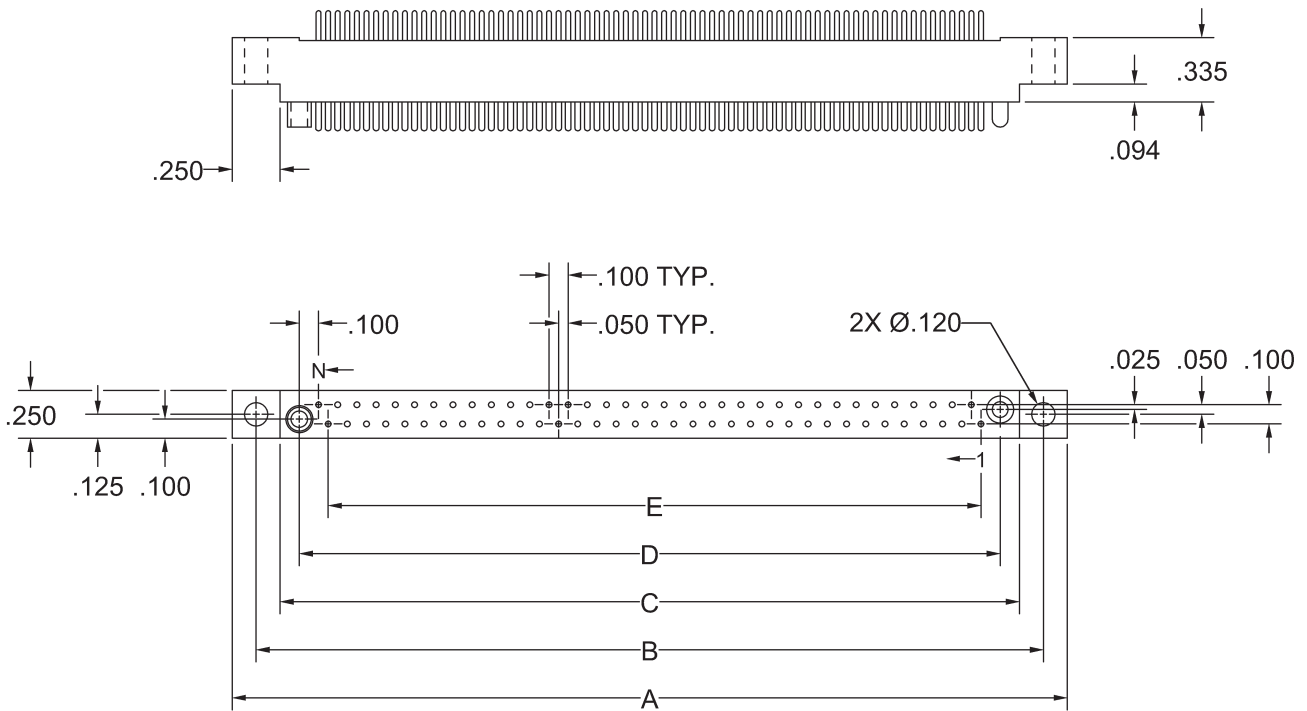

'N' Contacts	A	B	C	D	E
010	1.350	1.100	.850	.650	.400
014	1.550	1.300	1.050	.850	.600
020	1.850	1.600	1.350	1.150	.900
024	2.050	1.800	1.550	1.350	1.100
026	2.150	1.900	1.650	1.450	1.200
030	2.350	2.100	1.850	1.650	1.400
036	2.650	2.400	2.150	1.950	1.700
040	2.850	2.600	2.350	2.150	1.900
044	3.050	2.800	2.550	2.350	2.100
050	3.350	3.100	2.850	2.650	2.400
054	3.550	3.300	3.050	2.850	2.600
056	3.650	3.400	3.150	2.950	2.700
060	3.850	3.600	3.350	3.150	2.900
066	4.150	3.900	3.650	3.450	3.200
070	4.350	4.100	3.850	3.650	3.400

**REFER TO APPENDIX FOR  
TERMINATION DETAILS,  
HARDWARE STYLES,  
POLARIZATION CHART,  
AND PWB PATTERNS**

**PLUG, RIGHT ANGLE  
STYLE MEE, MXE**

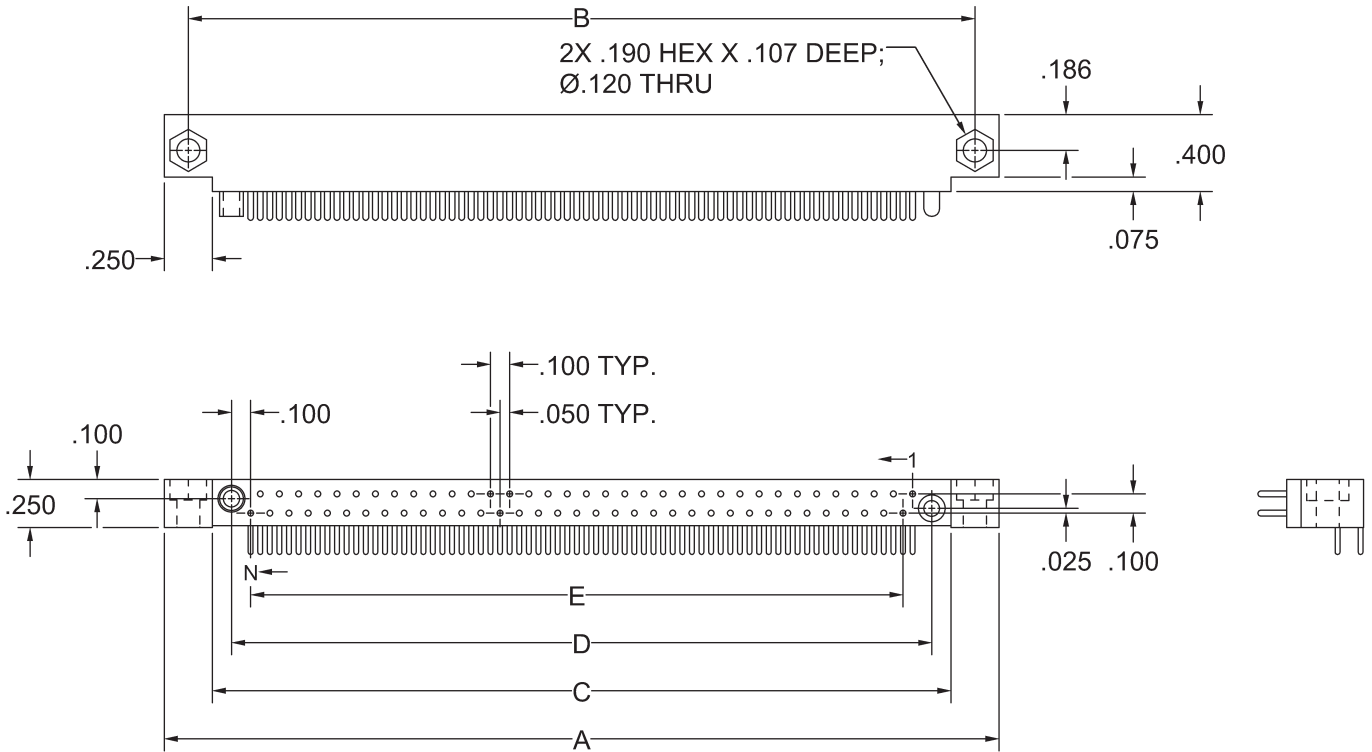

'N' Contacts	A	B	C	D	E
010	1.350	1.100	.850	.650	.400
014	1.550	1.300	1.050	.850	.600
020	1.850	1.600	1.350	1.150	.900
024	2.050	1.800	1.550	1.350	1.100
026	2.150	1.900	1.650	1.450	1.200
030	2.350	2.100	1.850	1.650	1.400
036	2.650	2.400	2.150	1.950	1.700
040	2.850	2.600	2.350	2.150	1.900
044	3.050	2.800	2.550	2.350	2.100
050	3.350	3.100	2.850	2.650	2.400
054	3.550	3.300	3.050	2.850	2.600
056	3.650	3.400	3.150	2.950	2.700
060	3.850	3.600	3.350	3.150	2.900
066	4.150	3.900	3.650	3.450	3.200
070	4.350	4.100	3.850	3.650	3.400

**REFER TO APPENDIX FOR  
TERMINATION DETAILS,  
HARDWARE STYLES,  
POLARIZATION CHART,  
AND PWB PATTERNS**

**PLUG, RIGHT ANGLE, COMPLIANT  
STYLE MLE**

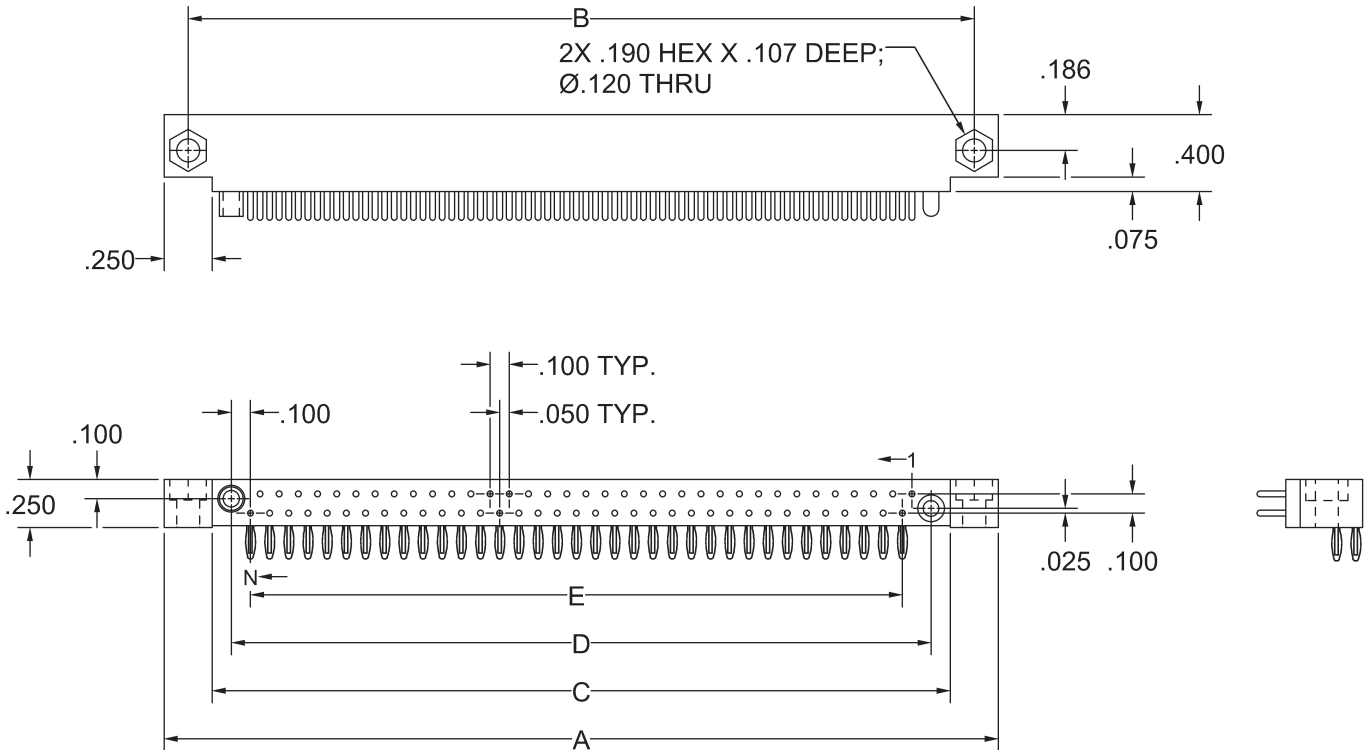

'N' Contacts	A	B	C	D	E
010	1.350	1.100	.850	.650	.400
014	1.550	1.300	1.050	.850	.600
020	1.850	1.600	1.350	1.150	.900
024	2.050	1.800	1.550	1.350	1.100
026	2.150	1.900	1.650	1.450	1.200
030	2.350	2.100	1.850	1.650	1.400
036	2.650	2.400	2.150	1.950	1.700
040	2.850	2.600	2.350	2.150	1.900
044	3.050	2.800	2.550	2.350	2.100
050	3.350	3.100	2.850	2.650	2.400
054	3.550	3.300	3.050	2.850	2.600
056	3.650	3.400	3.150	2.950	2.700
060	3.850	3.600	3.350	3.150	2.900
066	4.150	3.900	3.650	3.450	3.200
070	4.350	4.100	3.850	3.650	3.400

**REFER TO APPENDIX FOR  
TERMINATION DETAILS,  
HARDWARE STYLES,  
POLARIZATION CHART,  
AND PWB PATTERNS**

**PLUG, RECEPTACLE PATTERN, SURFACE MOUNT  
STYLE MRE**

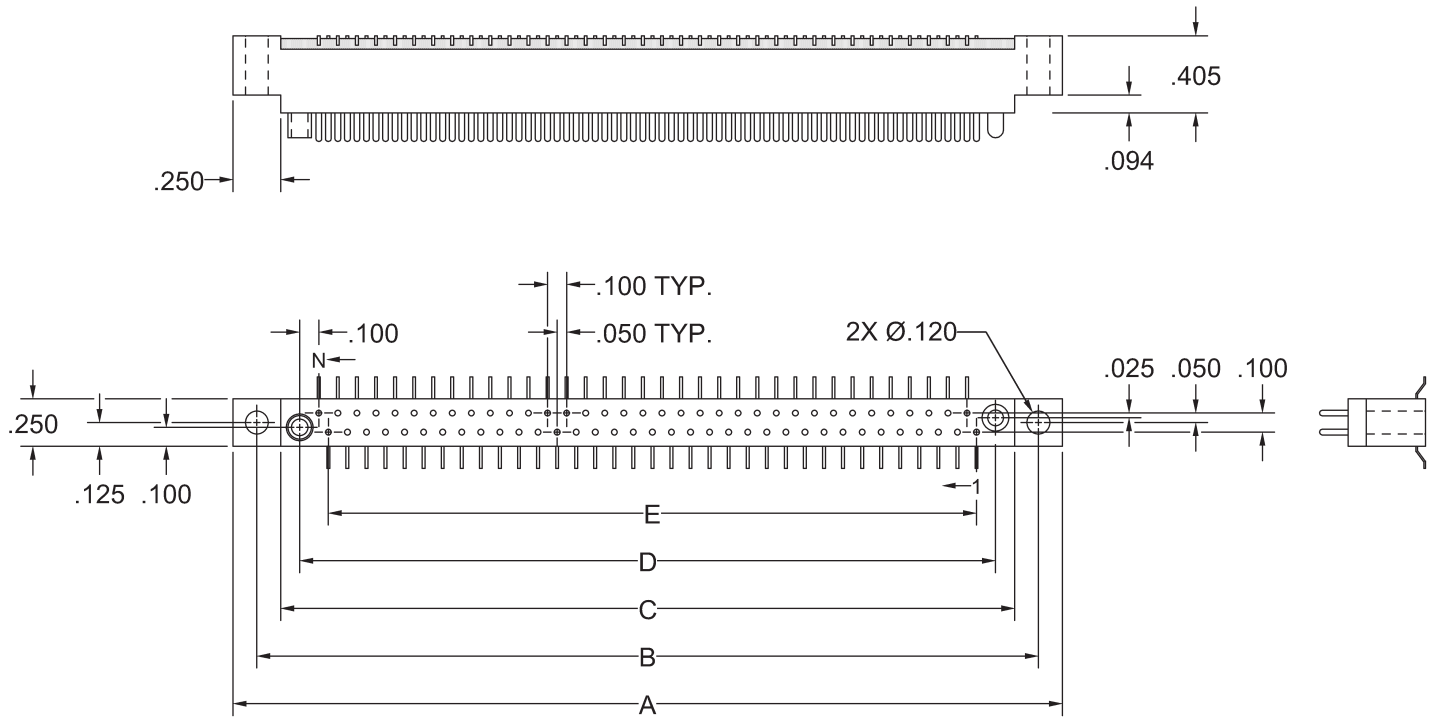

'N' Contacts	A	B	C	D	E
010	1.350	1.100	.850	.650	.400
014	1.550	1.300	1.050	.850	.600
020	1.850	1.600	1.350	1.150	.900
024	2.050	1.800	1.550	1.350	1.100
026	2.150	1.900	1.650	1.450	1.200
030	2.350	2.100	1.850	1.650	1.400
036	2.650	2.400	2.150	1.950	1.700
040	2.850	2.600	2.350	2.150	1.900
044	3.050	2.800	2.550	2.350	2.100
050	3.350	3.100	2.850	2.650	2.400
054	3.550	3.300	3.050	2.850	2.600
056	3.650	3.400	3.150	2.950	2.700
060	3.850	3.600	3.350	3.150	2.900
066	4.150	3.900	3.650	3.450	3.200
070	4.350	4.100	3.850	3.650	3.400

**REFER TO APPENDIX FOR  
TERMINATION DETAILS,  
HARDWARE STYLES,  
POLARIZATION CHART,  
AND PWB PATTERNS**

**PLUG, RECEPTACLE PATTERN, COMPLIANT  
STYLE MVE**

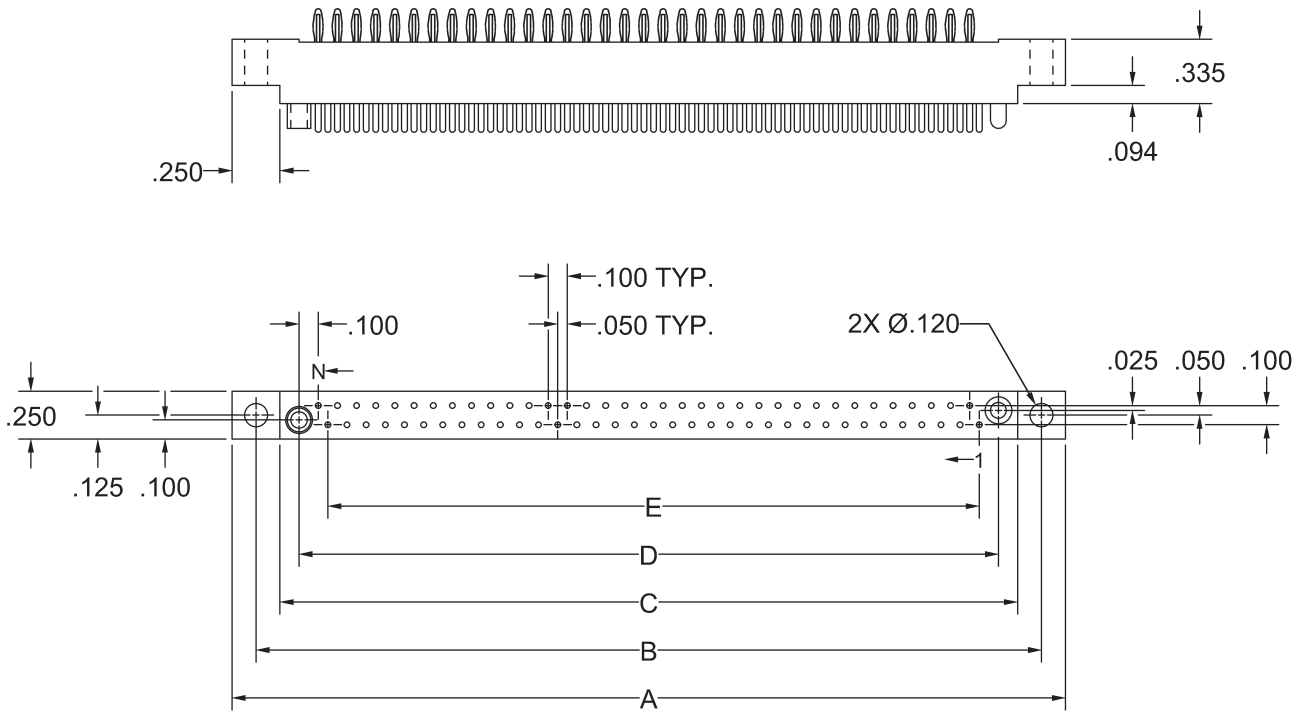

'N' Contacts	A	B	C	D	E
010	1.350	1.100	.850	.650	.400
014	1.550	1.300	1.050	.850	.600
020	1.850	1.600	1.350	1.150	.900
024	2.050	1.800	1.550	1.350	1.100
026	2.150	1.900	1.650	1.450	1.200
030	2.350	2.100	1.850	1.650	1.400
036	2.650	2.400	2.150	1.950	1.700
040	2.850	2.600	2.350	2.150	1.900
044	3.050	2.800	2.550	2.350	2.100
050	3.350	3.100	2.850	2.650	2.400
054	3.550	3.300	3.050	2.850	2.600
056	3.650	3.400	3.150	2.950	2.700
060	3.850	3.600	3.350	3.150	2.900
066	4.150	3.900	3.650	3.450	3.200
070	4.350	4.100	3.850	3.650	3.400

**REFER TO APPENDIX FOR  
TERMINATION DETAILS,  
HARDWARE STYLES,  
POLARIZATION CHART,  
AND PWB PATTERNS**

**PLUG, STACKING  
STYLE PAE9, PVEA**

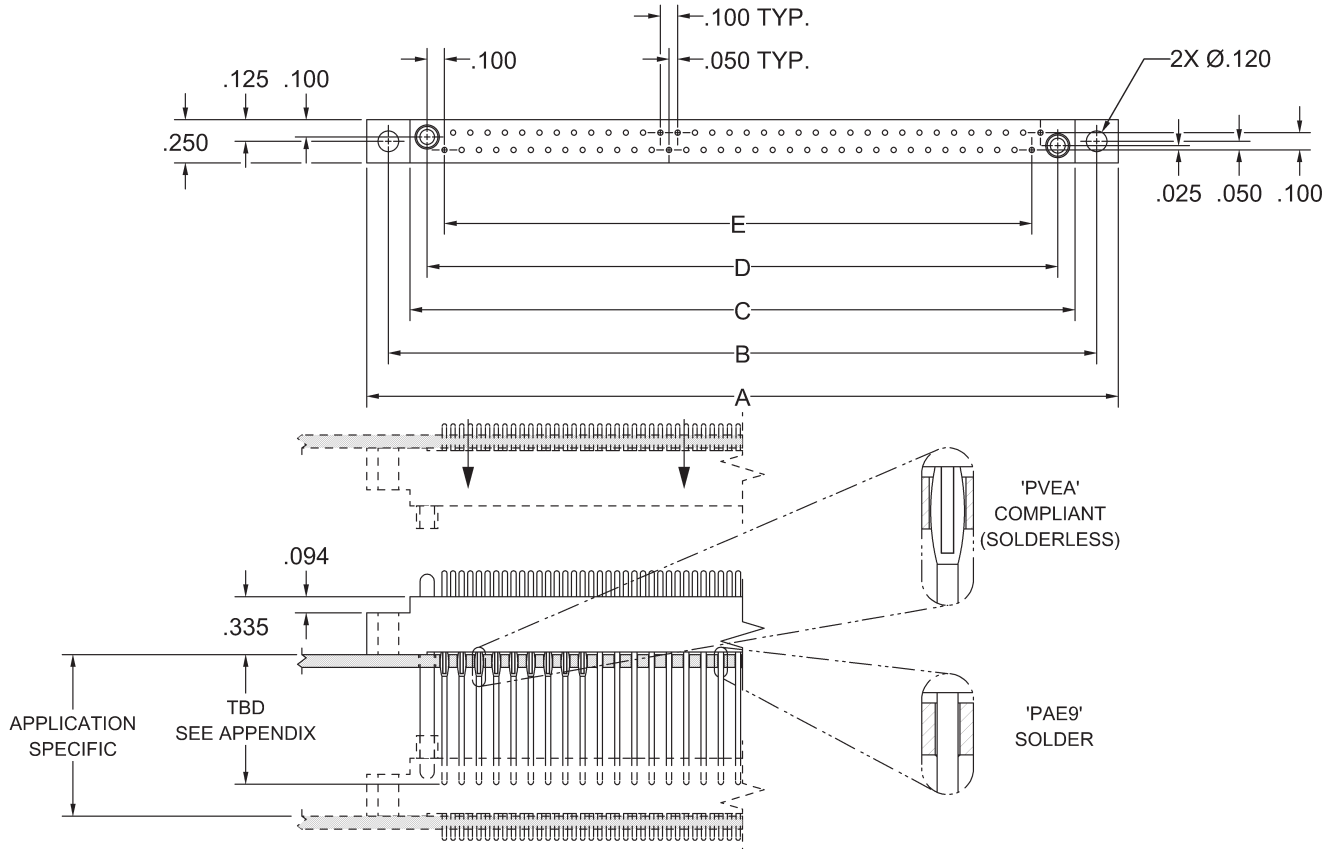

'N' Contacts	A	B	C	D	E
010	1.350	1.100	.850	.650	.400
014	1.550	1.300	1.050	.850	.600
020	1.850	1.600	1.350	1.150	.900
024	2.050	1.800	1.550	1.350	1.100
026	2.150	1.900	1.650	1.450	1.200
030	2.350	2.100	1.850	1.650	1.400
036	2.650	2.400	2.150	1.950	1.700
040	2.850	2.600	2.350	2.150	1.900
044	3.050	2.800	2.550	2.350	2.100
050	3.350	3.100	2.850	2.650	2.400
054	3.550	3.300	3.050	2.850	2.600
056	3.650	3.400	3.150	2.950	2.700
060	3.850	3.600	3.350	3.150	2.900
066	4.150	3.900	3.650	3.450	3.200
070	4.350	4.100	3.850	3.650	3.400

**REFER TO APPENDIX FOR  
TERMINATION DETAILS,  
HARDWARE STYLES,  
POLARIZATION CHART,  
AND PWB PATTERNS**





## PLUG, SURFACE MOUNT STYLE PRE

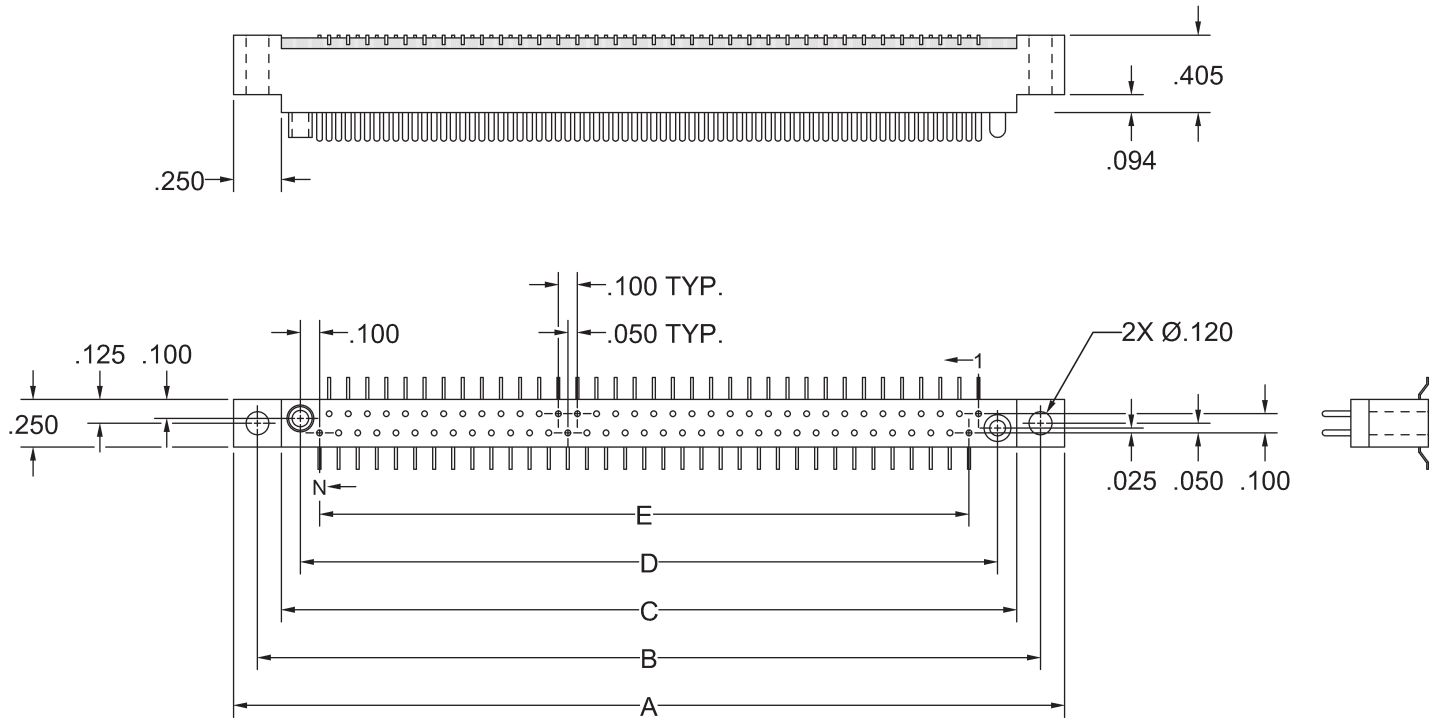

'N' Contacts	A	B	C	D	E
010	1.350	1.100	.850	.650	.400
014	1.550	1.300	1.050	.850	.600
020	1.850	1.600	1.350	1.150	.900
024	2.050	1.800	1.550	1.350	1.100
026	2.150	1.900	1.650	1.450	1.200
030	2.350	2.100	1.850	1.650	1.400
036	2.650	2.400	2.150	1.950	1.700
040	2.850	2.600	2.350	2.150	1.900
044	3.050	2.800	2.550	2.350	2.100
050	3.350	3.100	2.850	2.650	2.400
054	3.550	3.300	3.050	2.850	2.600
056	3.650	3.400	3.150	2.950	2.700
060	3.850	3.600	3.350	3.150	2.900
066	4.150	3.900	3.650	3.450	3.200
070	4.350	4.100	3.850	3.650	3.400

**REFER TO APPENDIX FOR  
TERMINATION DETAILS,  
HARDWARE STYLES,  
POLARIZATION CHART,  
AND PWB PATTERNS**

**PLUG, COMPLIANT  
STYLE PVE**

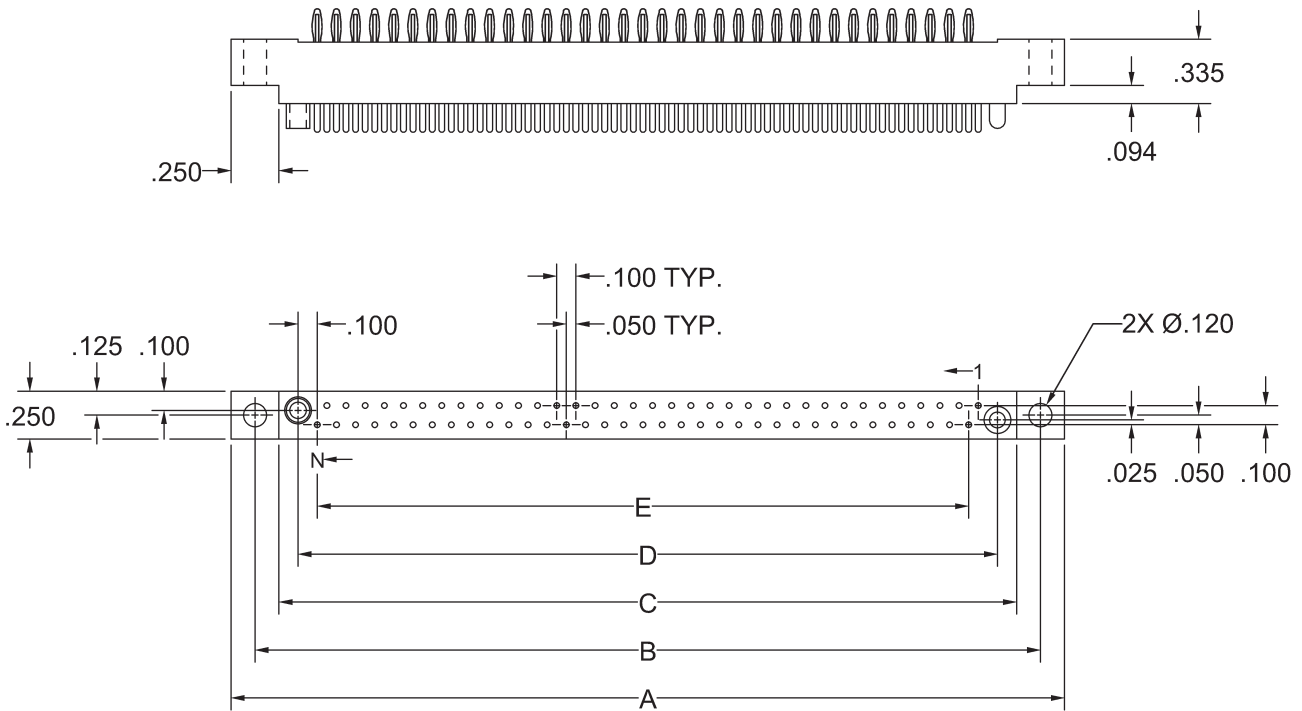

'N' Contacts	A	B	C	D	E
010	1.350	1.100	.850	.650	.400
014	1.550	1.300	1.050	.850	.600
020	1.850	1.600	1.350	1.150	.900
024	2.050	1.800	1.550	1.350	1.100
026	2.150	1.900	1.650	1.450	1.200
030	2.350	2.100	1.850	1.650	1.400
036	2.650	2.400	2.150	1.950	1.700
040	2.850	2.600	2.350	2.150	1.900
044	3.050	2.800	2.550	2.350	2.100
050	3.350	3.100	2.850	2.650	2.400
054	3.550	3.300	3.050	2.850	2.600
056	3.650	3.400	3.150	2.950	2.700
060	3.850	3.600	3.350	3.150	2.900
066	4.150	3.900	3.650	3.450	3.200
070	4.350	4.100	3.850	3.650	3.400

**REFER TO APPENDIX FOR  
TERMINATION DETAILS,  
HARDWARE STYLES,  
POLARIZATION CHART,  
AND PWB PATTERNS**

**RECEPTACLE, STRAIGHT  
STYLE HGM090 FBE, FDE, FSE, FWE**

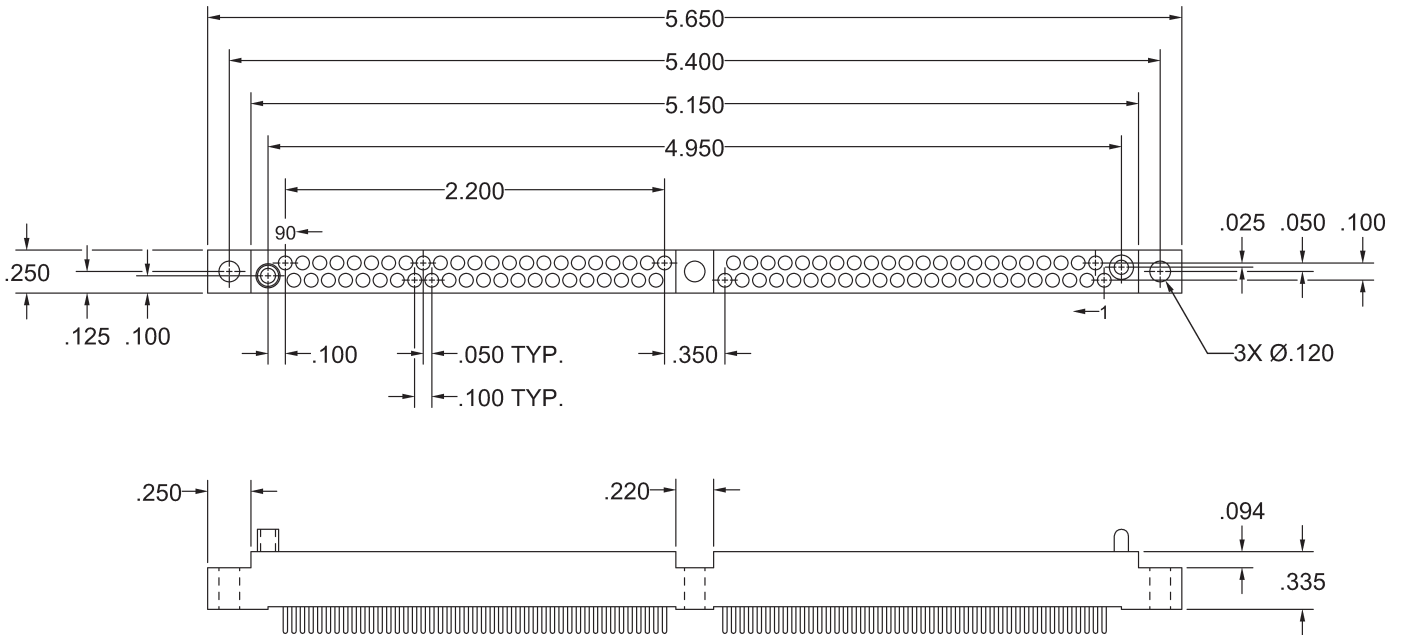

**REFER TO APPENDIX FOR  
TERMINATION DETAILS,  
HARDWARE STYLES,  
POLARIZATION CHART,  
AND PWB PATTERNS**

**RECEPTACLE, RIGHT ANGLE  
STYLE HGM090 FEE**

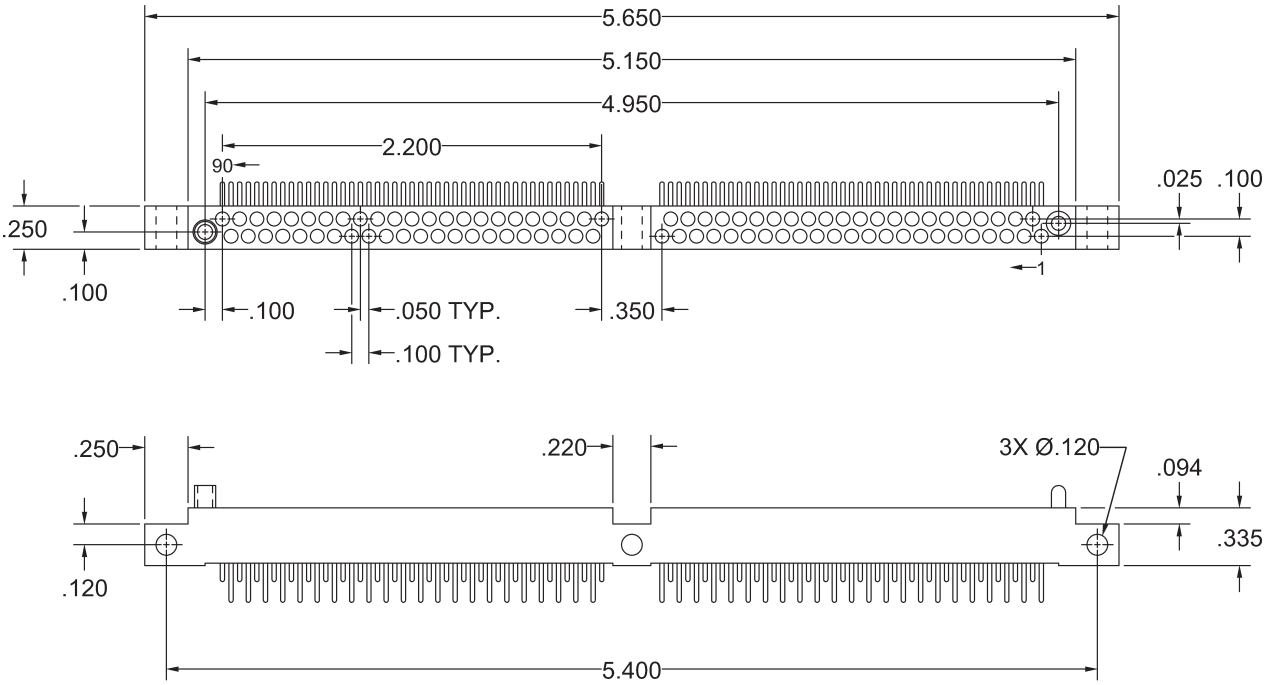

**REFER TO APPENDIX FOR  
TERMINATION DETAILS,  
HARDWARE STYLES,  
POLARIZATION CHART,  
AND PWB PATTERNS**





**PLUG, RIGHT ANGLE  
STYLE HGM090 MEE**

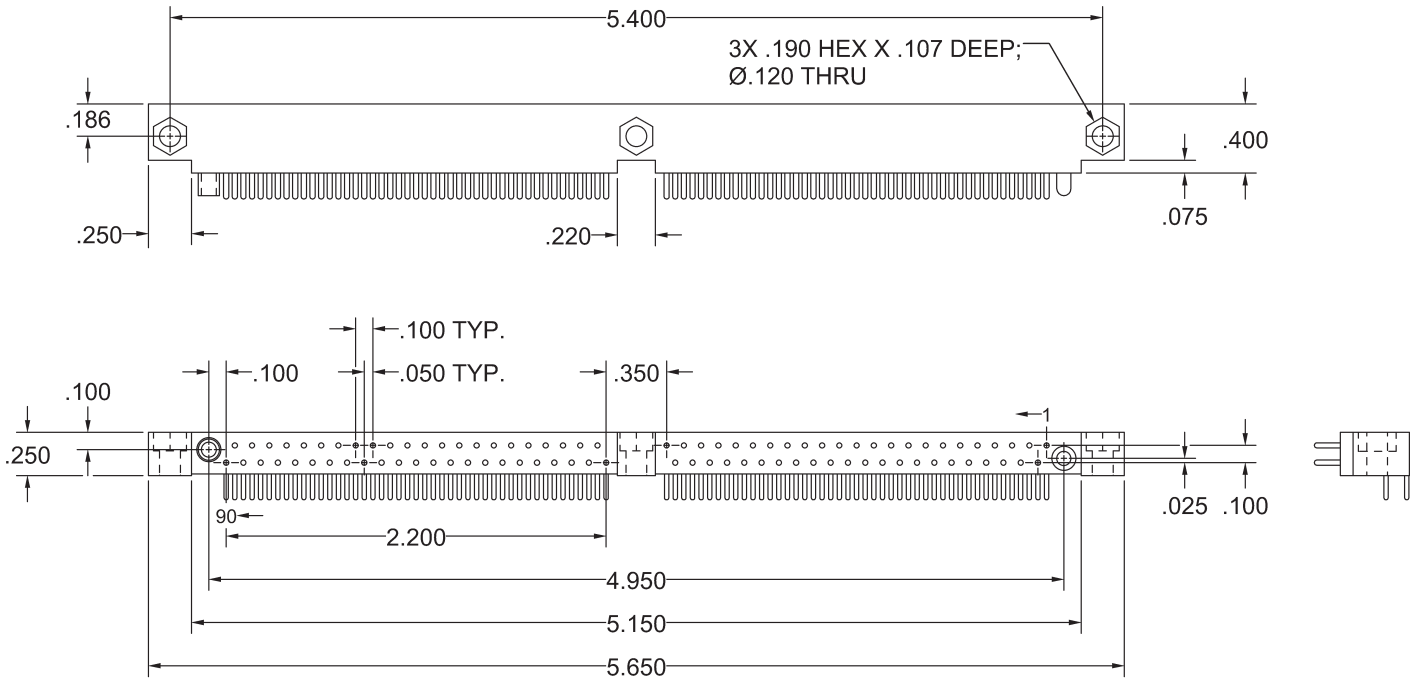

**REFER TO APPENDIX FOR  
TERMINATION DETAILS,  
HARDWARE STYLES,  
POLARIZATION CHART,  
AND PWB PATTERNS**



**PLUG, STRAIGHT  
STYLE HGM090 RBE, RDE, RSE, RWE**

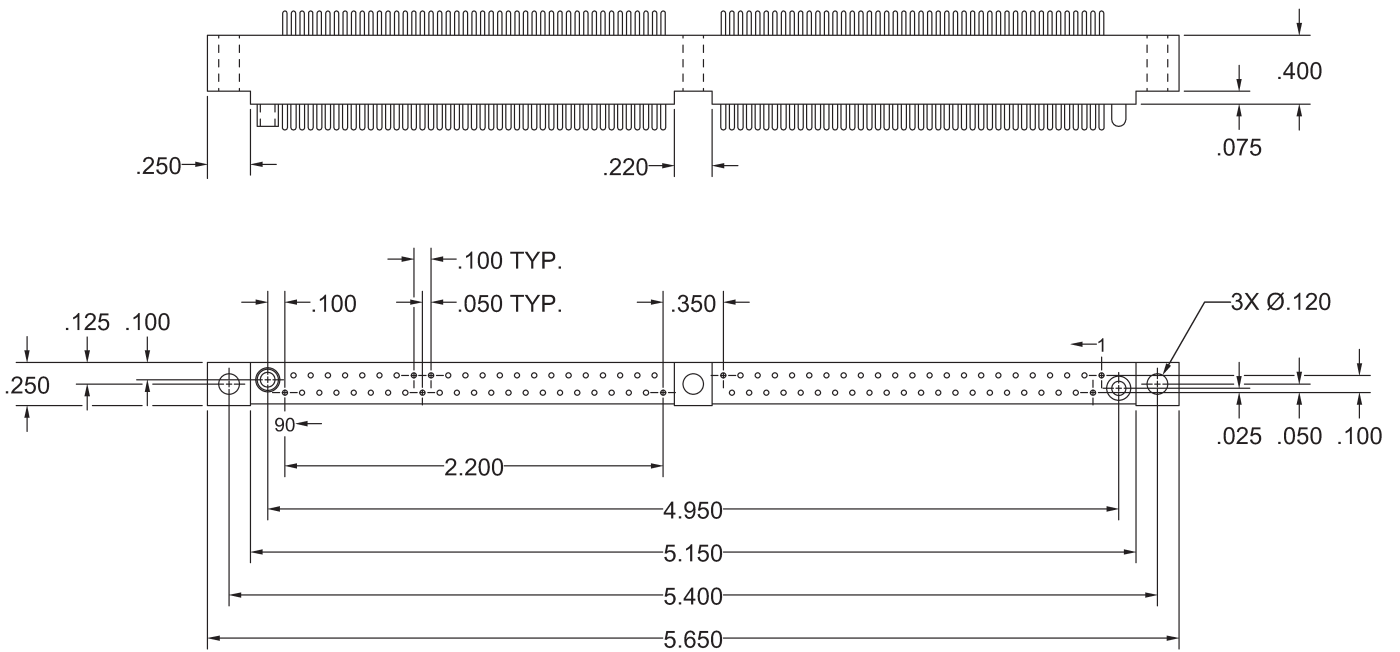

**REFER TO APPENDIX FOR  
TERMINATION DETAILS,  
HARDWARE STYLES,  
POLARIZATION CHART,  
AND PWB PATTERNS**



### RECEPTACLE, RIGHT ANGLE STYLE HGM100 FEE

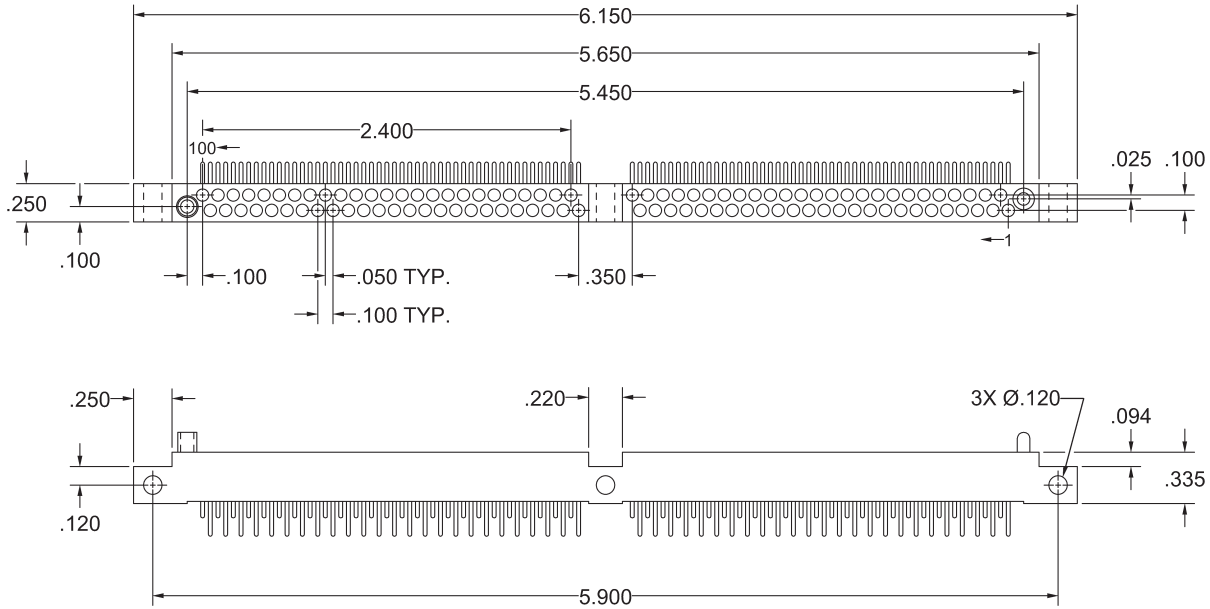

**REFER TO APPENDIX FOR  
TERMINATION DETAILS,  
HARDWARE STYLES,  
POLARIZATION CHART,  
AND PWB PATTERNS**

### RECEPTACLE, SURFACE MOUNT STYLE HGM100 FRE

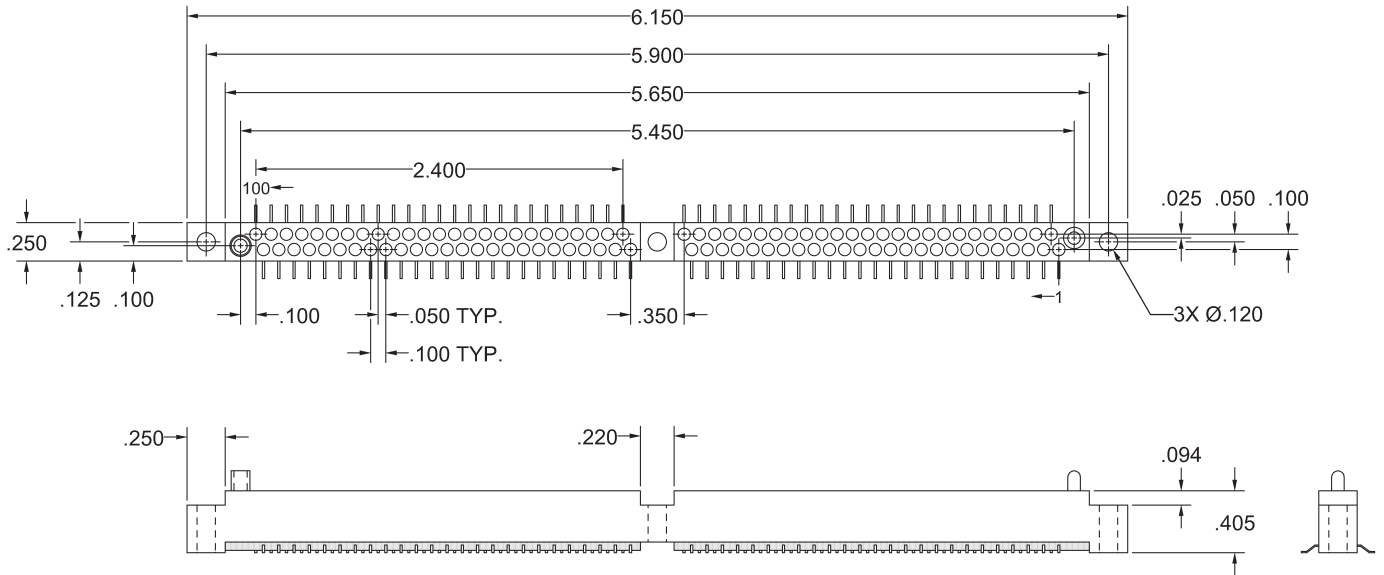

**REFER TO APPENDIX FOR  
TERMINATION DETAILS,  
HARDWARE STYLES,  
POLARIZATION CHART,  
AND PWB PATTERNS**

### RECEPTACLE, COMPLIANT STYLE HGM100 FVE

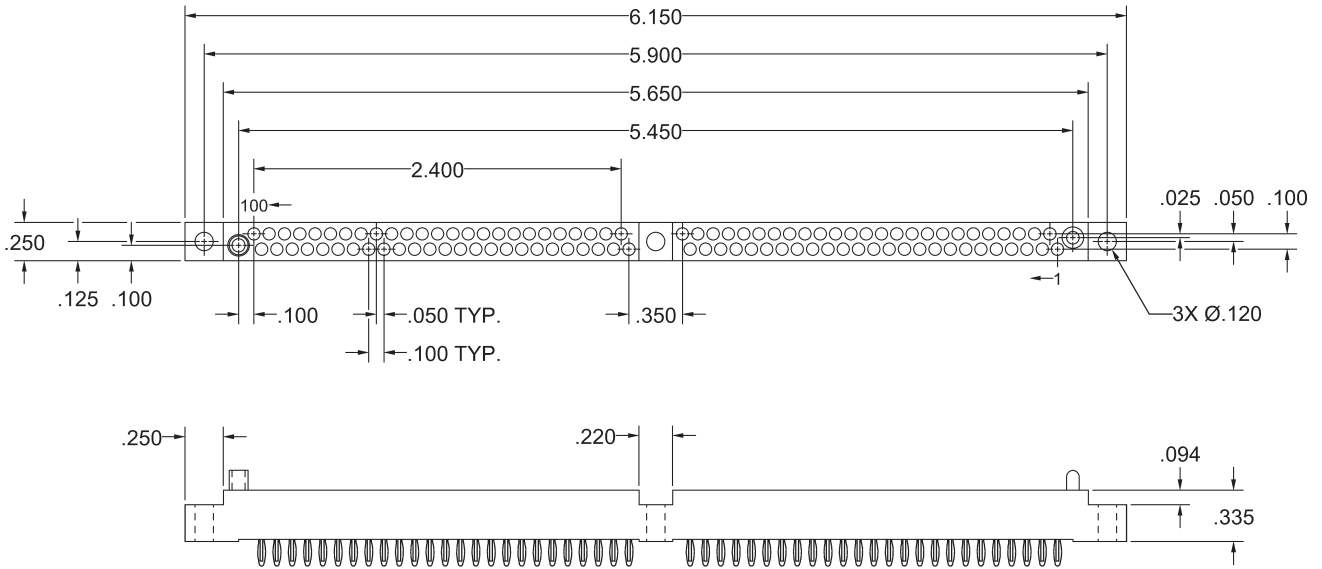

**REFER TO APPENDIX FOR  
TERMINATION DETAILS,  
HARDWARE STYLES,  
POLARIZATION CHART,  
AND PWB PATTERNS**

**RECEPTACLE, PLUG PATTERN, STRAIGHT  
STYLE HGM100 SBE, SDE, SSE, SWE**

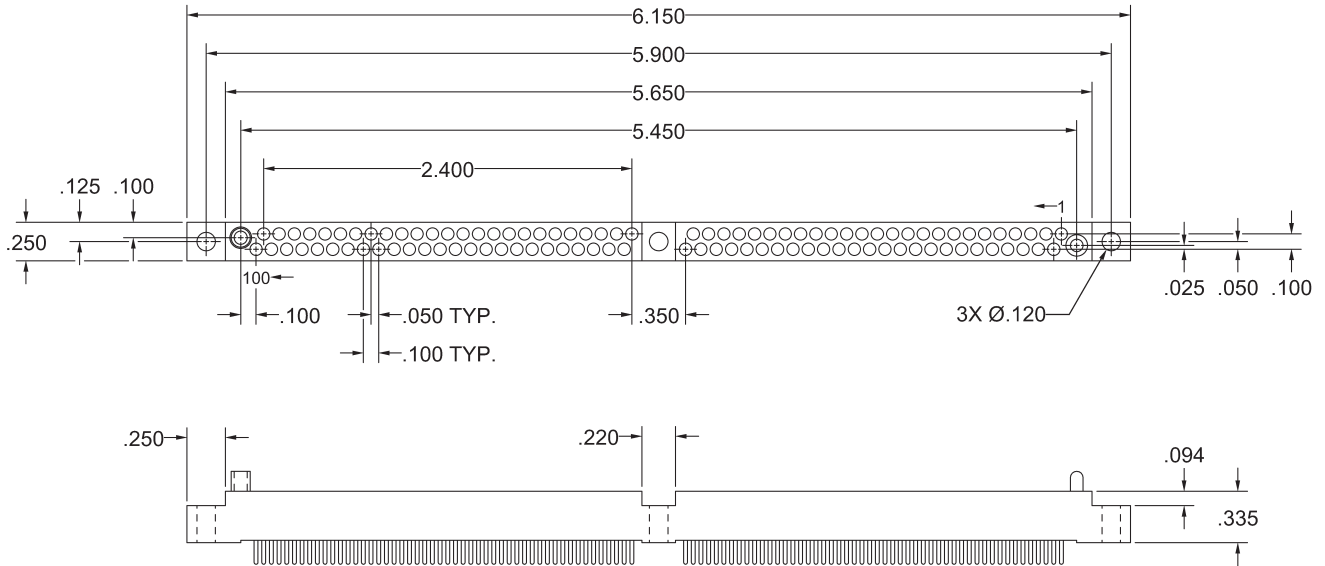

**REFER TO APPENDIX FOR  
TERMINATION DETAILS,  
HARDWARE STYLES,  
POLARIZATION CHART,  
AND PWB PATTERNS**

**RECEPTACLE, PLUG PATTERN, COMPLIANT  
STYLE HGM100 SVE**

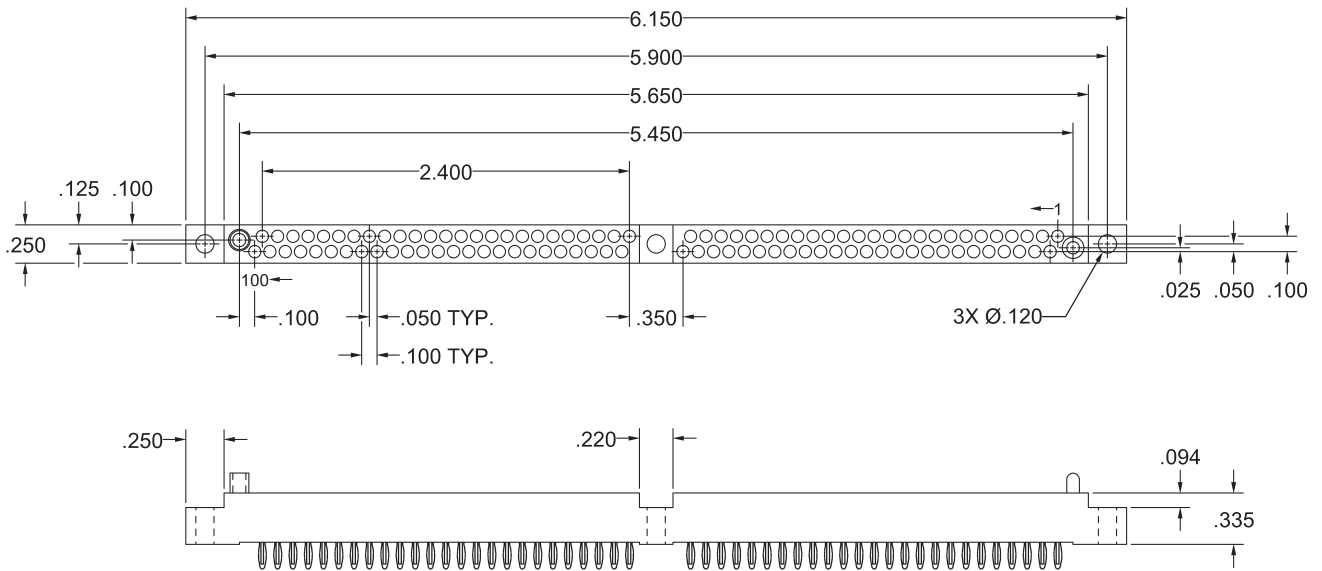

**REFER TO APPENDIX FOR  
TERMINATION DETAILS,  
HARDWARE STYLES,  
POLARIZATION CHART,  
AND PWB PATTERNS**

### PLUG, RECEPTACLE PATTERN, STRAIGHT STYLE HGM100 MBE, MDE, MSE, MWE

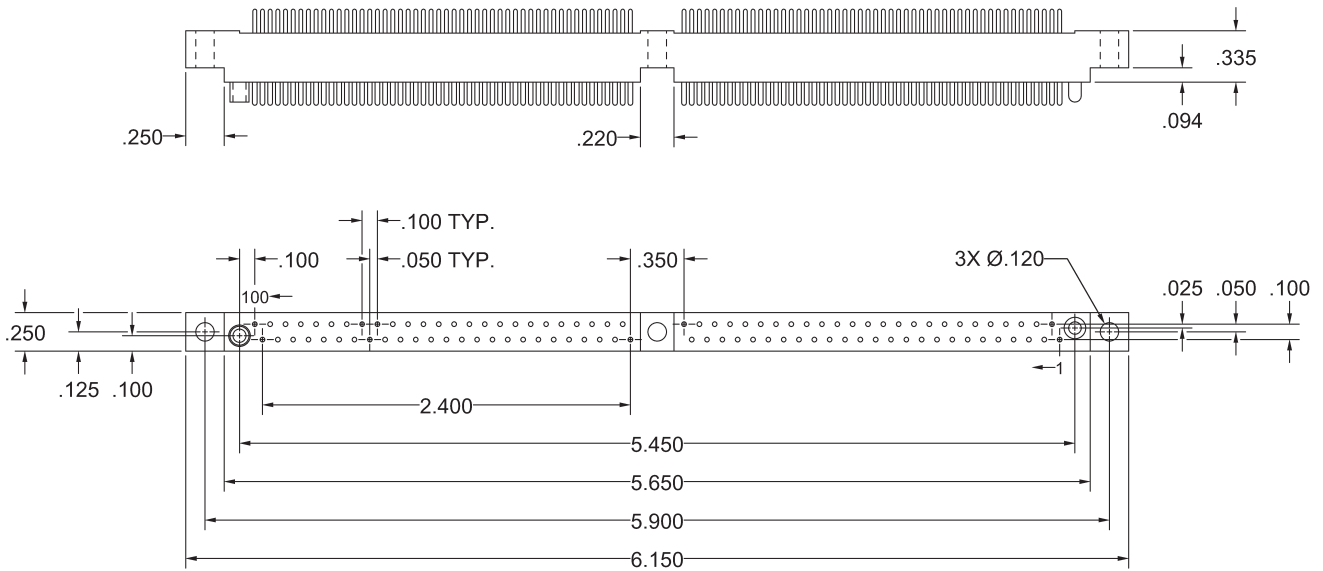

**REFER TO APPENDIX FOR  
TERMINATION DETAILS,  
HARDWARE STYLES,  
POLARIZATION CHART,  
AND PWB PATTERNS**







**PLUG, COMPLIANT  
STYLE HGM100 PVE**

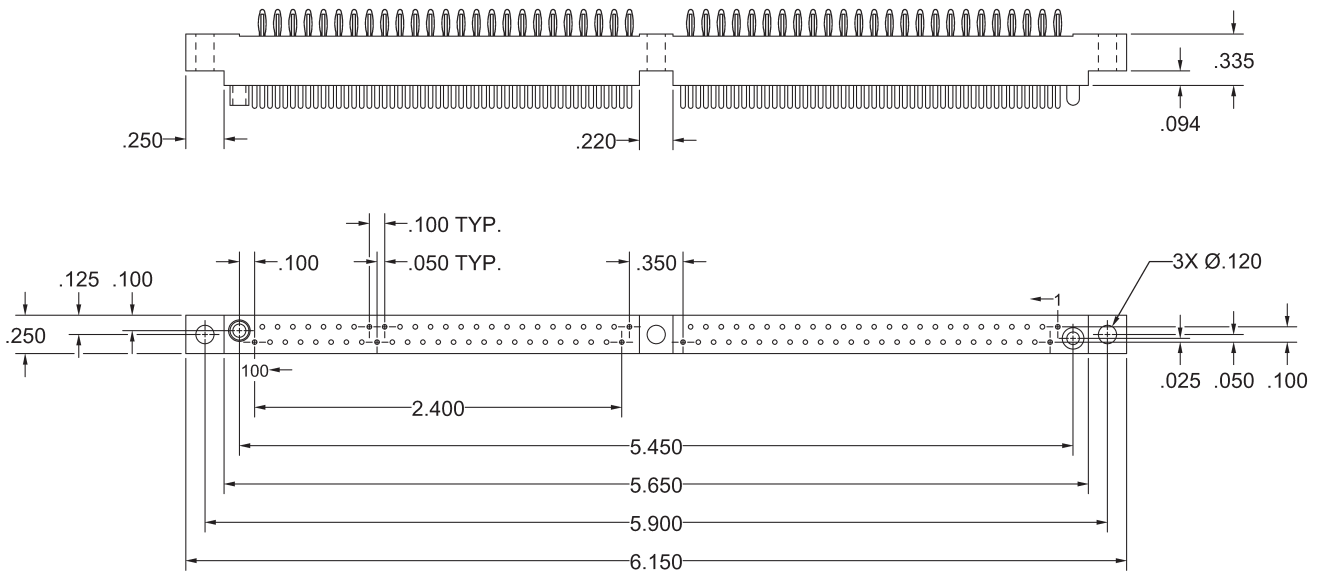

**REFER TO APPENDIX FOR  
TERMINATION DETAILS,  
HARDWARE STYLES,  
POLARIZATION CHART,  
AND PWB PATTERNS**



**RECEPTACLE, RIGHT ANGLE  
STYLE HGM120 FEE**

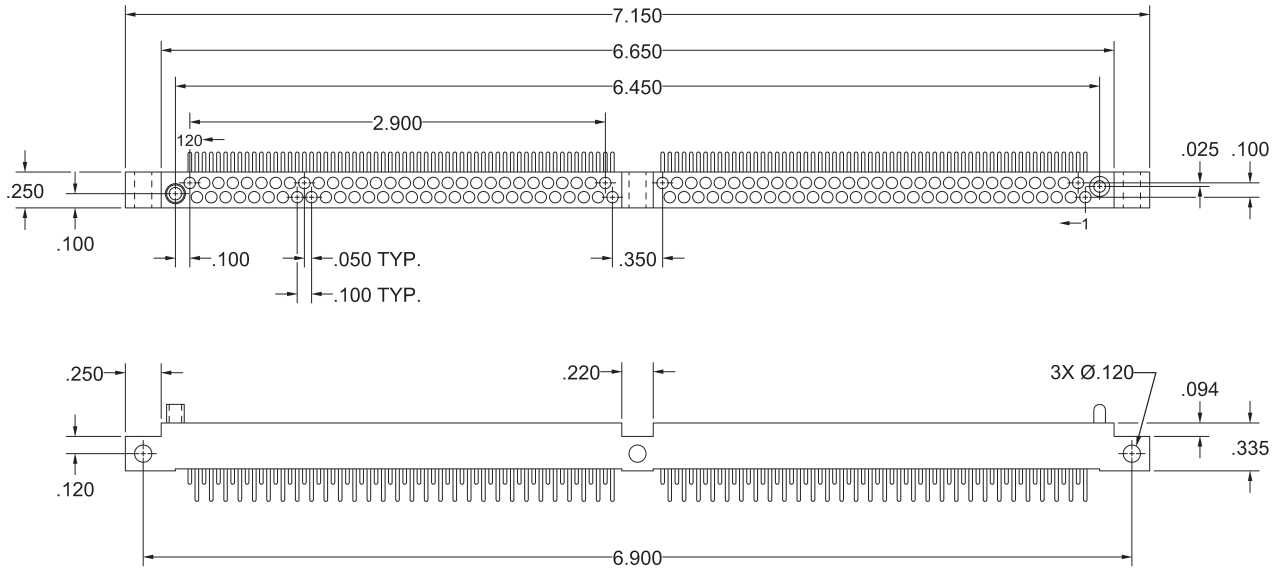

**REFER TO APPENDIX FOR  
TERMINATION DETAILS,  
HARDWARE STYLES,  
POLARIZATION CHART,  
AND PWB PATTERNS**

### RECEPTACLE, SURFACE MOUNT STYLE HGM120 FRE

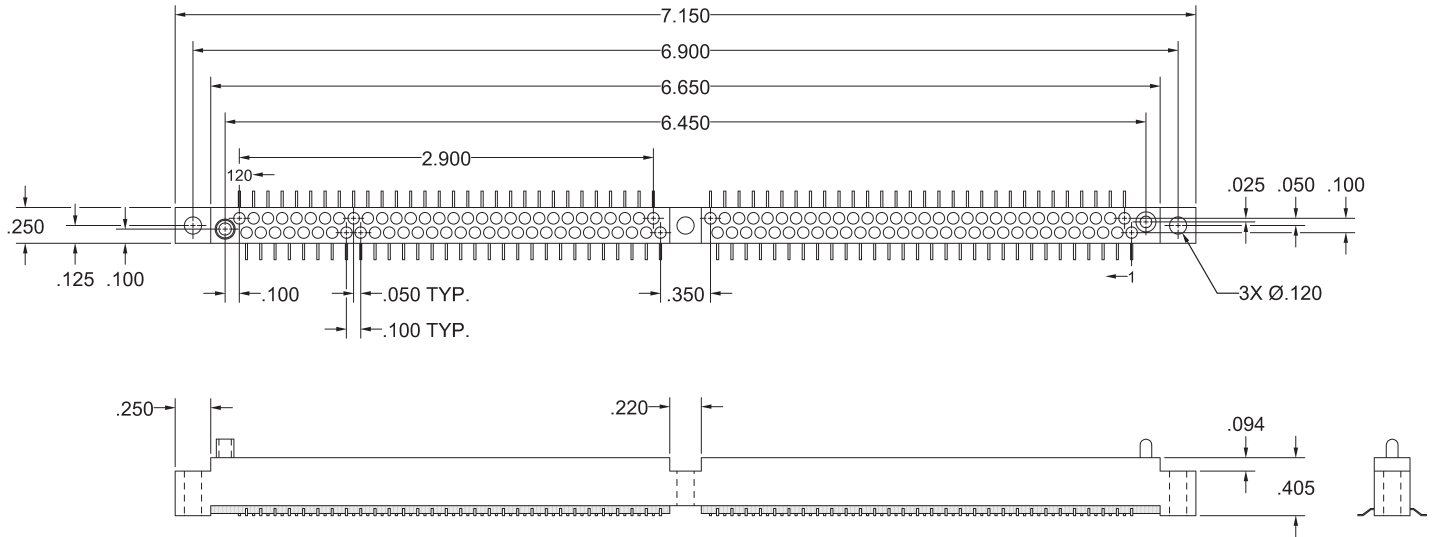

**REFER TO APPENDIX FOR  
TERMINATION DETAILS,  
HARDWARE STYLES,  
POLARIZATION CHART,  
AND PWB PATTERNS**

**RECEPTACLE, COMPLIANT  
STYLE HGM120 FVE**

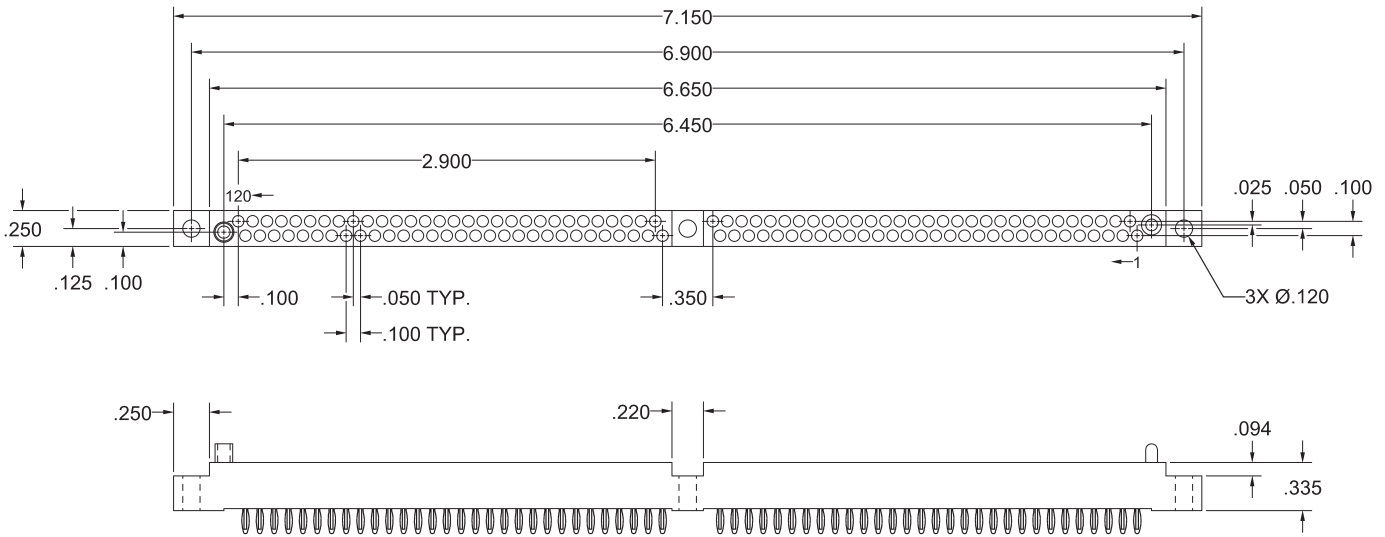

**REFER TO APPENDIX FOR  
TERMINATION DETAILS,  
HARDWARE STYLES,  
POLARIZATION CHART,  
AND PWB PATTERNS**

### PLUG, RIGHT ANGLE STYLE HGM120 MEE

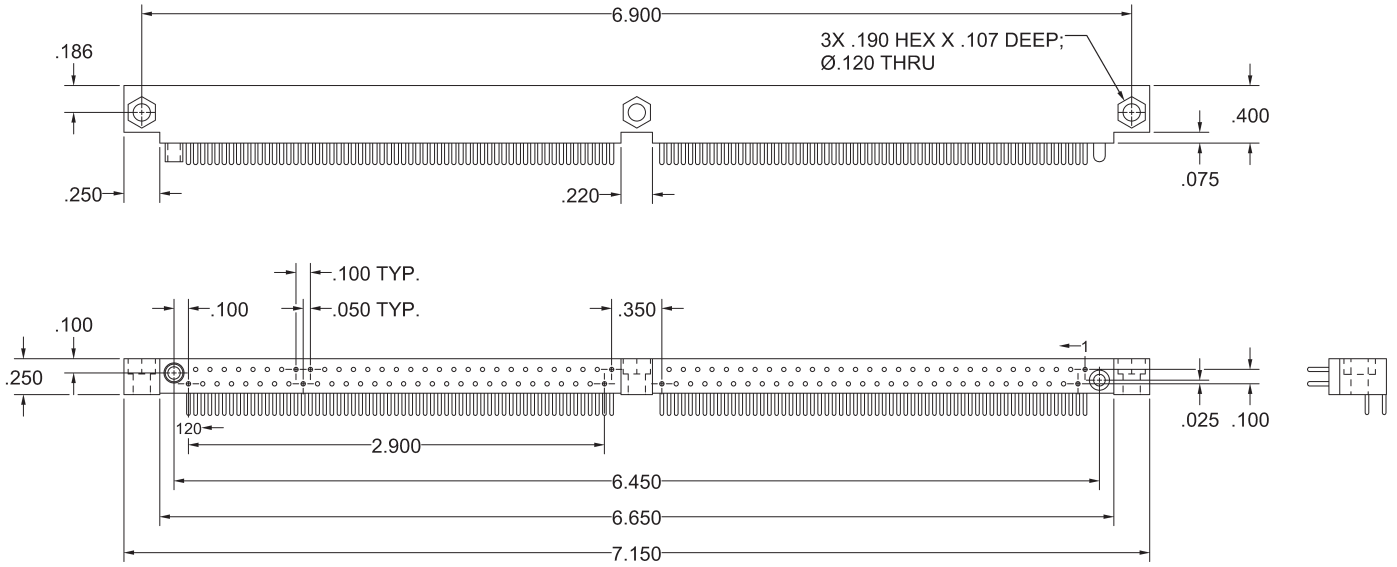

**REFER TO APPENDIX FOR  
TERMINATION DETAILS,  
HARDWARE STYLES,  
POLARIZATION CHART,  
AND PWB PATTERNS**



**PLUG, STRAIGHT  
STYLE HGM120 RBE, RDE, RSE, RWE**

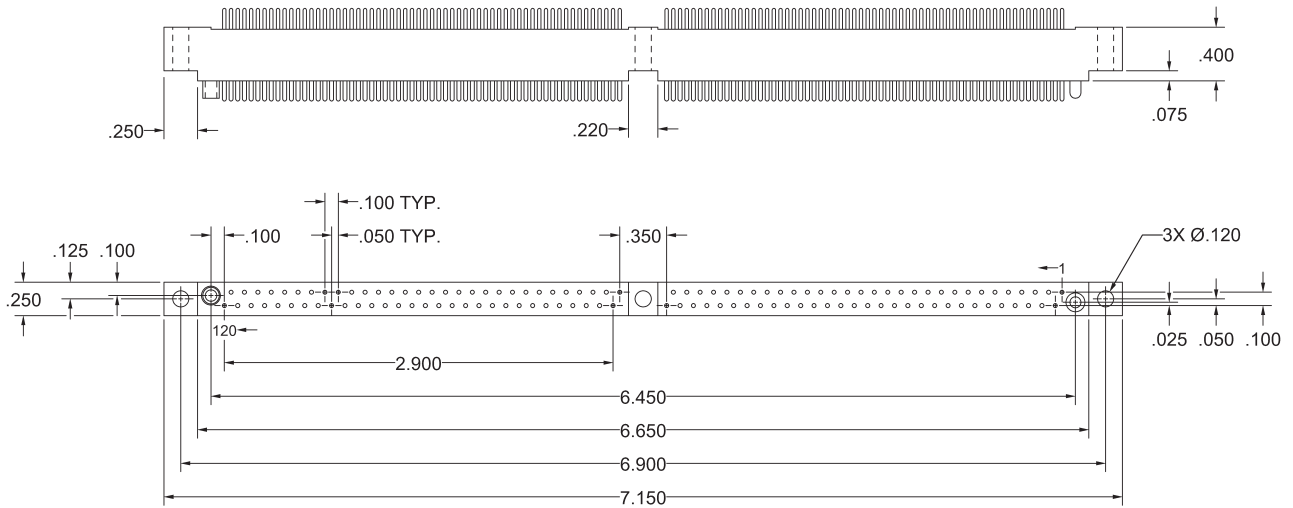

**REFER TO APPENDIX FOR  
TERMINATION DETAILS,  
HARDWARE STYLES,  
POLARIZATION CHART,  
AND PWB PATTERNS**

## ORDERING CHART 3-ROW

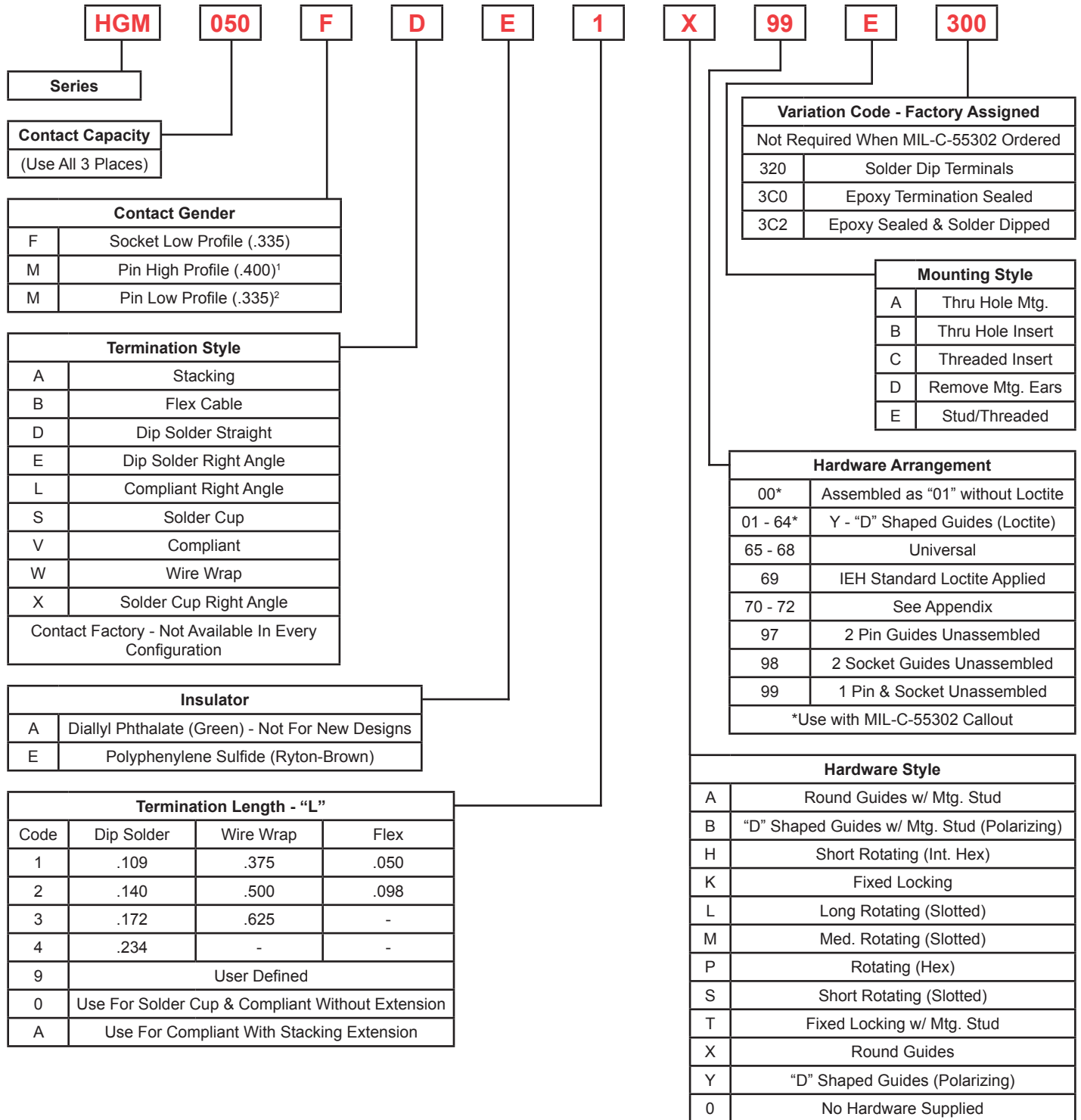
**Notes:**

1. For Termination Style E, X, L.
2. For Termination Style A, B, D, S, V, W

**RECEPTACLE, STACKING  
STYLE FAE9, FVEA**

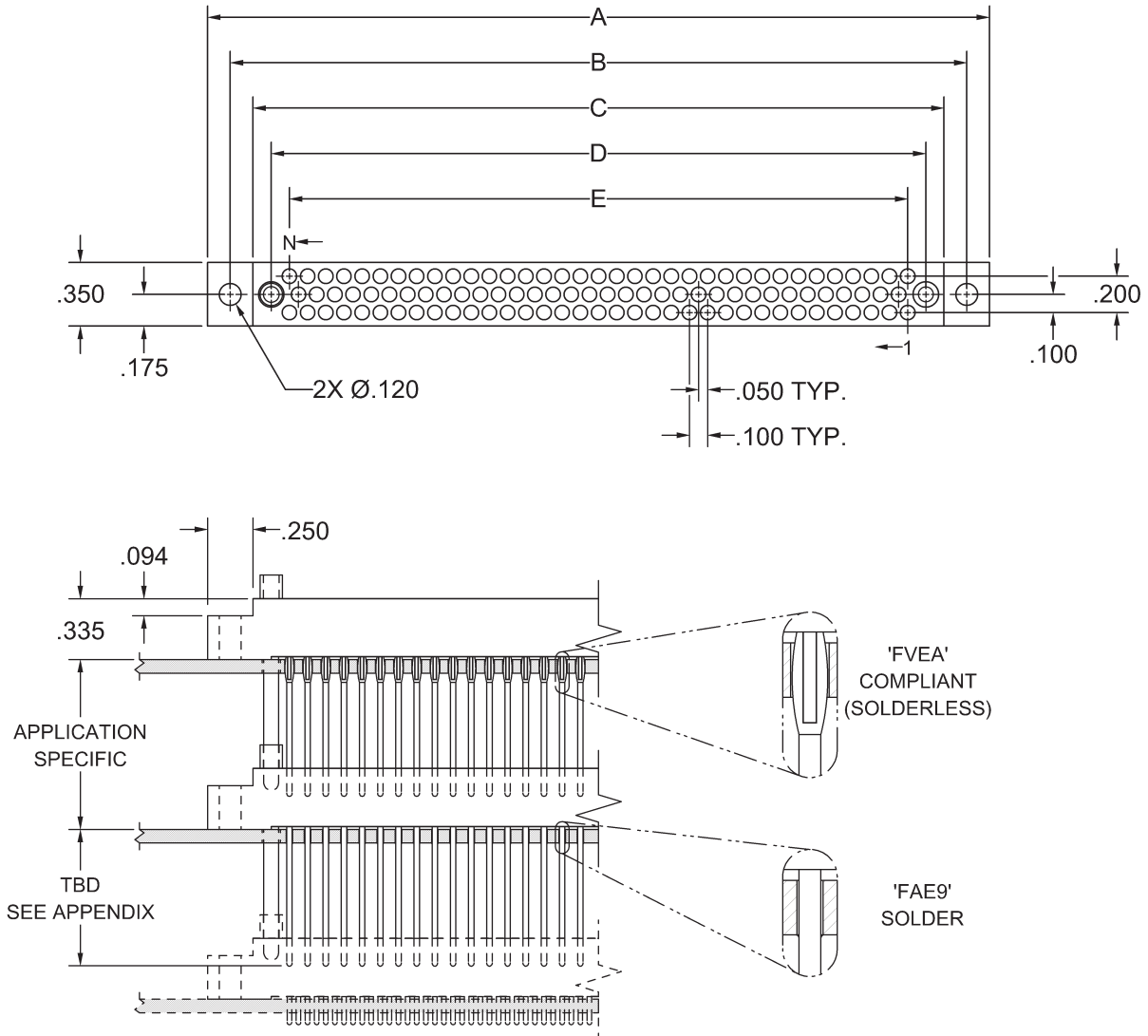

'N' Contacts	A	B	C	D	E
050	2.500	2.250	2.000	1.800	1.600
062	2.900	2.650	2.400	2.200	2.000
080	3.500	3.250	3.000	2.800	2.600
092	3.900	3.650	3.400	3.200	3.000
104	4.300	4.050	3.800	3.600	3.400

**REFER TO APPENDIX FOR  
TERMINATION DETAILS,  
HARDWARE STYLES,  
POLARIZATION CHART,  
AND PWB PATTERNS**

**RECEPTACLE, STRAIGHT  
STYLE FBE, FDE, FSE, FWE**

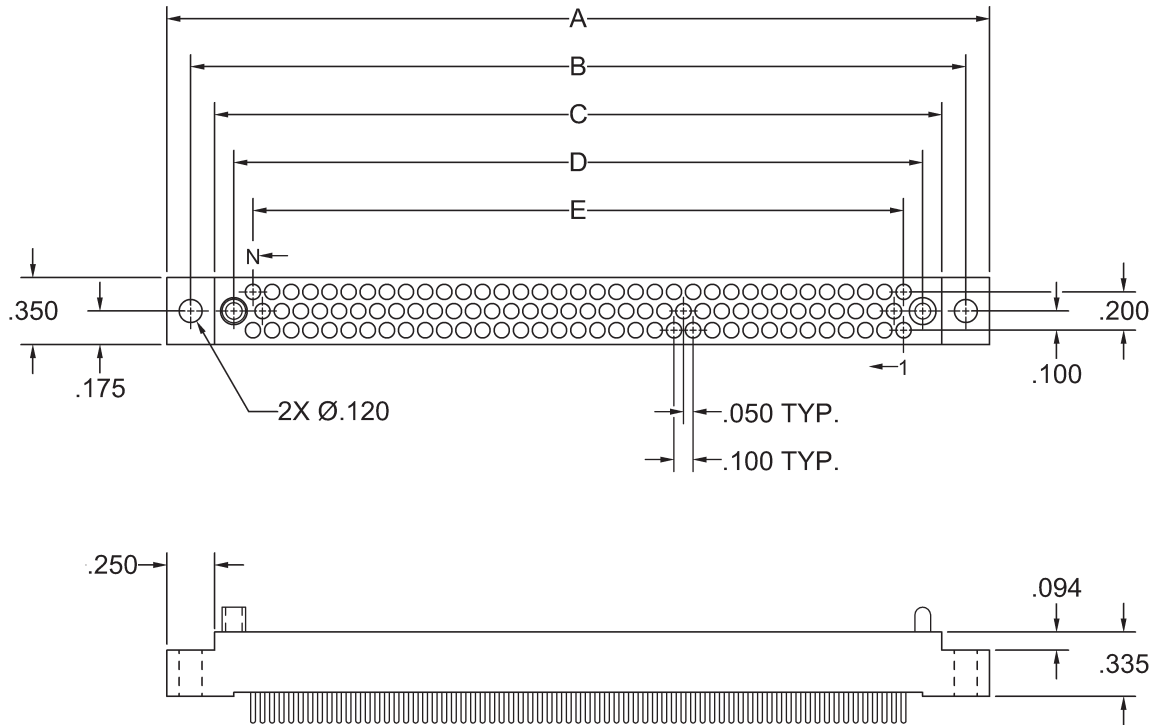

'N' Contacts	A	B	C	D	E
050	2.500	2.250	2.000	1.800	1.600
062	2.900	2.650	2.400	2.200	2.000
080	3.500	3.250	3.000	2.800	2.600
092	3.900	3.650	3.400	3.200	3.000
104	4.300	4.050	3.800	3.600	3.400

**REFER TO APPENDIX FOR  
TERMINATION DETAILS,  
HARDWARE STYLES,  
POLARIZATION CHART,  
AND PWB PATTERNS**

**RECEPTACLE, RIGHT ANGLE  
STYLE FEE**

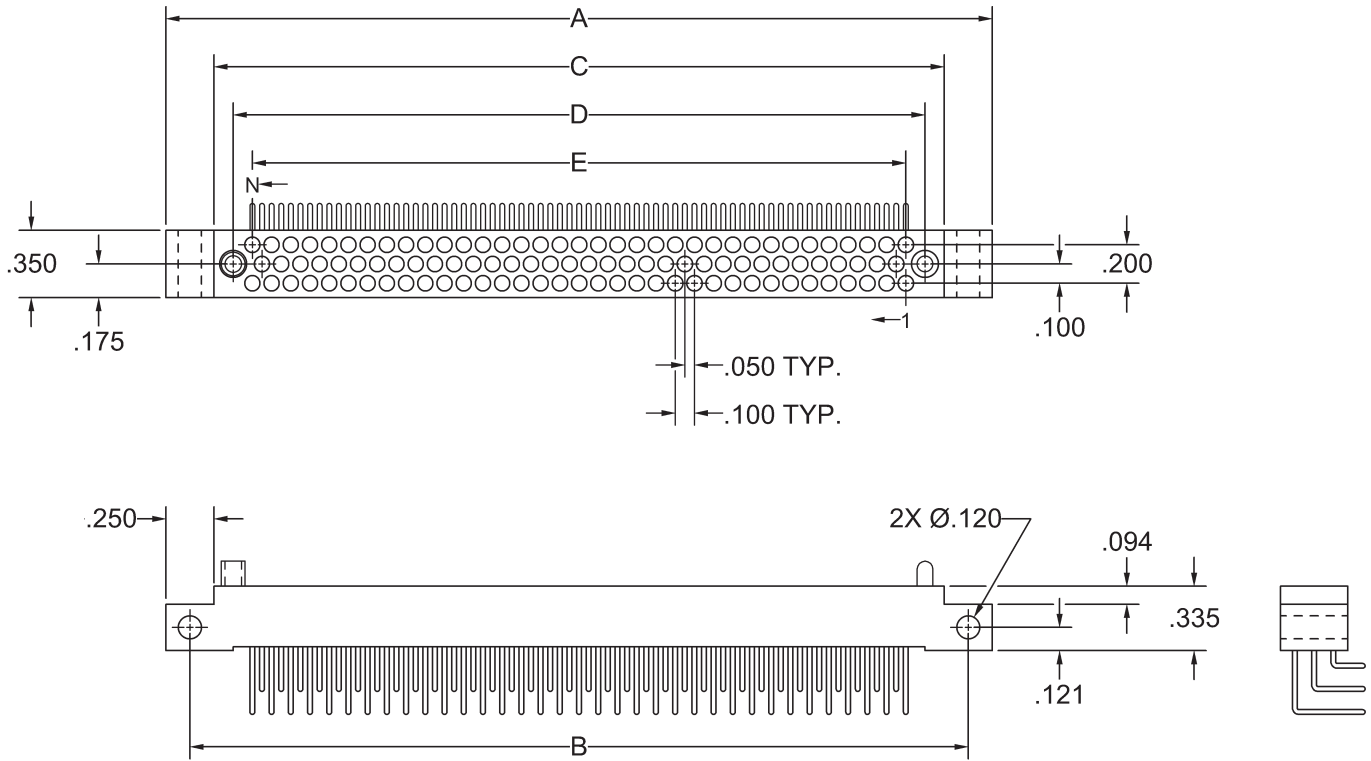

'N' Contacts	A	B	C	D	E
050	2.500	2.250	2.000	1.800	1.600
062	2.900	2.650	2.400	2.200	2.000
080	3.500	3.250	3.000	2.800	2.600
092	3.900	3.650	3.400	3.200	3.000
104	4.300	4.050	3.800	3.600	3.400

**REFER TO APPENDIX FOR  
TERMINATION DETAILS,  
HARDWARE STYLES,  
POLARIZATION CHART,  
AND PWB PATTERNS**

**RECEPTACLE, COMPLIANT  
STYLE FVE**

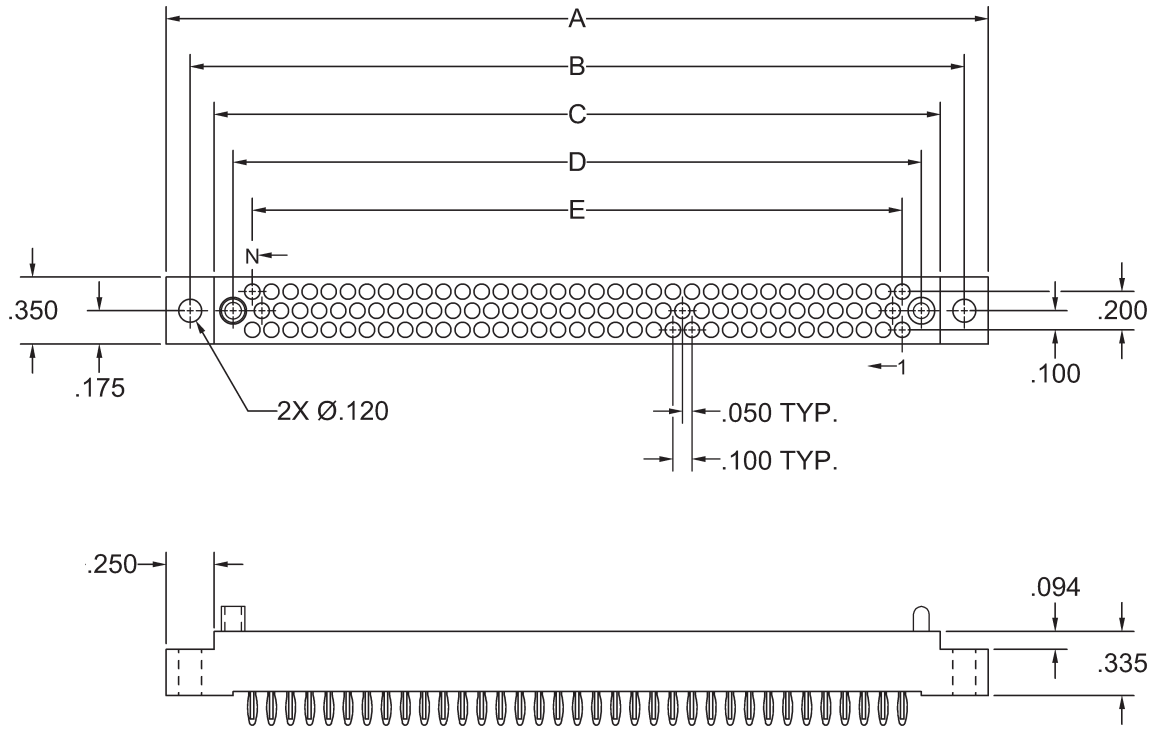

'N' Contacts	A	B	C	D	E
050	2.500	2.250	2.000	1.800	1.600
062	2.900	2.650	2.400	2.200	2.000
080	3.500	3.250	3.000	2.800	2.600
092	3.900	3.650	3.400	3.200	3.000
104	4.300	4.050	3.800	3.600	3.400

**REFER TO APPENDIX FOR  
TERMINATION DETAILS,  
HARDWARE STYLES,  
POLARIZATION CHART,  
AND PWB PATTERNS**

**PLUG, STACKING  
STYLE MAE9, MVEA**

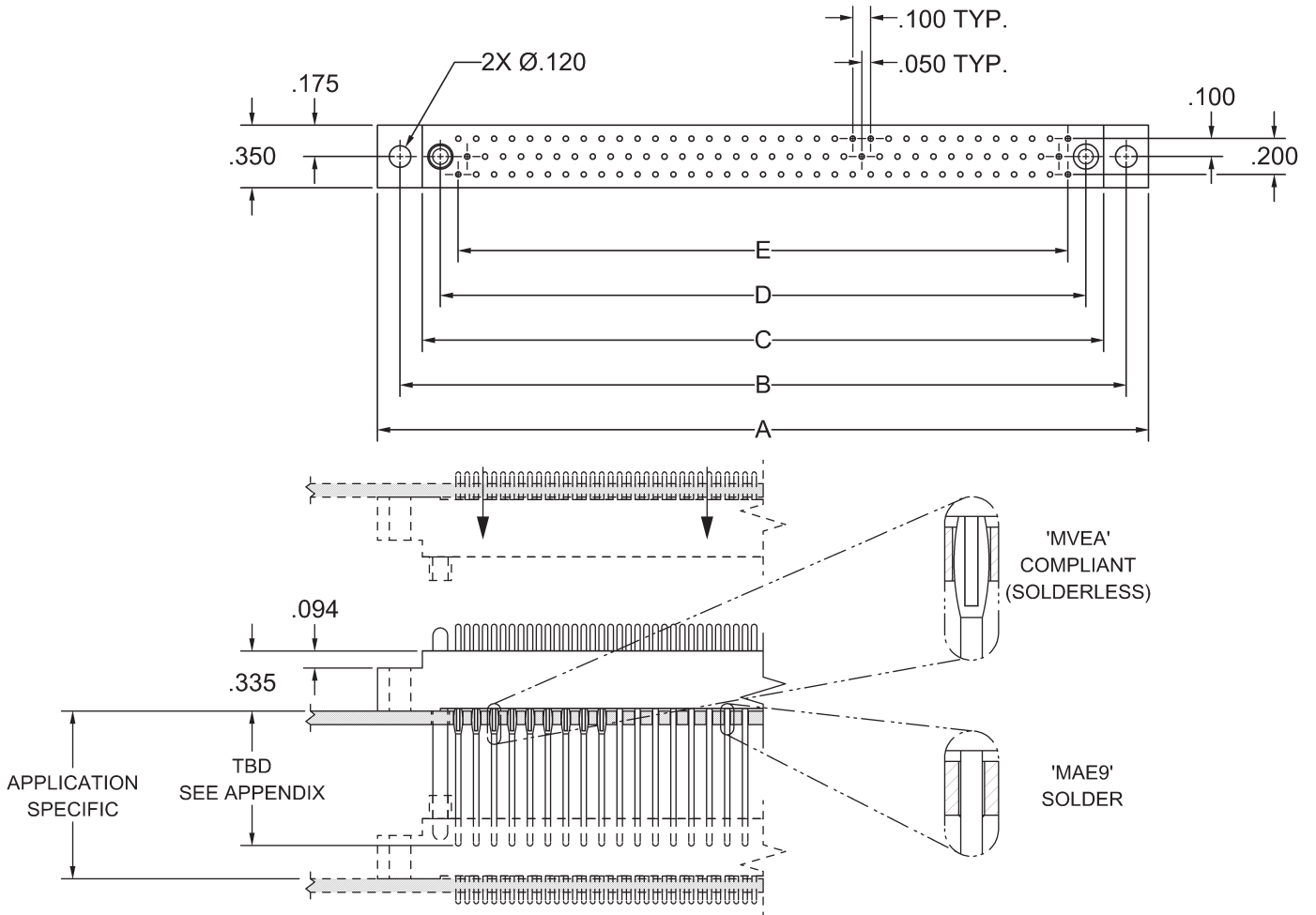

'N' Contacts	A	B	C	D	E
050	2.500	2.250	2.000	1.800	1.600
062	2.900	2.650	2.400	2.200	2.000
080	3.500	3.250	3.000	2.800	2.600
092	3.900	3.650	3.400	3.200	3.000
104	4.300	4.050	3.800	3.600	3.400

**REFER TO APPENDIX FOR  
TERMINATION DETAILS,  
HARDWARE STYLES,  
POLARIZATION CHART,  
AND PWB PATTERNS**

**PLUG, STRAIGHT  
STYLE MBE, MDE, MSE, MWE**

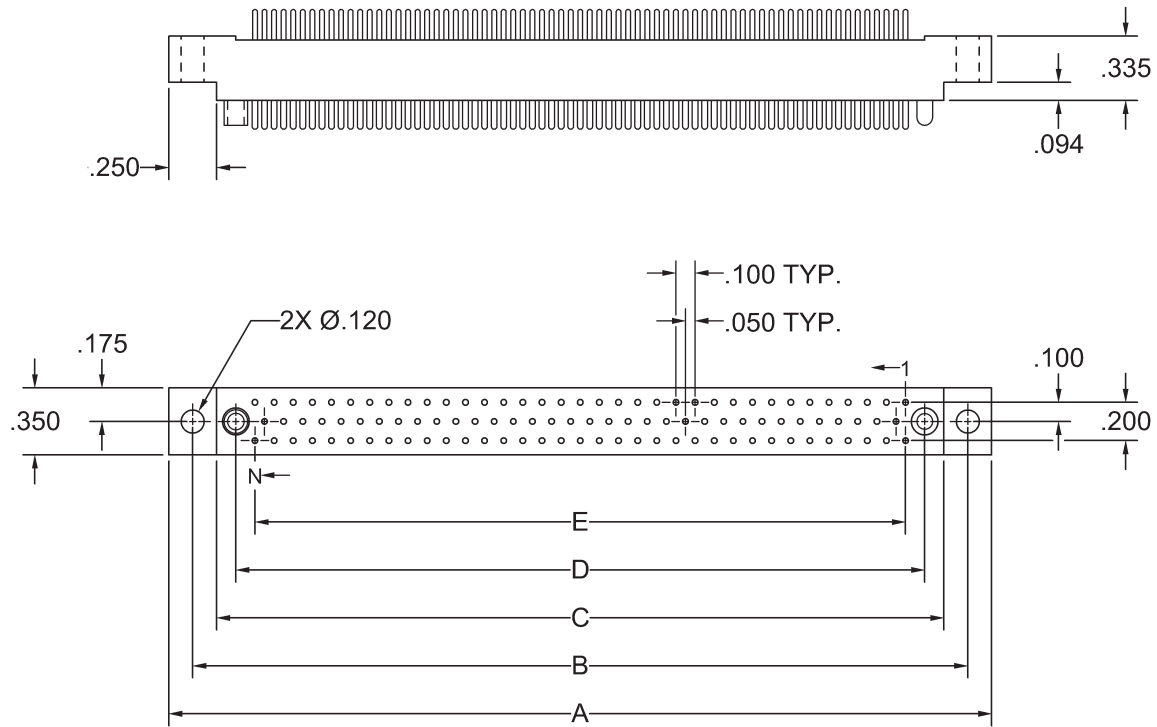

'N' Contacts	A	B	C	D	E
050	2.500	2.250	2.000	1.800	1.600
062	2.900	2.650	2.400	2.200	2.000
080	3.500	3.250	3.000	2.800	2.600
092	3.900	3.650	3.400	3.200	3.000
104	4.300	4.050	3.800	3.600	3.400

**REFER TO APPENDIX FOR  
TERMINATION DETAILS,  
HARDWARE STYLES,  
POLARIZATION CHART,  
AND PWB PATTERNS**



**PLUG, RIGHT ANGLE  
STYLE MEE, MLE, MXE**

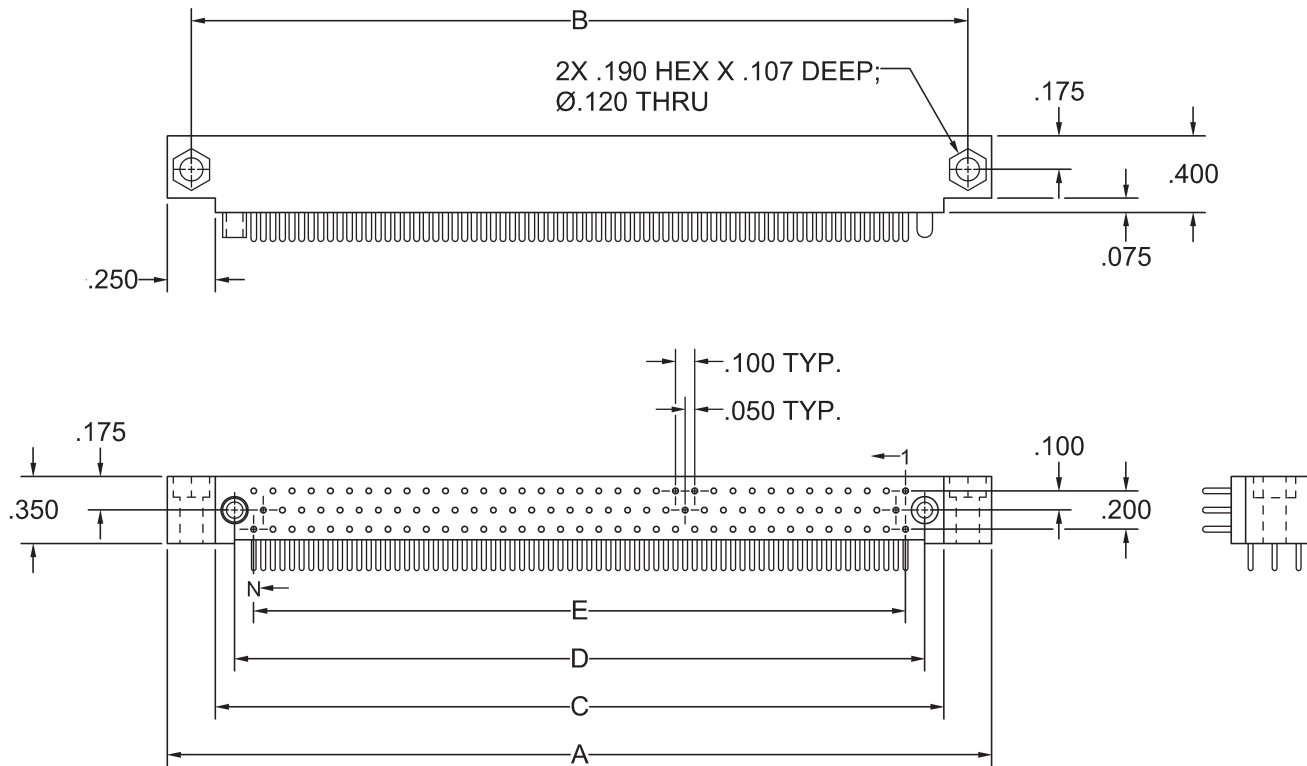

'N' Contacts	A	B	C	D	E
050	2.500	2.250	2.000	1.800	1.600
062	2.900	2.650	2.400	2.200	2.000
080	3.500	3.250	3.000	2.800	2.600
092	3.900	3.650	3.400	3.200	3.000
104	4.300	4.050	3.800	3.600	3.400

**REFER TO APPENDIX FOR  
TERMINATION DETAILS,  
HARDWARE STYLES,  
POLARIZATION CHART,  
AND PWB PATTERNS**

**PLUG, COMPLIANT  
STYLE MVE**

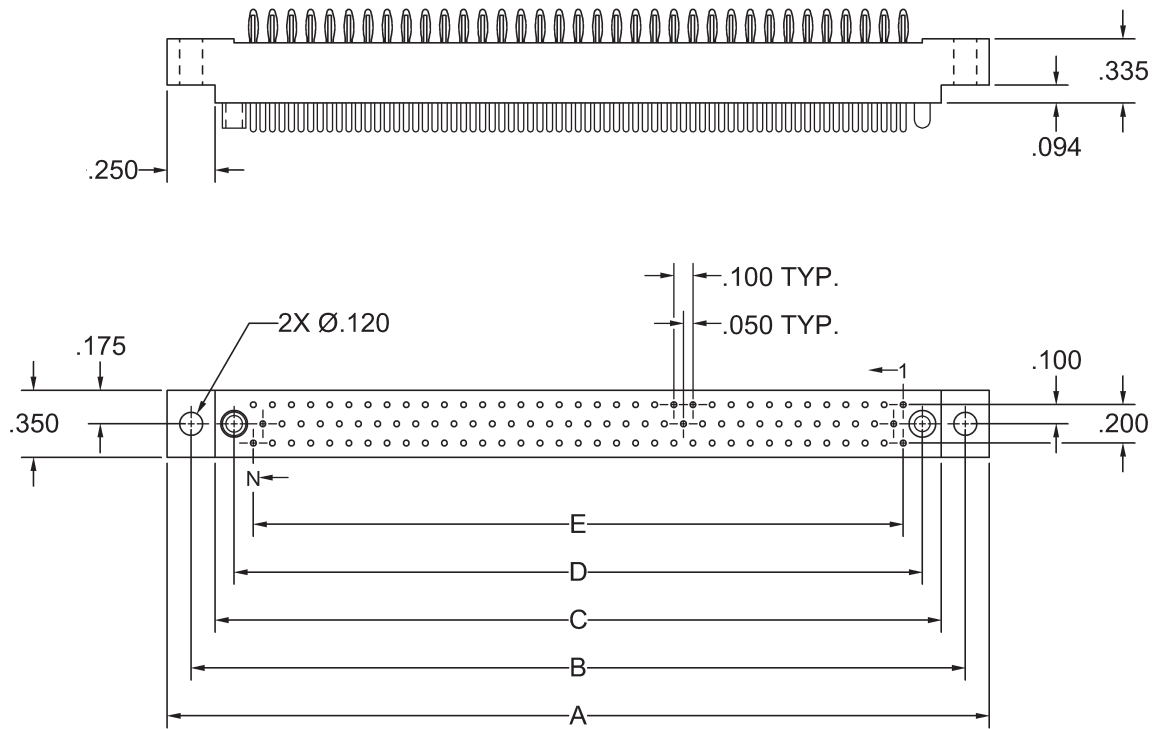

'N' Contacts	A	B	C	D	E
050	2.500	2.250	2.000	1.800	1.600
062	2.900	2.650	2.400	2.200	2.000
080	3.500	3.250	3.000	2.800	2.600
092	3.900	3.650	3.400	3.200	3.000
104	4.300	4.050	3.800	3.600	3.400

**REFER TO APPENDIX FOR  
TERMINATION DETAILS,  
HARDWARE STYLES,  
POLARIZATION CHART,  
AND PWB PATTERNS**

**RECEPTACLE, STACKING  
STYLE HGM122 FAE9, FVEA**

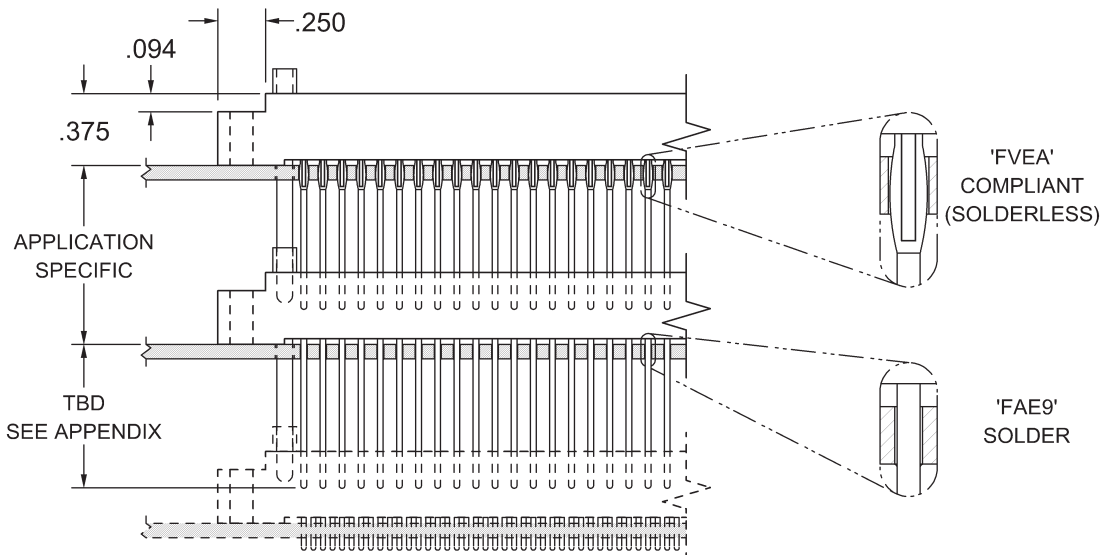
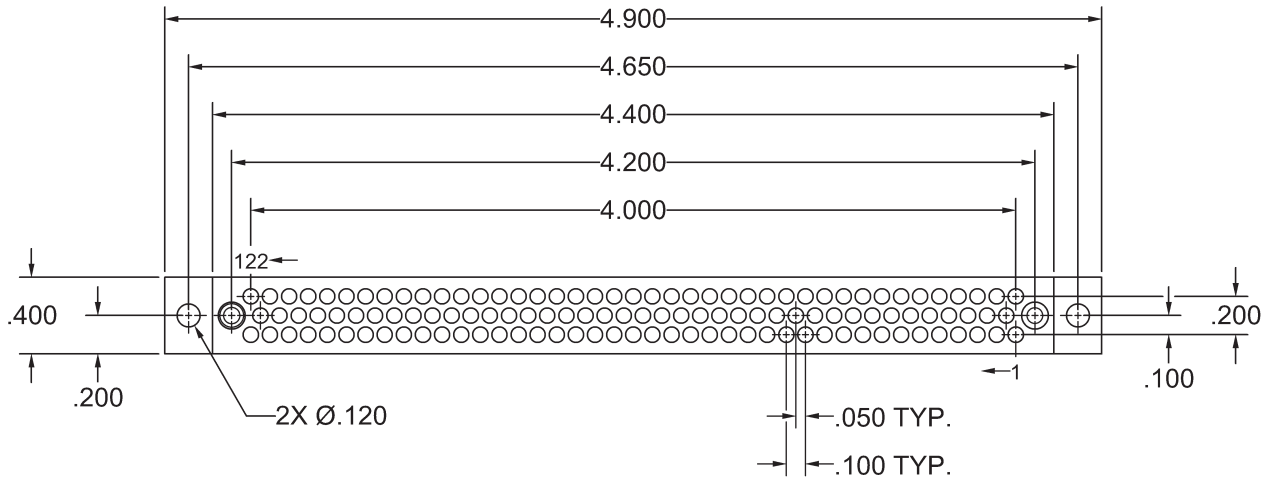

**REFER TO APPENDIX FOR  
TERMINATION DETAILS,  
HARDWARE STYLES,  
POLARIZATION CHART,  
AND PWB PATTERNS**

**RECEPTACLE, STRAIGHT  
STYLE HGM122 FBE, FDE, FSE, FWE**

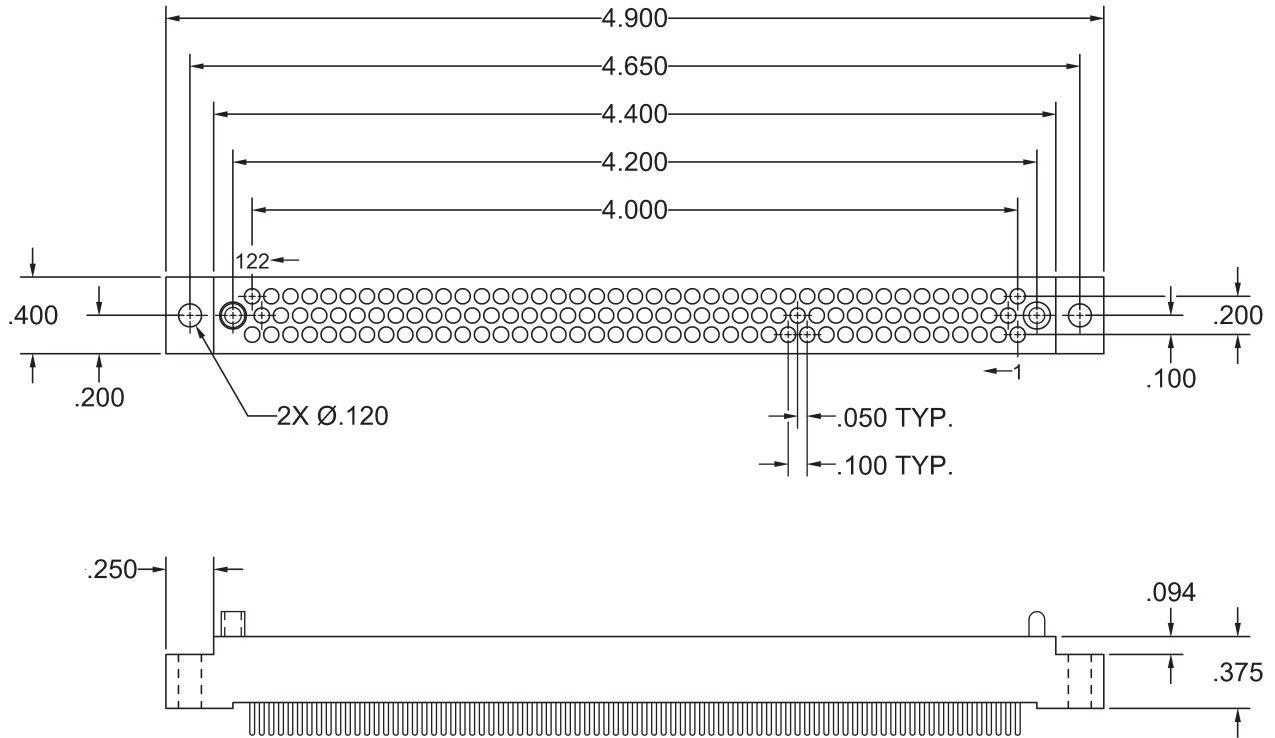

**REFER TO APPENDIX FOR  
TERMINATION DETAILS,  
HARDWARE STYLES,  
POLARIZATION CHART,  
AND PWB PATTERNS**

**RECEPTACLE, RIGHT ANGLE  
STYLE HGM122 FEE**

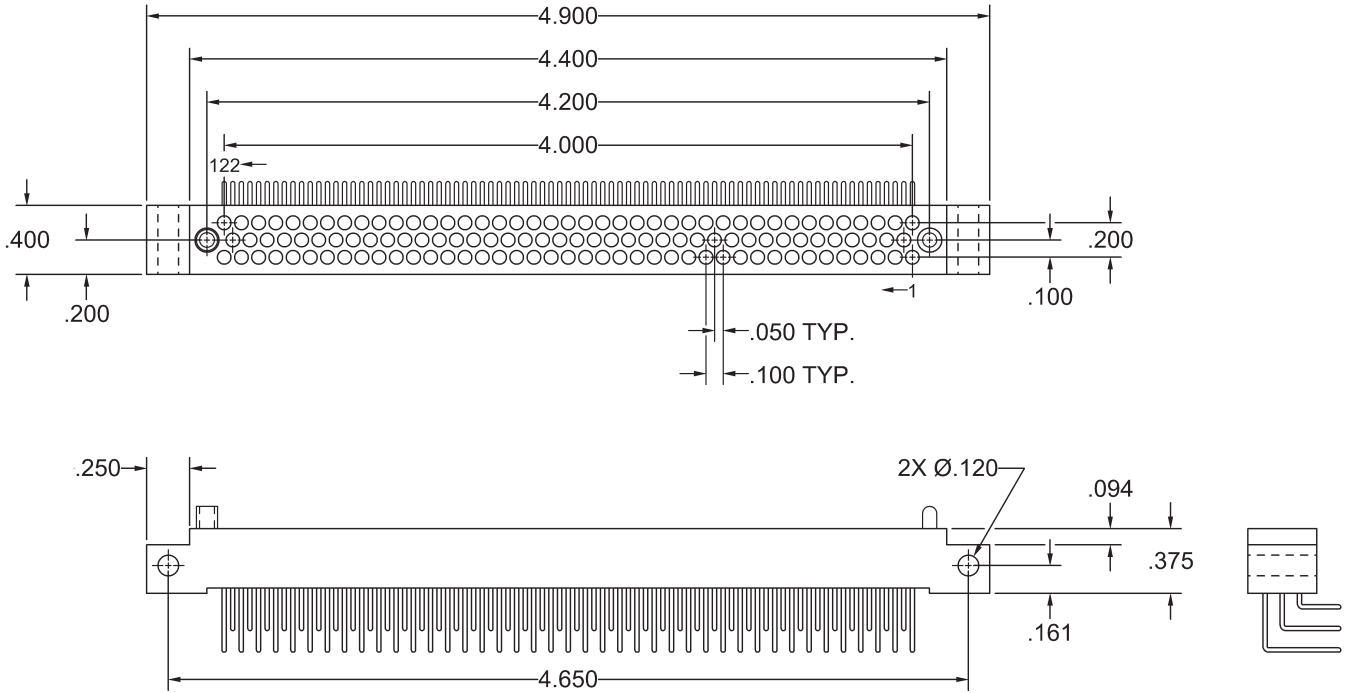

**REFER TO APPENDIX FOR  
TERMINATION DETAILS,  
HARDWARE STYLES,  
POLARIZATION CHART,  
AND PWB PATTERNS**

### RECEPTACLE, COMPLIANT STYLE HGM122 FVE

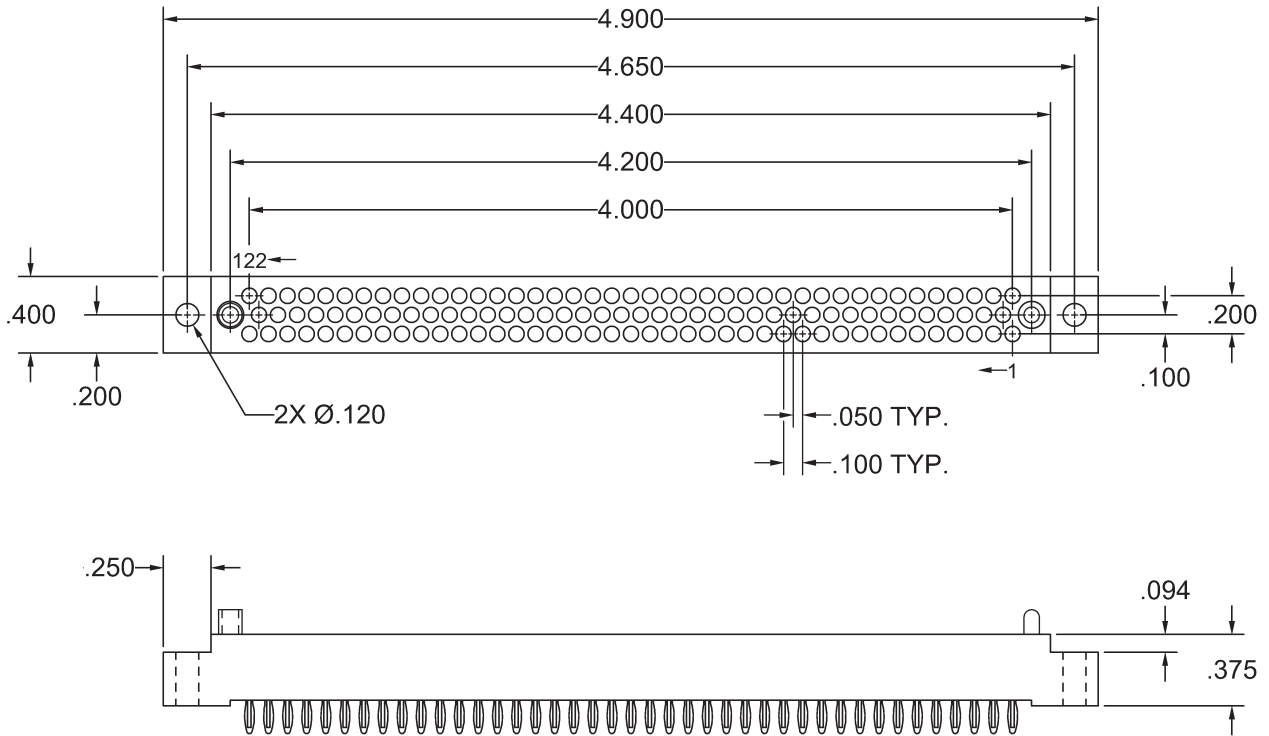

**REFER TO APPENDIX FOR  
TERMINATION DETAILS,  
HARDWARE STYLES,  
POLARIZATION CHART,  
AND PWB PATTERNS**

**PLUG, STACKING  
STYLE HGM122 MAE9, MVEA**

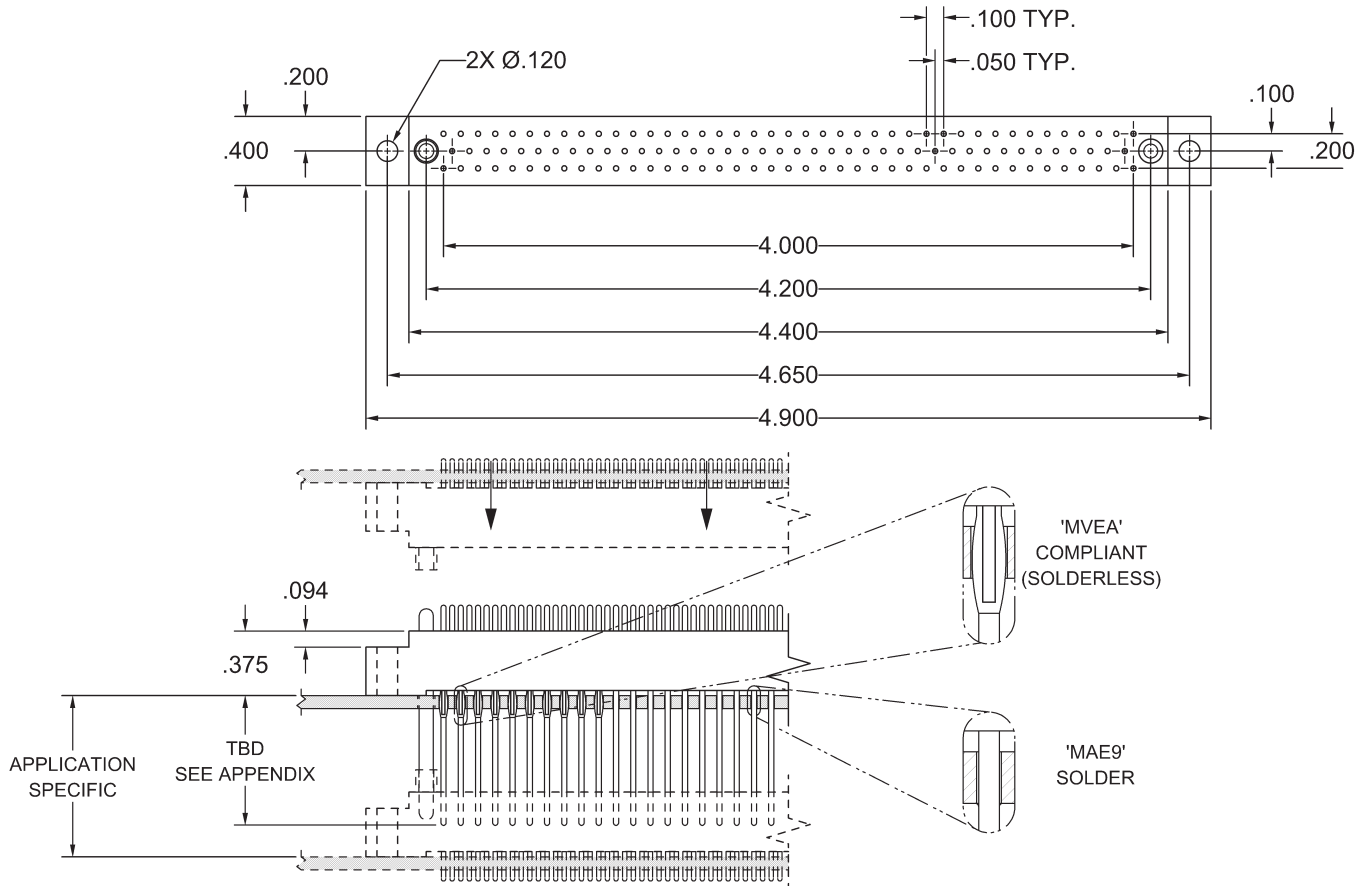

**REFER TO APPENDIX FOR  
TERMINATION DETAILS,  
HARDWARE STYLES,  
POLARIZATION CHART,  
AND PWB PATTERNS**





**PLUG, RIGHT ANGLE  
STYLE HGM122 MEE, MLE, MXE**

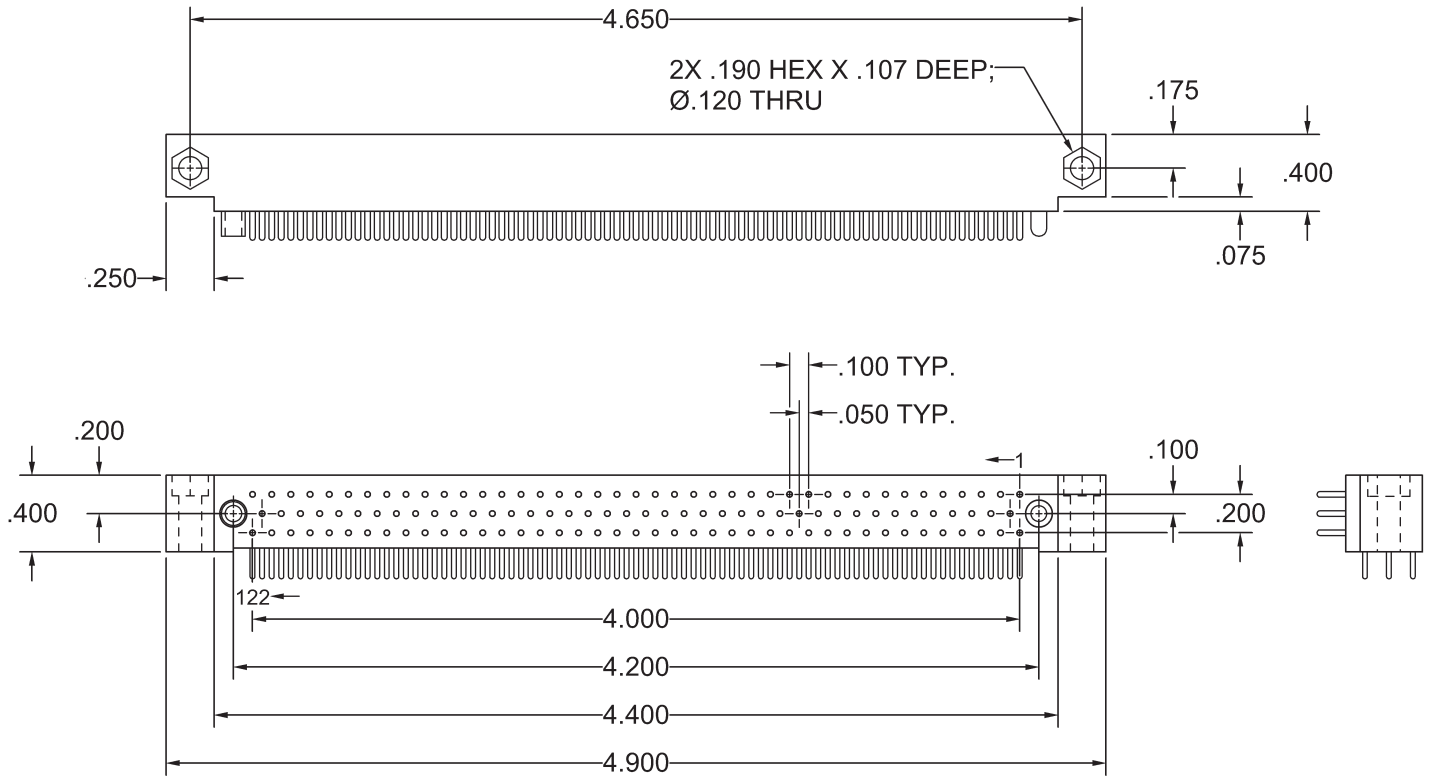

**REFER TO APPENDIX FOR  
TERMINATION DETAILS,  
HARDWARE STYLES,  
POLARIZATION CHART,  
AND PWB PATTERNS**

### PLUG, COMPLIANT STYLE HGM122 MVE

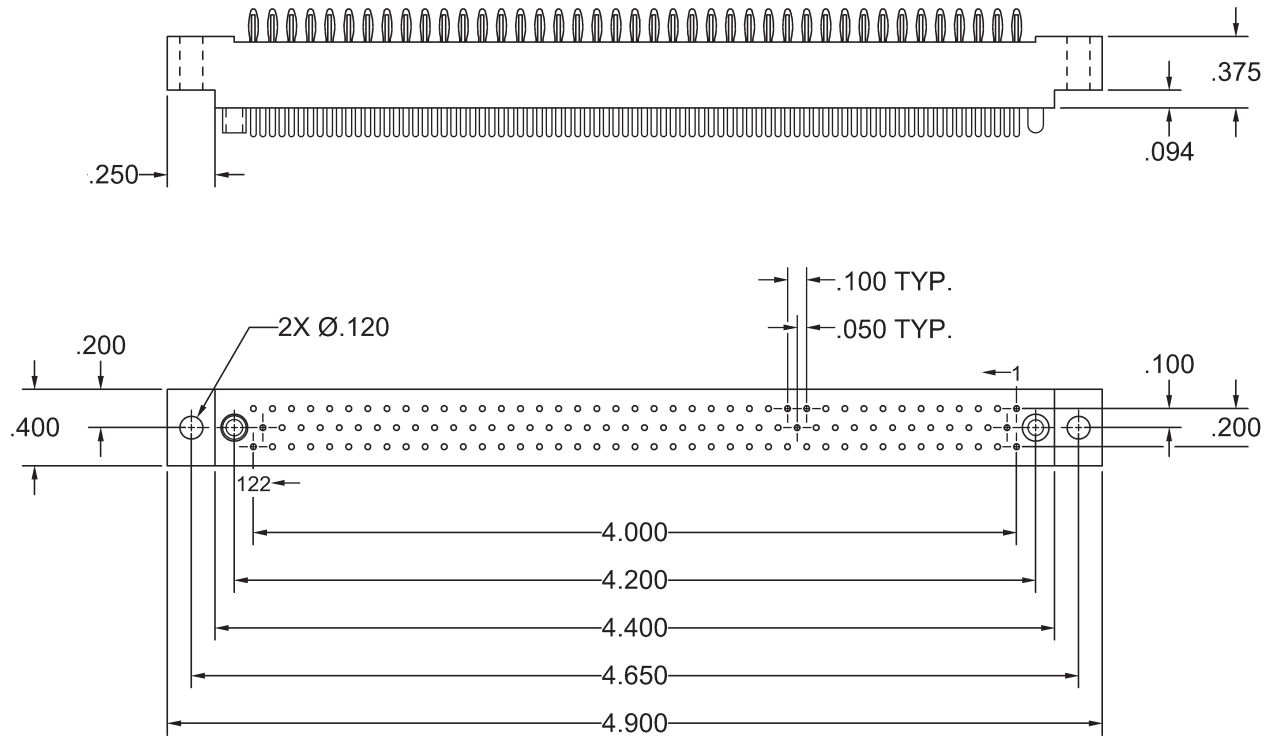

**REFER TO APPENDIX FOR  
TERMINATION DETAILS,  
HARDWARE STYLES,  
POLARIZATION CHART,  
AND PWB PATTERNS**

**RECEPTACLE, STACKING  
STYLE HGM160 FAE9, FVEA**

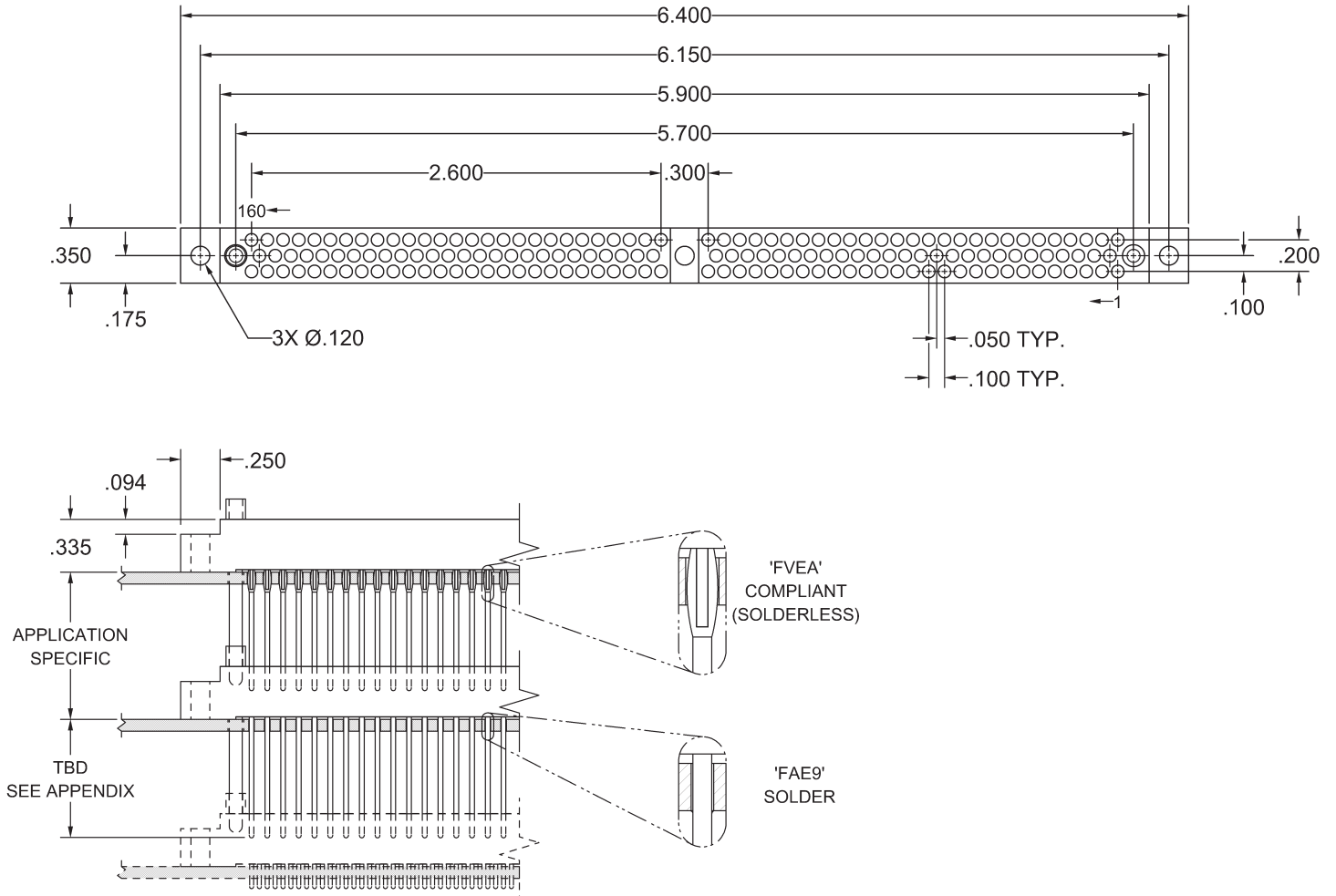

**REFER TO APPENDIX FOR  
TERMINATION DETAILS,  
HARDWARE STYLES,  
POLARIZATION CHART,  
AND PWB PATTERNS**

**RECEPTACLE, STRAIGHT  
STYLE HGM160 FBE, FDE, FSE, FWE**

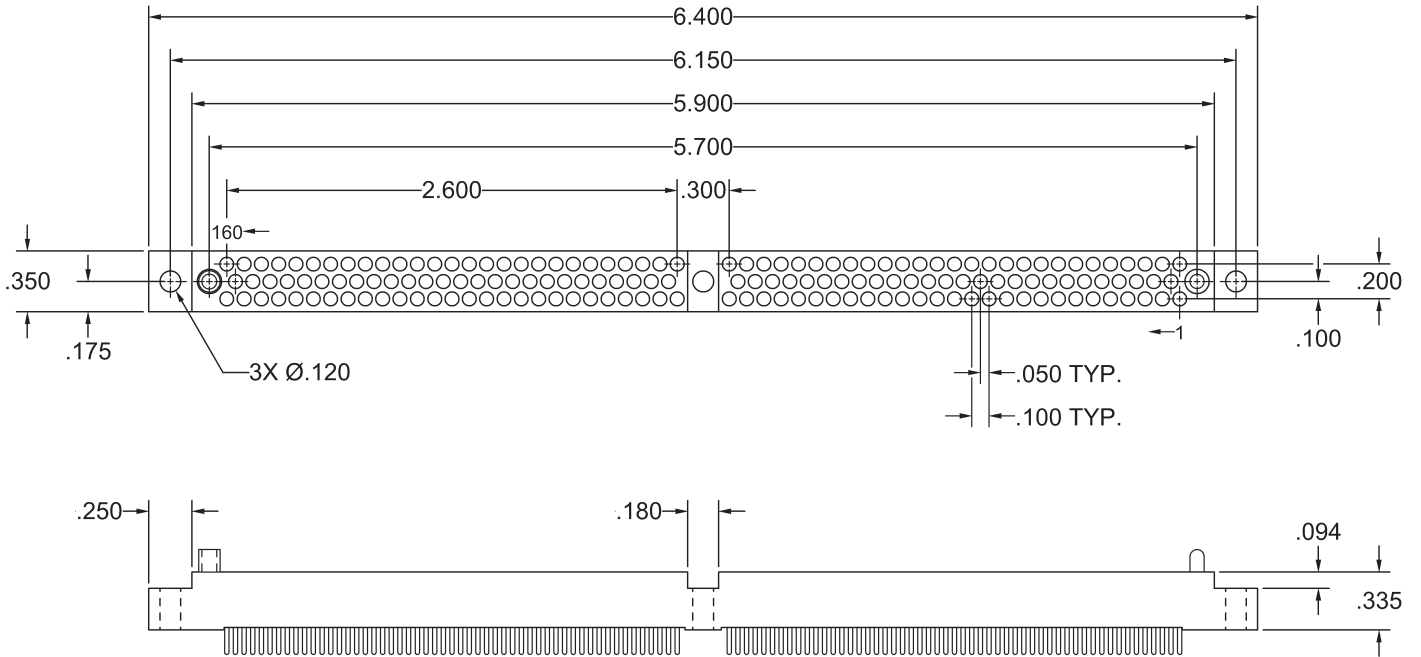

**REFER TO APPENDIX FOR  
TERMINATION DETAILS,  
HARDWARE STYLES,  
POLARIZATION CHART,  
AND PWB PATTERNS**

### RECEPTACLE, RIGHT ANGLE STYLE HGM160 FEE

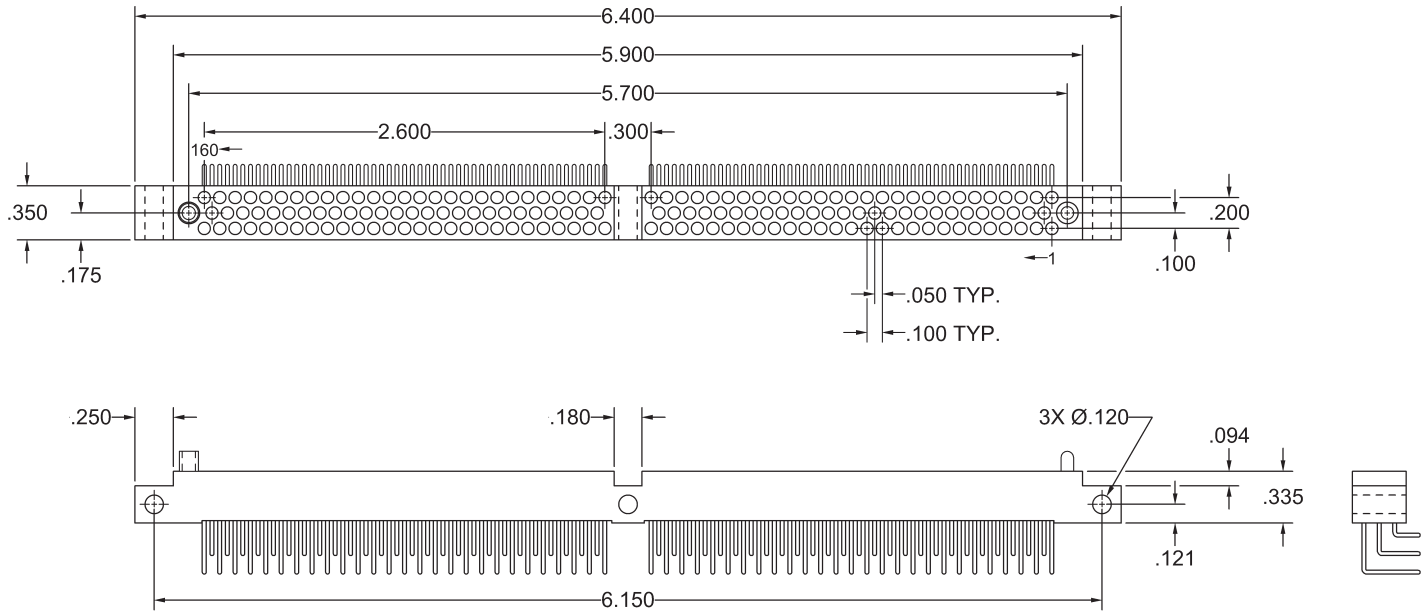

**REFER TO APPENDIX FOR  
TERMINATION DETAILS,  
HARDWARE STYLES,  
POLARIZATION CHART,  
AND PWB PATTERNS**



### PLUG, STACKING STYLE HGM160 MAE9, MVEA

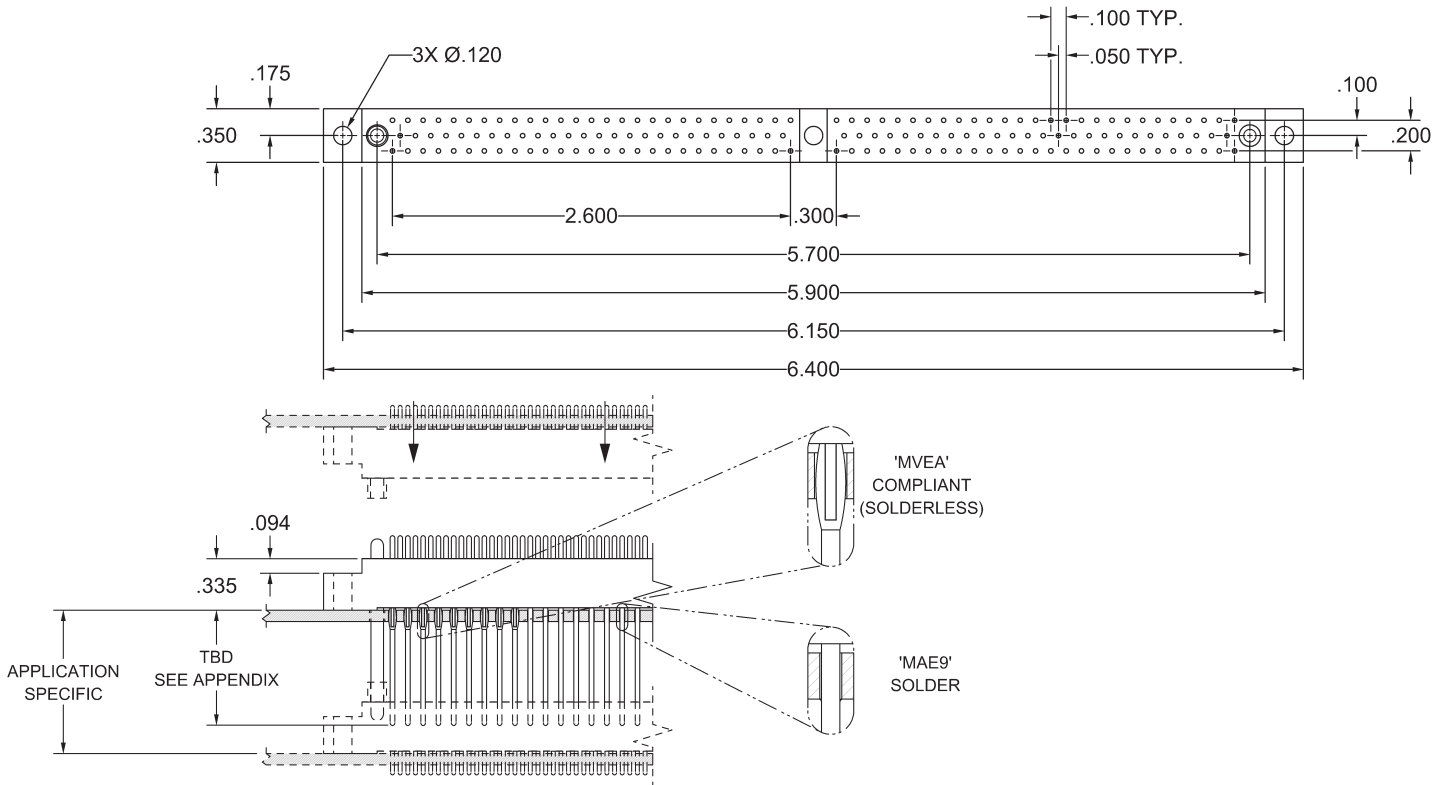

**REFER TO APPENDIX FOR  
TERMINATION DETAILS,  
HARDWARE STYLES,  
POLARIZATION CHART,  
AND PWB PATTERNS**

**PLUG, STRAIGHT  
STYLE HGM160 MBE, MDE, MSE, MWE**

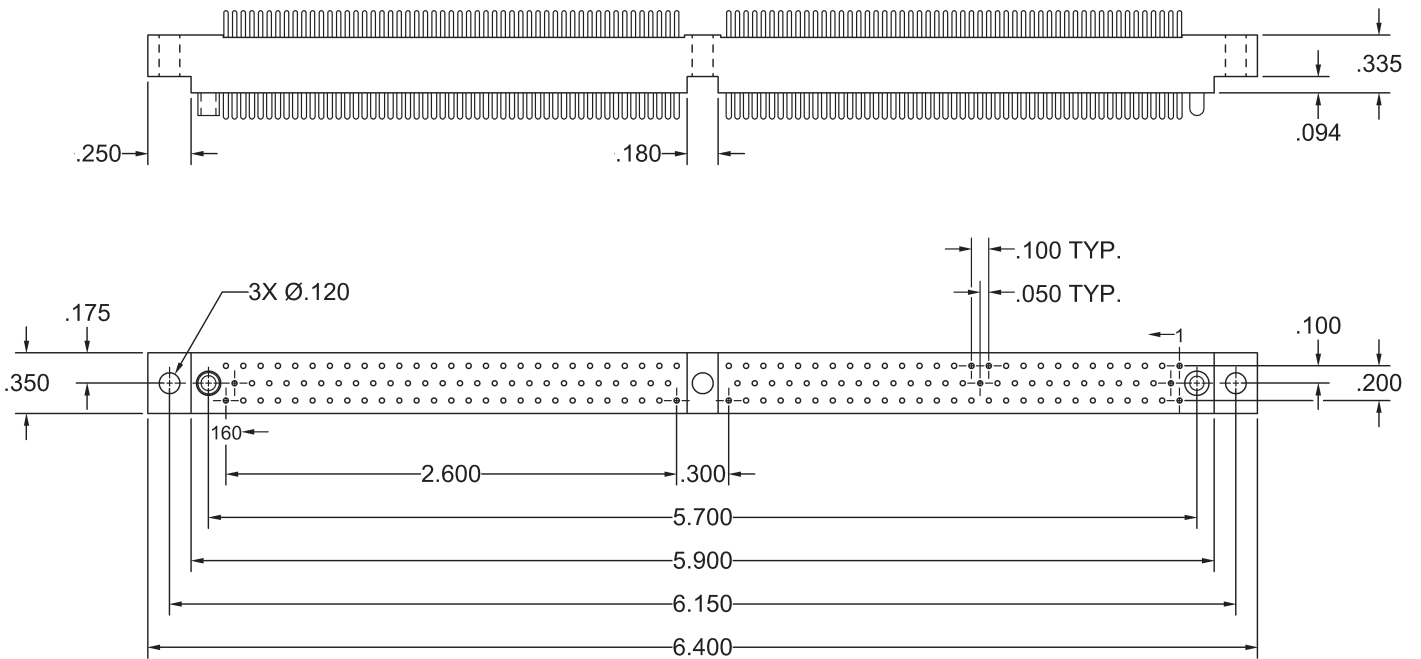

**REFER TO APPENDIX FOR  
TERMINATION DETAILS,  
HARDWARE STYLES,  
POLARIZATION CHART,  
AND PWB PATTERNS**



### PLUG, RIGHT ANGLE STYLE HGM160 MEE, MLE, MXE

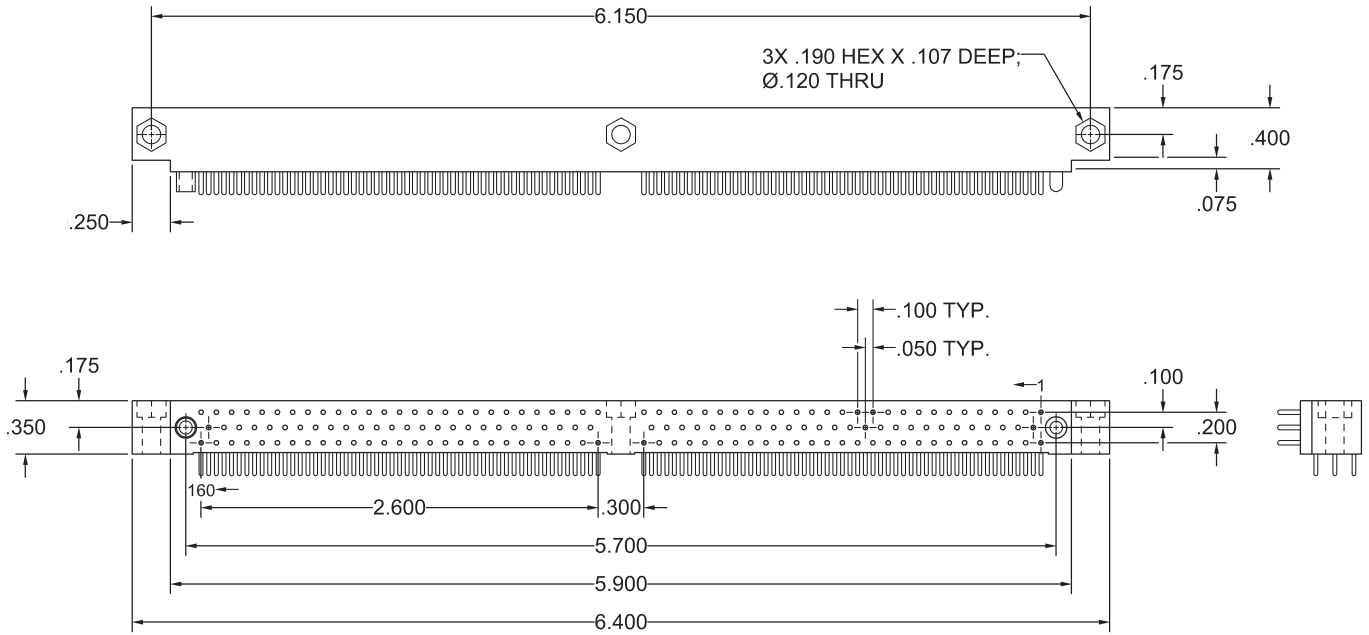

**REFER TO APPENDIX FOR  
TERMINATION DETAILS,  
HARDWARE STYLES,  
POLARIZATION CHART,  
AND PWB PATTERNS**

**PLUG, COMPLIANT  
STYLE HGM160 MVE**

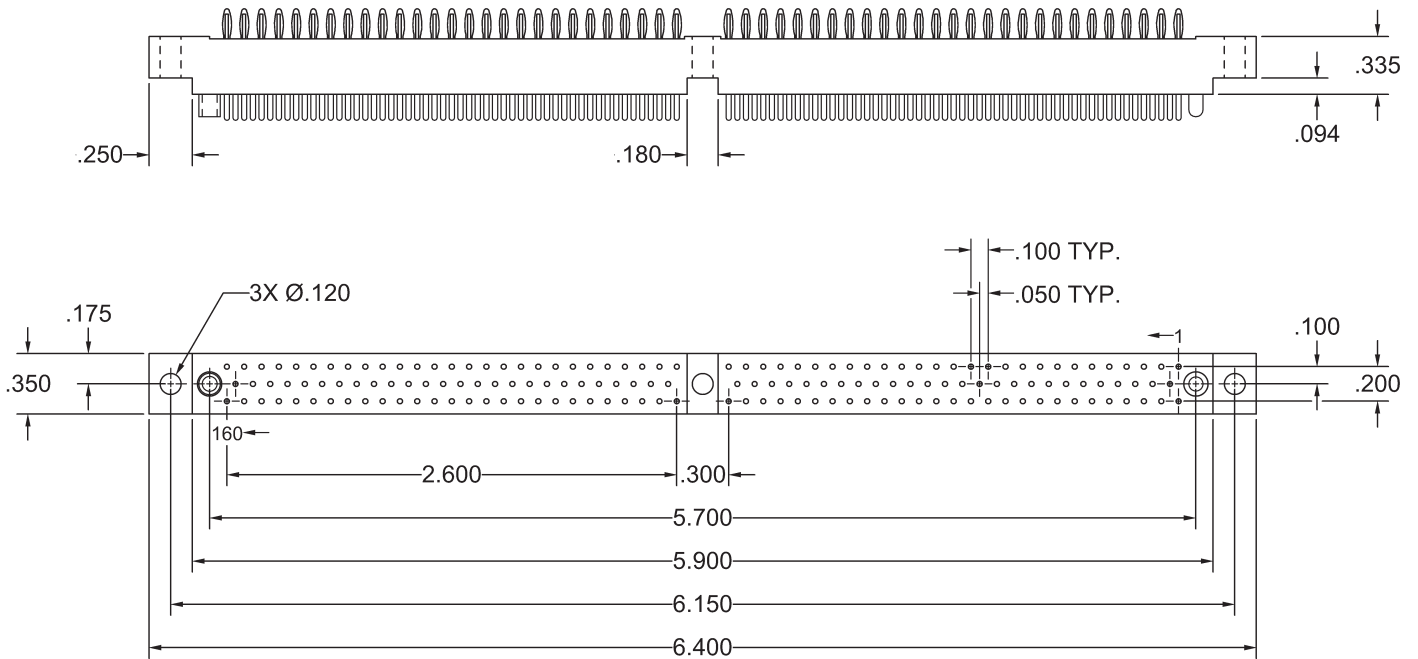

**REFER TO APPENDIX FOR  
TERMINATION DETAILS,  
HARDWARE STYLES,  
POLARIZATION CHART,  
AND PWB PATTERNS**

### RECEPTACLE, STACKING STYLE HGM208 FAE9, FVEA

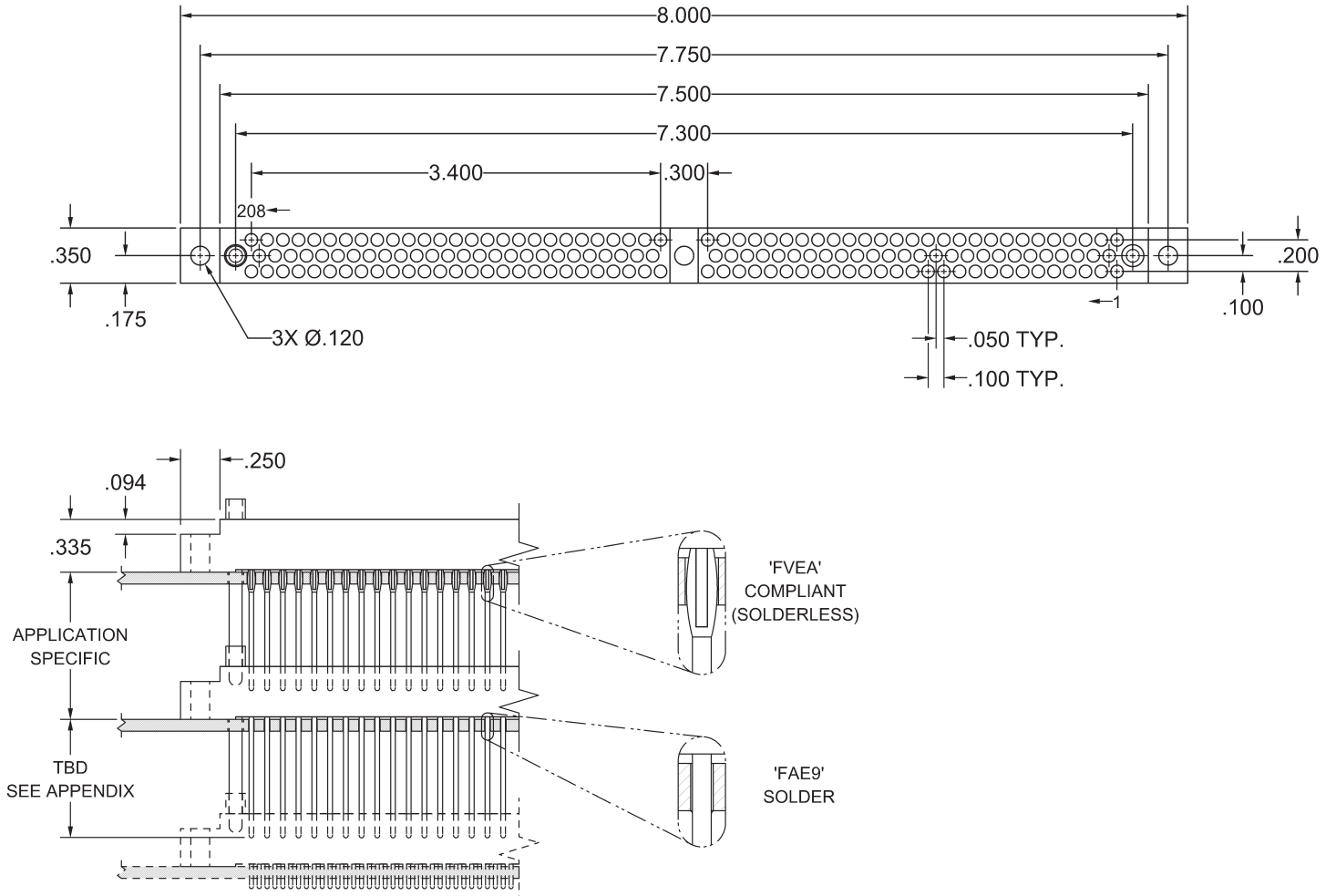

**REFER TO APPENDIX FOR  
TERMINATION DETAILS,  
HARDWARE STYLES,  
POLARIZATION CHART,  
AND PWB PATTERNS**

### RECEPTACLE, STRAIGHT STYLE HGM208 FBE, FDE, FSE, FWE

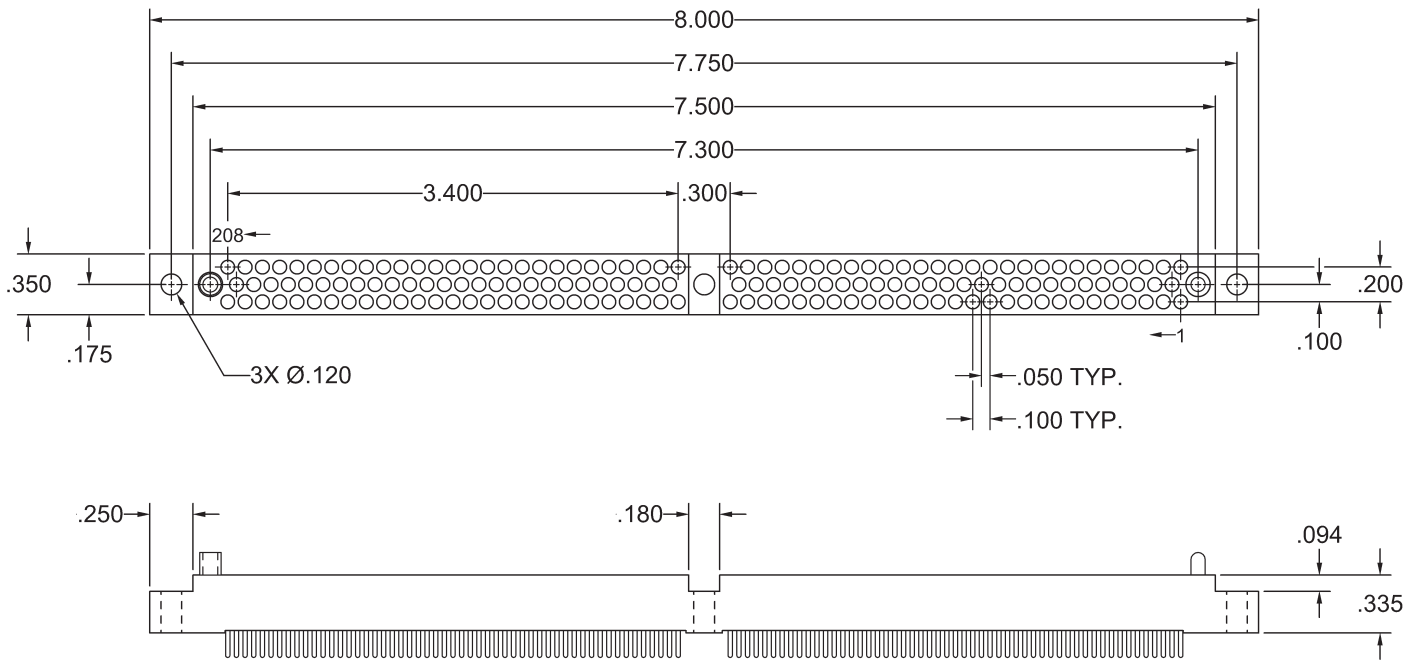

**REFER TO APPENDIX FOR  
TERMINATION DETAILS,  
HARDWARE STYLES,  
POLARIZATION CHART,  
AND PWB PATTERNS**

### RECEPTACLE, RIGHT ANGLE STYLE HGM208 FEE

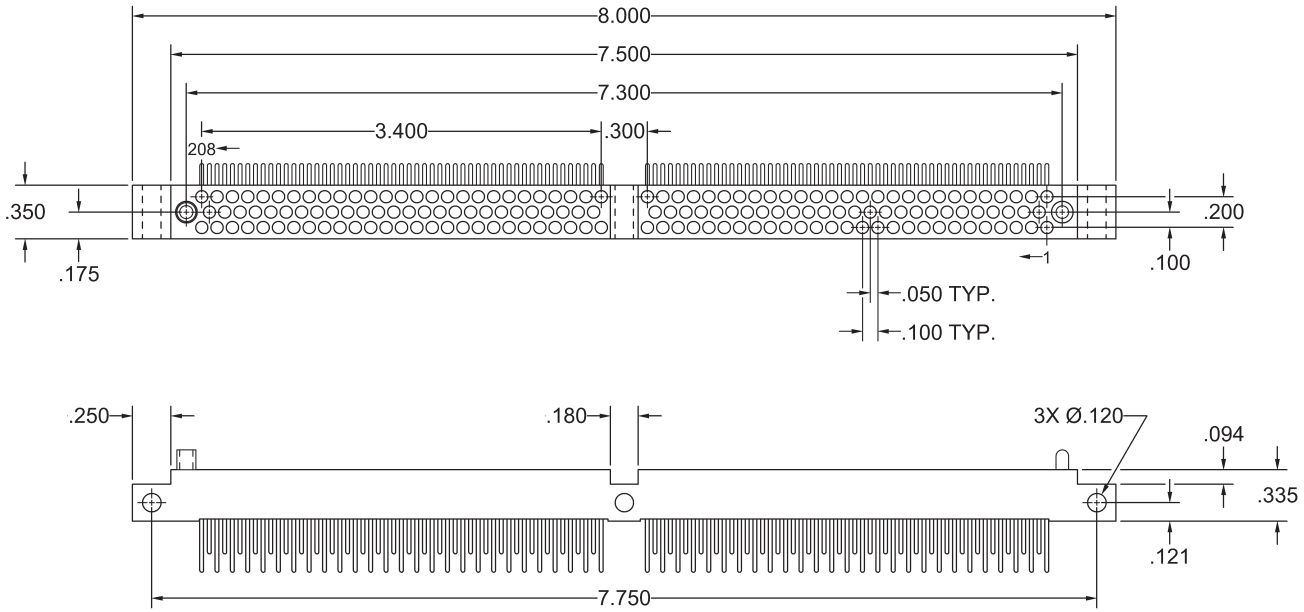

**REFER TO APPENDIX FOR  
TERMINATION DETAILS,  
HARDWARE STYLES,  
POLARIZATION CHART,  
AND PWB PATTERNS**

### RECEPTACLE, COMPLIANT STYLE HGM208 FVE

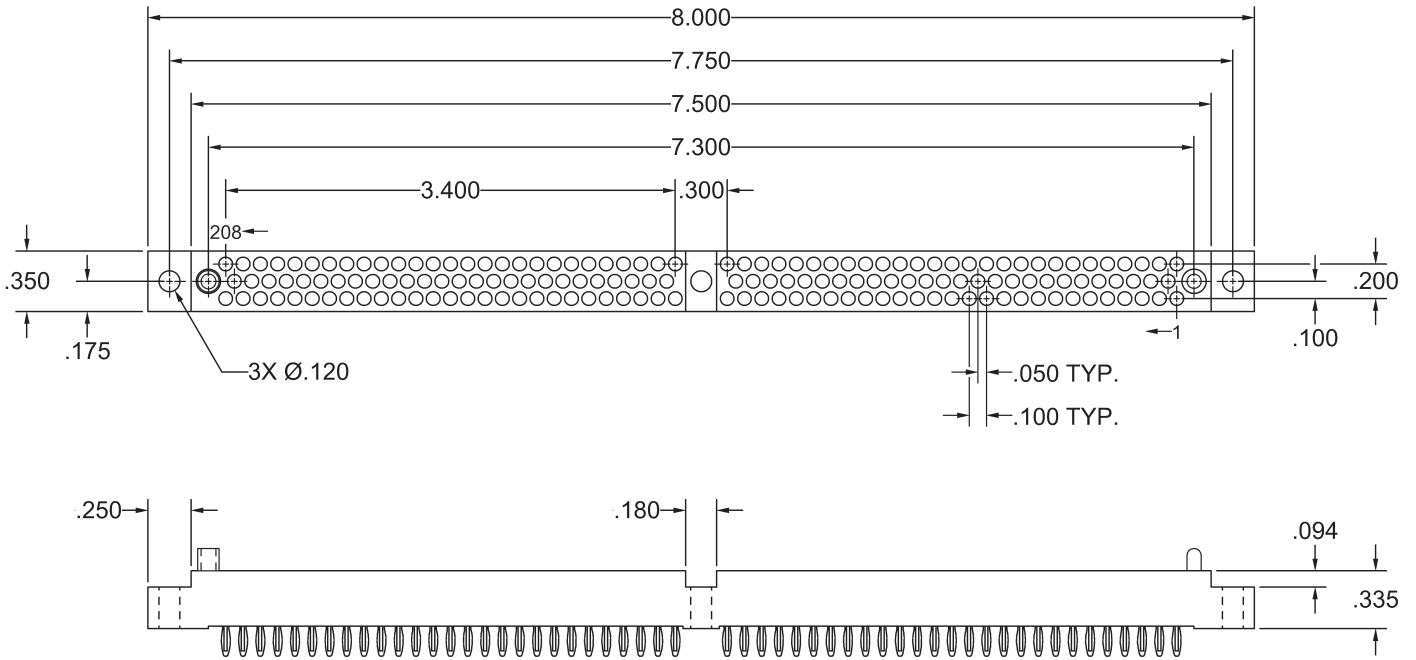

**REFER TO APPENDIX FOR  
TERMINATION DETAILS,  
HARDWARE STYLES,  
POLARIZATION CHART,  
AND PWB PATTERNS**

### PLUG, STACKING STYLE HGM208 MAE9, MVEA

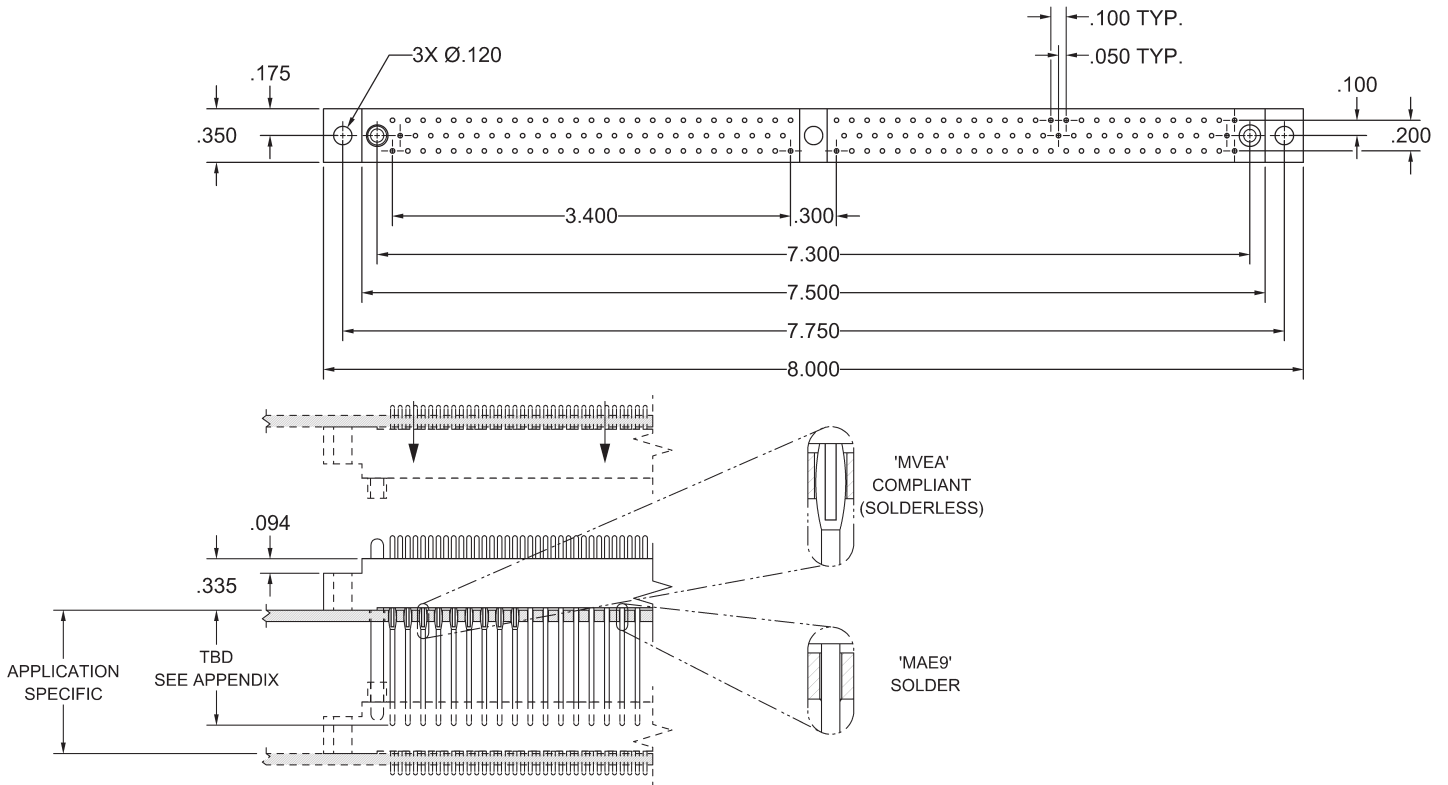

**REFER TO APPENDIX FOR  
TERMINATION DETAILS,  
HARDWARE STYLES,  
POLARIZATION CHART,  
AND PWB PATTERNS**

### PLUG, STRAIGHT STYLE HGM208 MBE, MDE, MSE, MWE

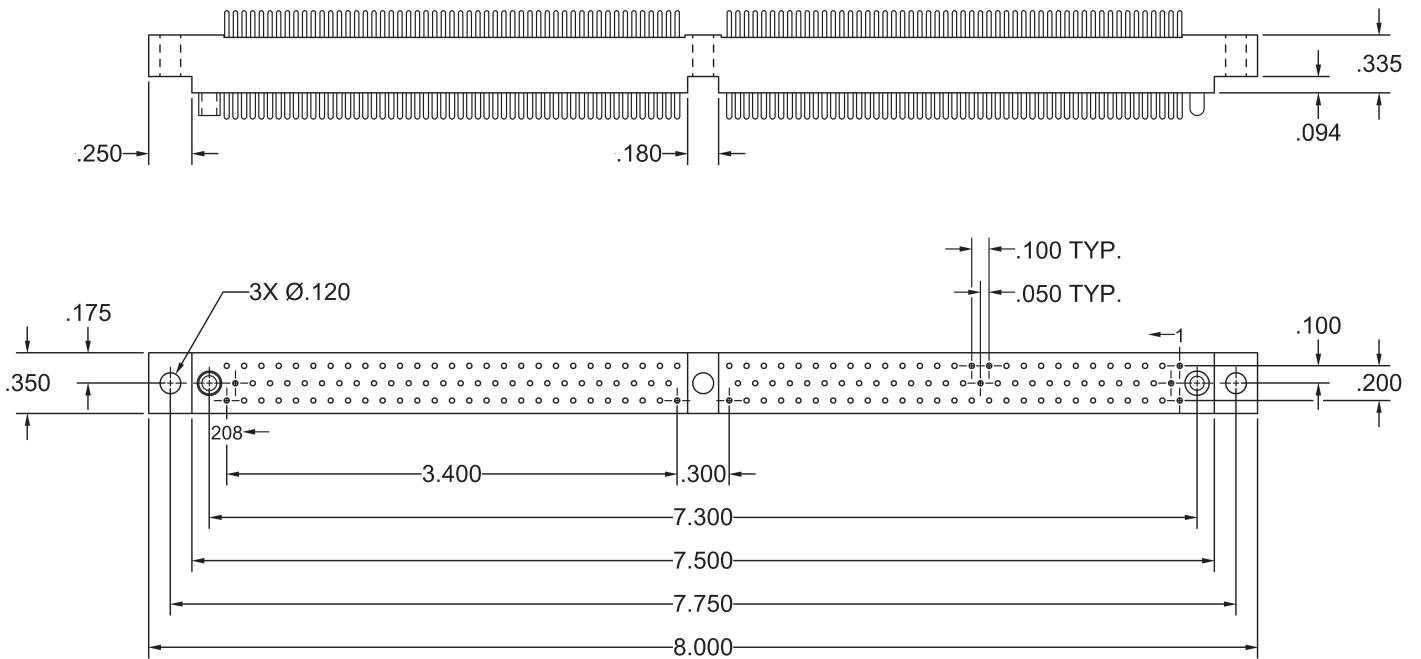

**REFER TO APPENDIX FOR  
TERMINATION DETAILS,  
HARDWARE STYLES,  
POLARIZATION CHART,  
AND PWB PATTERNS**



### PLUG, RIGHT ANGLE STYLE HGM208 MEE, MLE, MXE

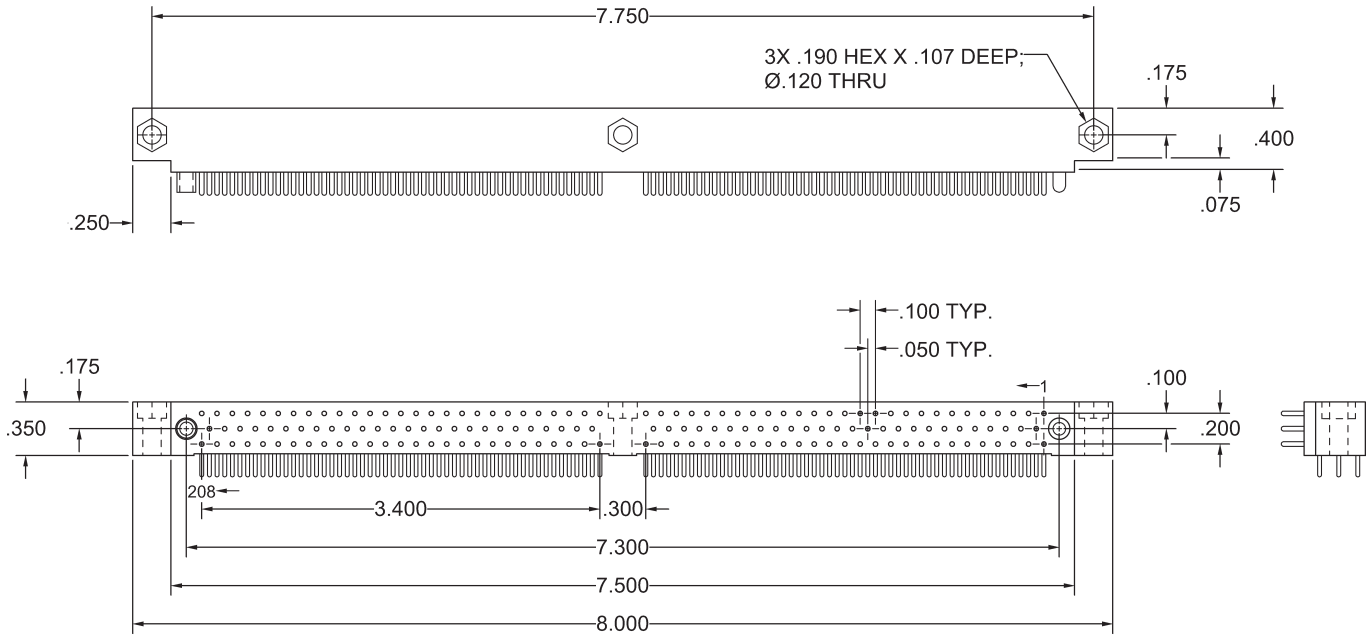

**REFER TO APPENDIX FOR  
TERMINATION DETAILS,  
HARDWARE STYLES,  
POLARIZATION CHART,  
AND PWB PATTERNS**

### PLUG, COMPLIANT STYLE HGM208 MVE

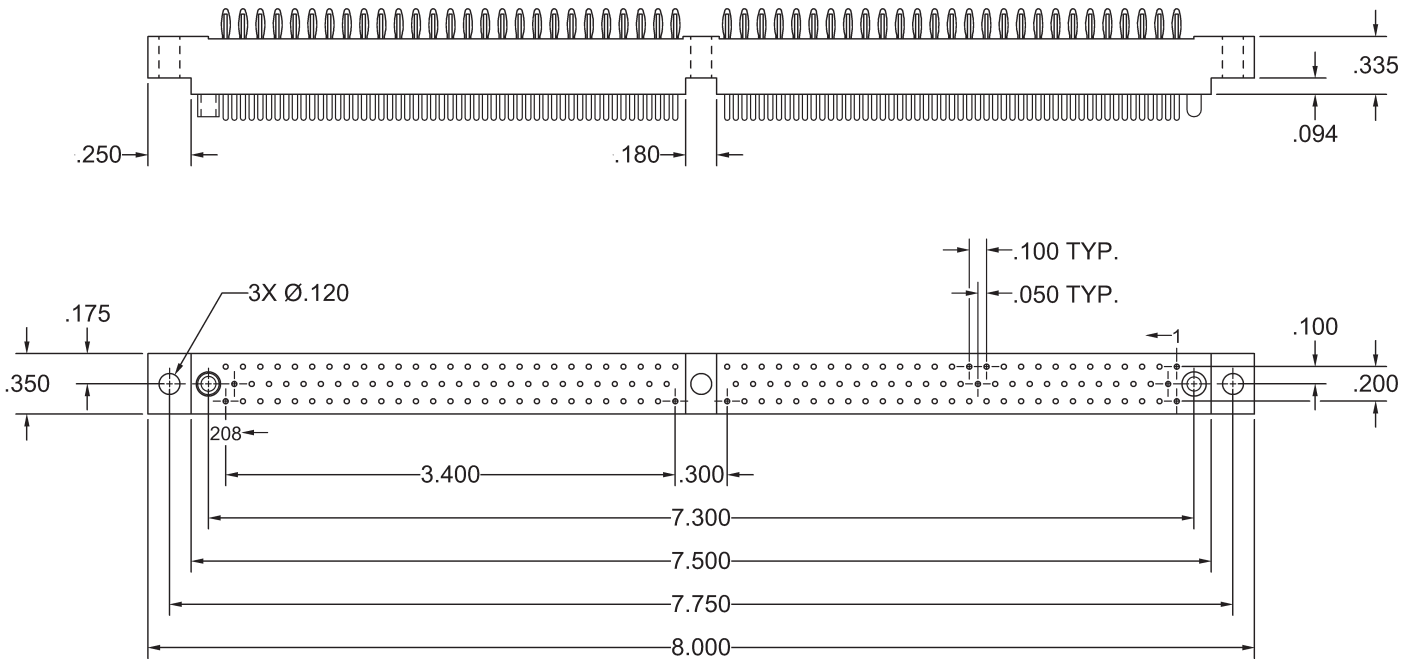

**REFER TO APPENDIX FOR  
TERMINATION DETAILS,  
HARDWARE STYLES,  
POLARIZATION CHART,  
AND PWB PATTERNS**

**RECEPTACLE, STRAIGHT  
STYLE HGM122 FBE, FDE, FSE, FWE**

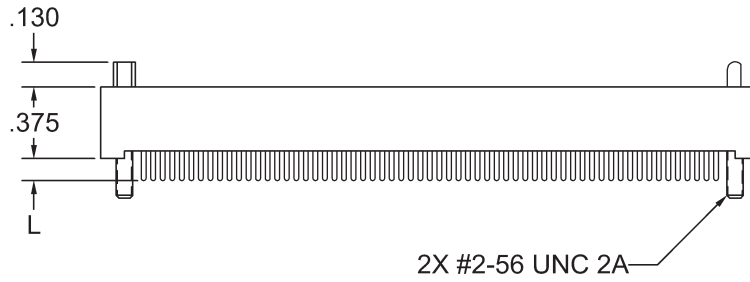
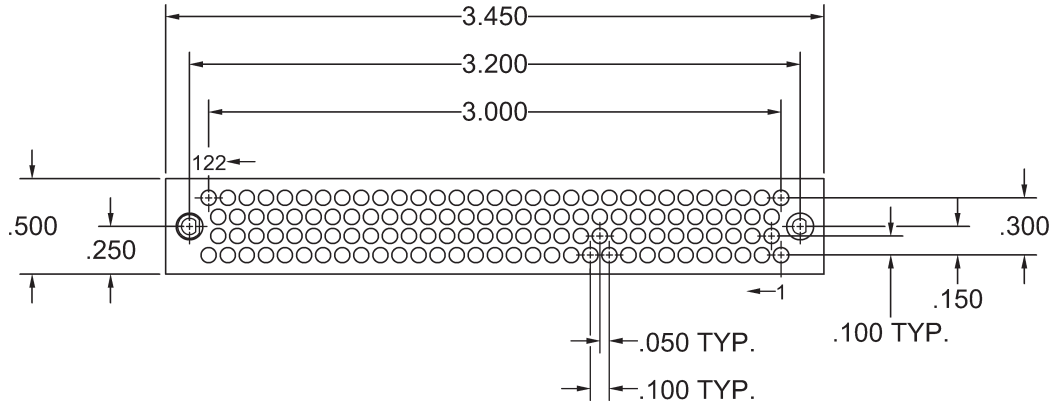

RECEPTACLE, RIGHT ANGLE  
STYLE HGM122 FEE

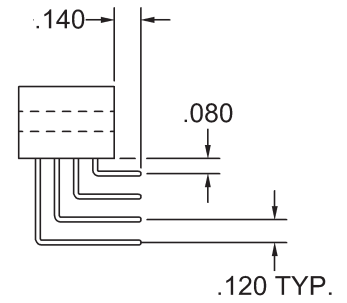
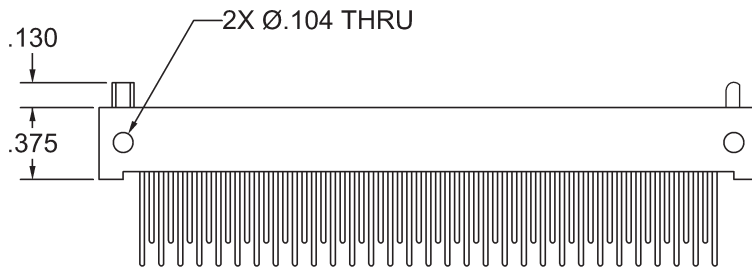
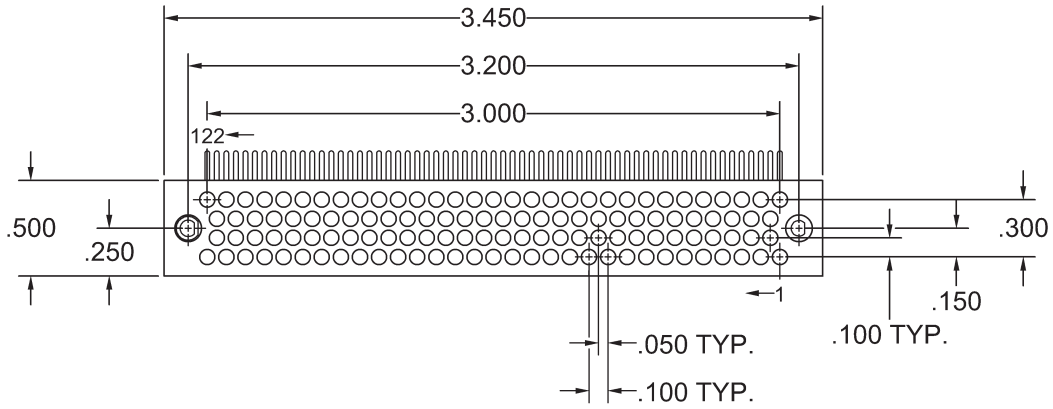

**PLUG, STRAIGHT**  
**STYLE HGM122 MBE, MDE, MSE, MWE**

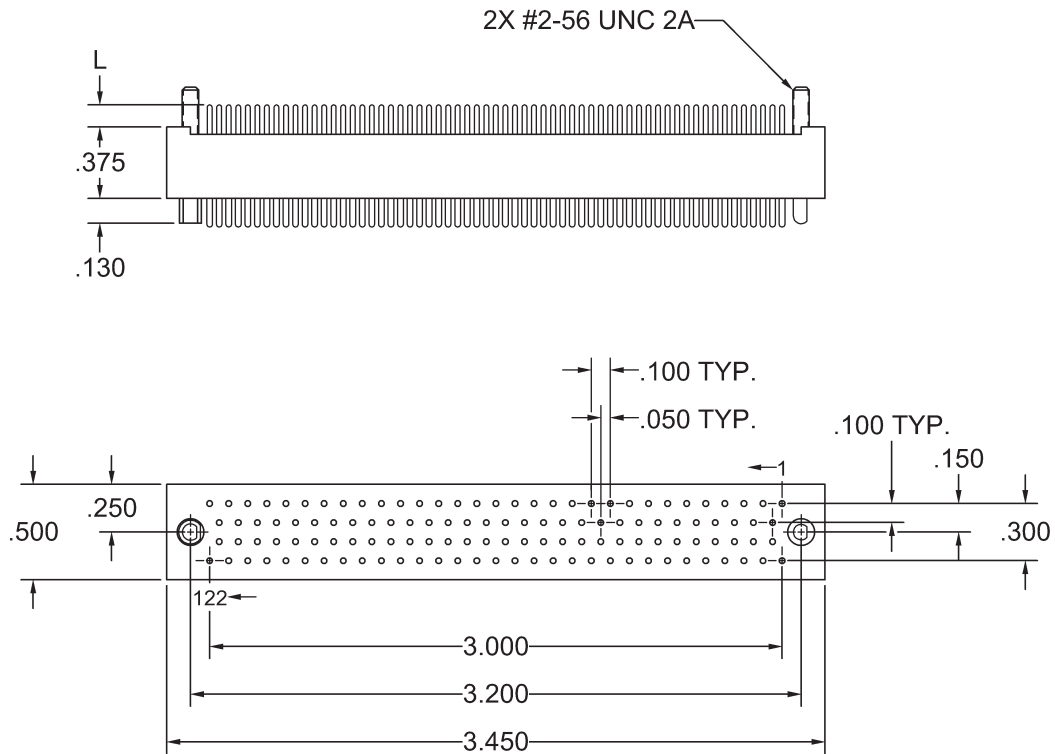

**PLUG, RIGHT ANGLE  
STYLE HGM122 MEE**

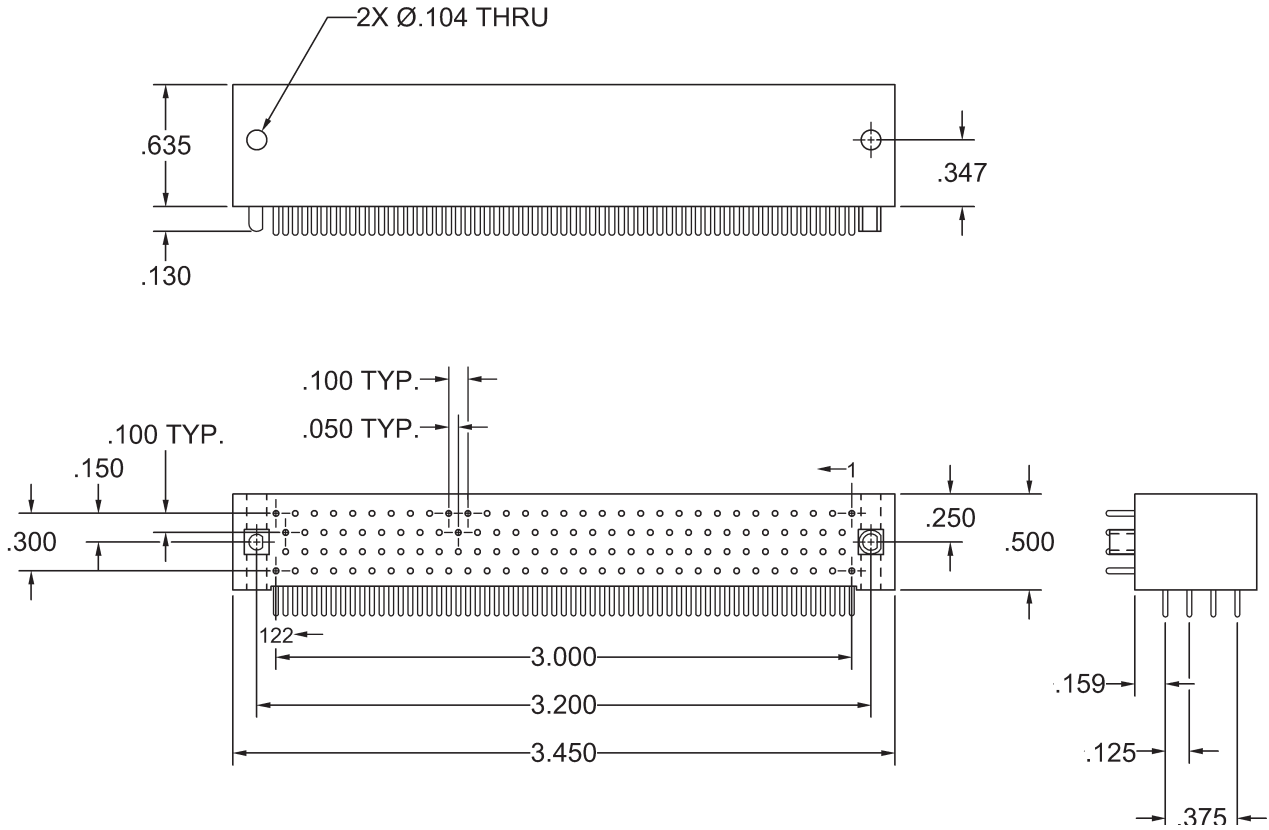

**TERMINATION STYLES - 2ROW  
RECEPTACLE  
HARDWARE OMITTED FOR CLARITY**

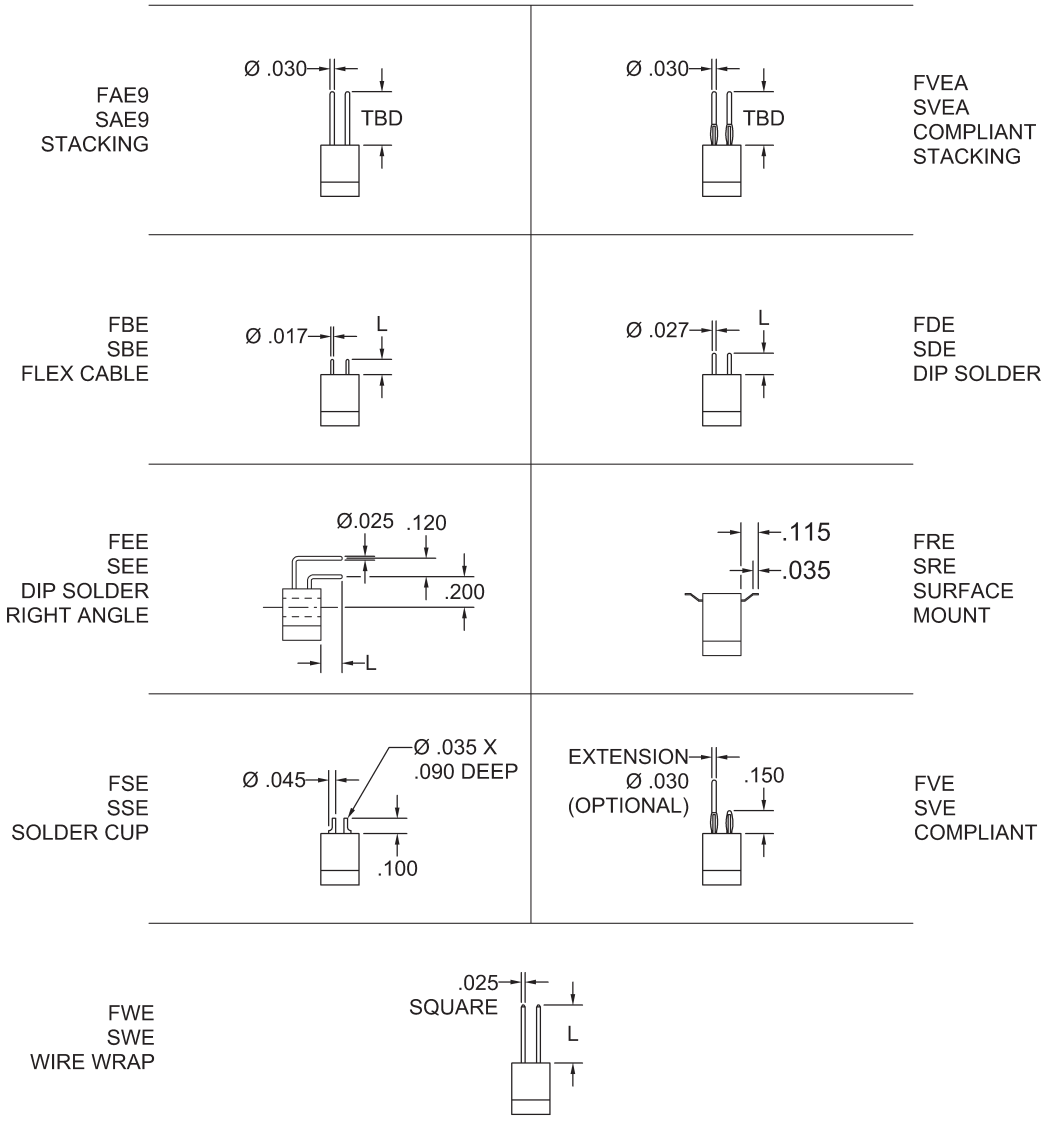

**TERMINATION STYLES - 2 ROW  
PLUG, RIGHT ANGLE  
HARDWARE OMITTED FOR CLARITY**

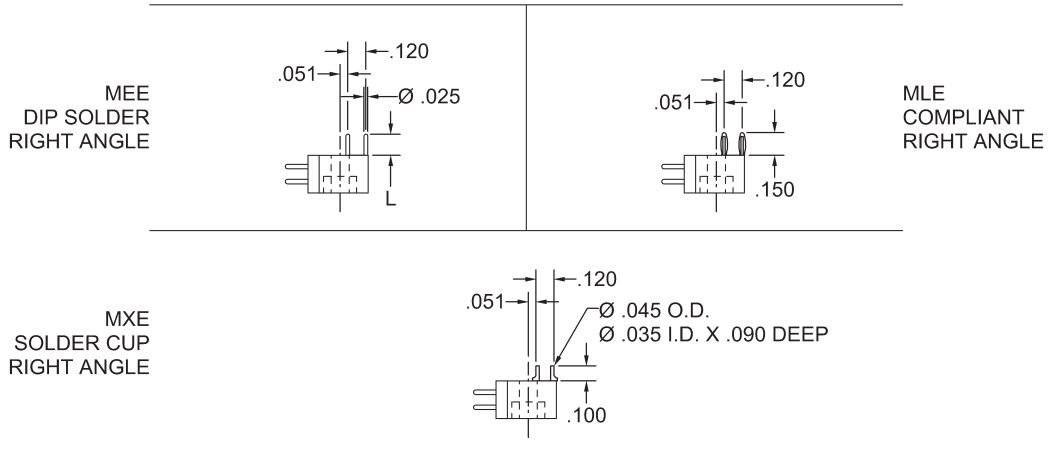



**TERMINATION STYLES - 2 ROW  
PLUG, STRAIGHT  
HARDWARE OMITTED FOR CLARITY**

<p>MAE9 PAE9 STACKING</p>		<p>MVEA PVEA COMPLIANT STACKING</p>
<p>MBE PBE FLEX CABLE</p>		<p>MDE PDE DIP SOLDER</p>
<p>MRE PRE SURFACE MOUNT</p>		<p>MSE PSE SOLDER CUP</p>
<p>MVE PVE COMPLIANT</p>		<p>MWE PWE WIRE WRAP</p>

**TERMINATION STYLES - 2 ROW  
PLUG, STRAIGHT, HIGH PROFILE, 090 & 120 ONLY  
HARDWARE OMITTED FOR CLARITY**

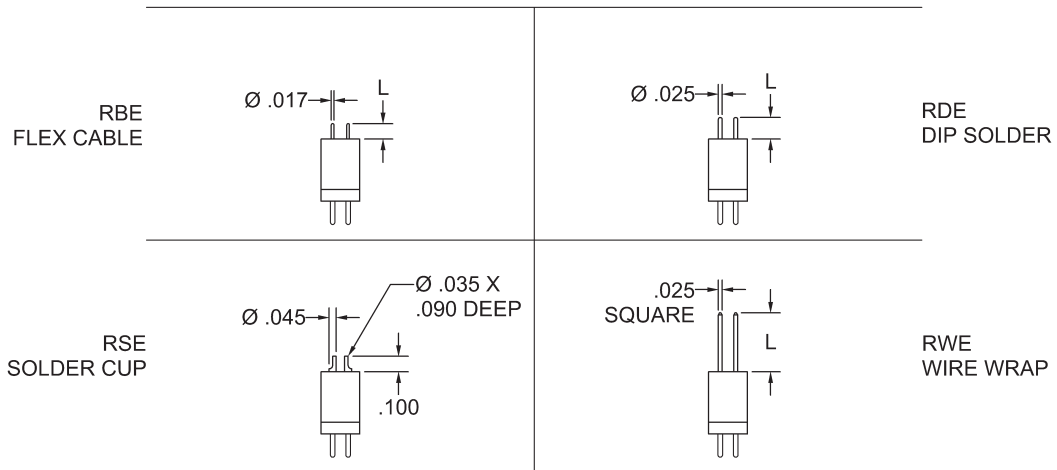

## TERMINATION STYLES - 3 ROW RECEPTACLE HARDWARE OMITTED FOR CLARITY

<p>F AE9 STACKING</p>		<p>FVEA COMPLIANT STACKING</p>																					
<p>FBE FLEX CABLE</p>		<p>FDE DIP SOLDER</p>																					
<p>FVE COMPLIANT</p>	<p>EXTENSION Ø .030 (OPTIONAL)</p>	<p>FWE WIRE WRAP</p>																					
<p>FSE SOLDER CUP</p>		<table border="1" style="width: 100%; border-collapse: collapse;"> <thead> <tr> <th>CONNECTOR</th> <th>A</th> <th>B</th> <th>C</th> </tr> </thead> <tbody> <tr> <td>HGM[050-104]</td> <td>Ø .039 X.090 DEEP</td> <td>0.18</td> <td>0.055</td> </tr> <tr> <td>HGM122</td> <td>Ø .039 X.090 DEEP</td> <td>0.15</td> <td>0.055</td> </tr> <tr> <td>HGM160</td> <td>Ø .035 X.090 DEEP</td> <td>0.10</td> <td>0.045</td> </tr> <tr> <td>HGM208</td> <td>Ø .035 X.090 DEEP</td> <td>0.10</td> <td>0.045</td> </tr> </tbody> </table>		CONNECTOR	A	B	C	HGM[050-104]	Ø .039 X.090 DEEP	0.18	0.055	HGM122	Ø .039 X.090 DEEP	0.15	0.055	HGM160	Ø .035 X.090 DEEP	0.10	0.045	HGM208	Ø .035 X.090 DEEP	0.10	0.045
CONNECTOR	A	B	C																				
HGM[050-104]	Ø .039 X.090 DEEP	0.18	0.055																				
HGM122	Ø .039 X.090 DEEP	0.15	0.055																				
HGM160	Ø .035 X.090 DEEP	0.10	0.045																				
HGM208	Ø .035 X.090 DEEP	0.10	0.045																				
<p>FEE DIP SOLDER RIGHT ANGLE</p>		<table border="1" style="width: 100%; border-collapse: collapse;"> <thead> <tr> <th>CONNECTOR</th> <th>A</th> <th>B</th> </tr> </thead> <tbody> <tr> <td>HGM[050-104]</td> <td>0.200</td> <td>0.120</td> </tr> <tr> <td>HGM122</td> <td>0.240</td> <td>0.125</td> </tr> <tr> <td>HGM160</td> <td>0.200</td> <td>0.120</td> </tr> <tr> <td>HGM208</td> <td>0.200</td> <td>0.120</td> </tr> </tbody> </table>		CONNECTOR	A	B	HGM[050-104]	0.200	0.120	HGM122	0.240	0.125	HGM160	0.200	0.120	HGM208	0.200	0.120					
CONNECTOR	A	B																					
HGM[050-104]	0.200	0.120																					
HGM122	0.240	0.125																					
HGM160	0.200	0.120																					
HGM208	0.200	0.120																					

**TERMINATION STYLES - 3 ROW  
PLUG, RIGHT ANGLE  
HARDWARE OMITTED FOR CLARITY**

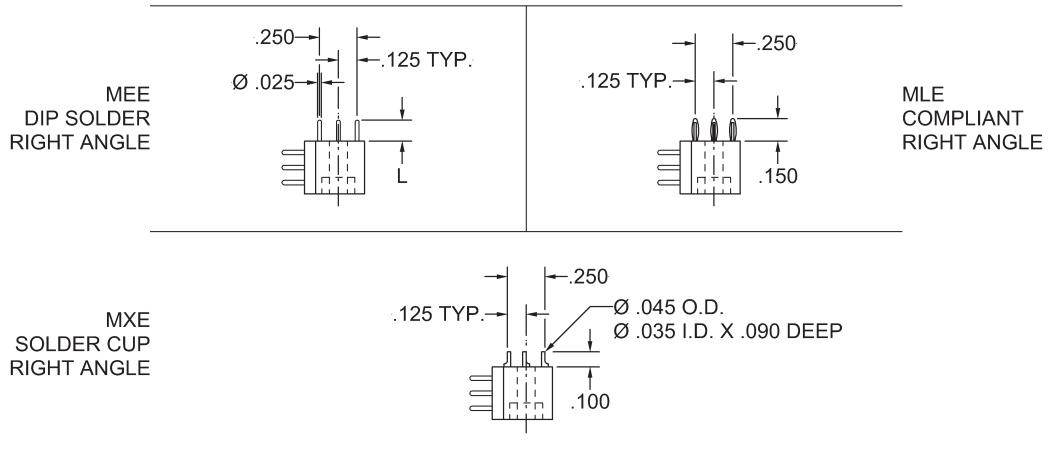

**TERMINATION STYLES - 3 ROW  
PLUG, STRAIGHT  
HARDWARE OMITTED FOR CLARITY**

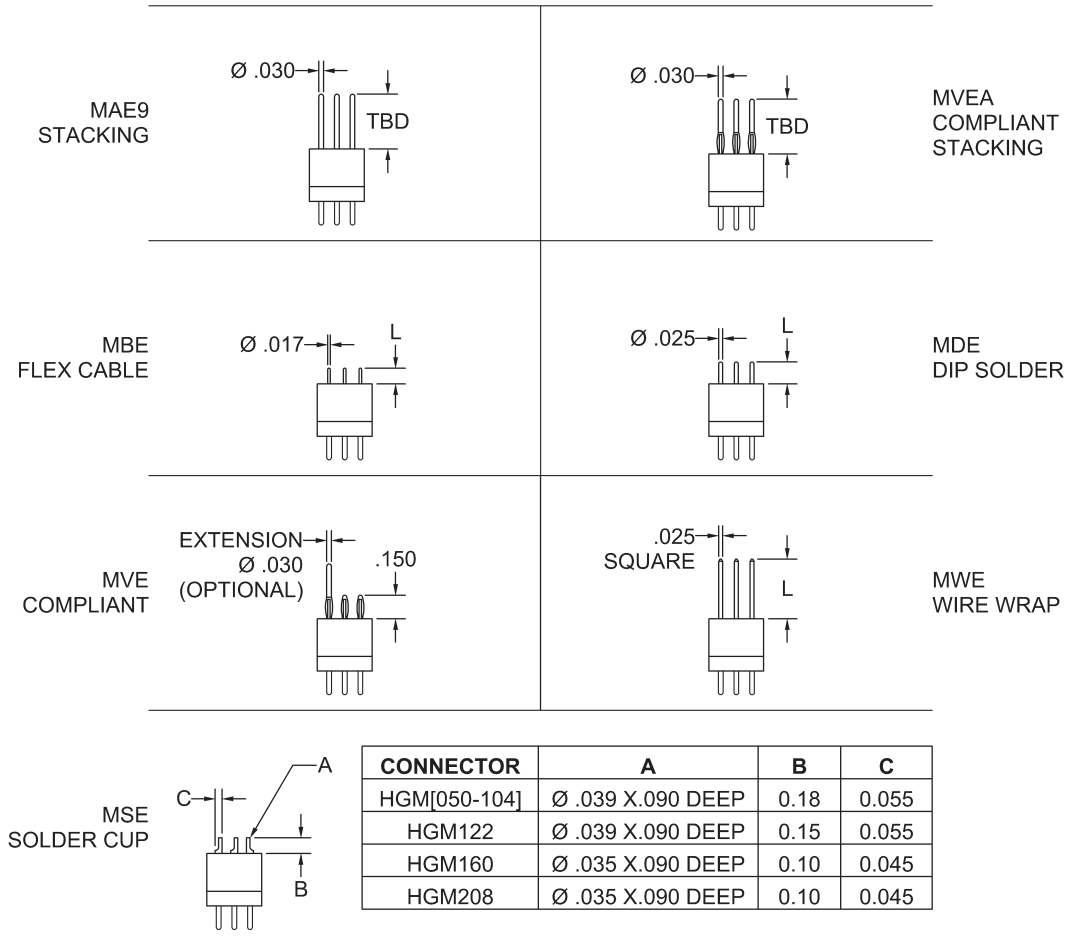

### HARDWARE STYLES 2 & 3 ROW

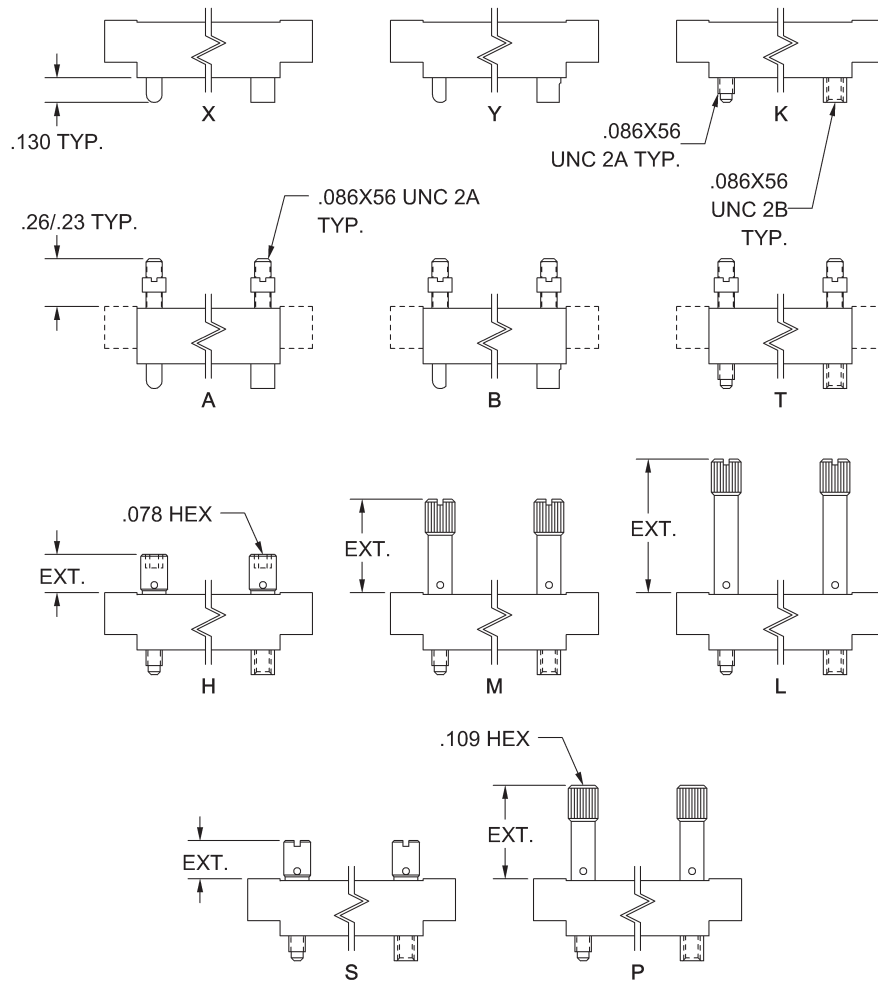

HARDWARE EXTENSION (EXT.)		
STYLE	LOW PROFILE INSULATOR	HIGH PROFILE INSULATOR
H,S	.200	.135
M,P	.500	.435
L	.700	.635

HARDWARE COMPATIBILITY											
	A	B	H	K	L	M	P	S	T	X	Y
A	•									•	
B		•									•
H				•					•		
K			•		•	•	•	•			
L				•					•		
M				•					•		
P				•					•		
S				•					•		
T			•		•	•	•	•			
X	•									•	
Y		•									•

## POLARIZATION CHART 2 & 3 ROW

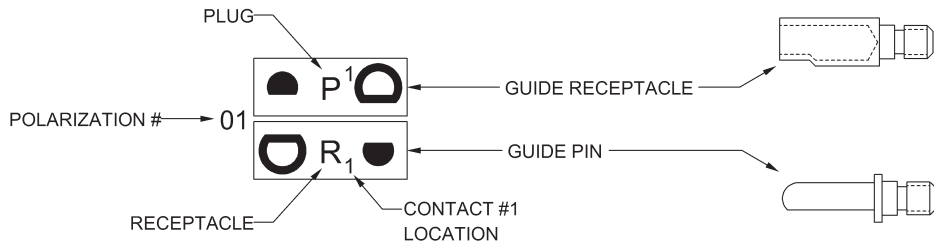

01 - 64 USE FOR HARDWARE STYLE 'Y' AND 'B'

01	09	17	25	33	41	49	57
02	10	18	26	34	42	50	58
03	11	19	27	35	43	51	59
04	12	20	28	36	44	52	60
05	13	21	29	37	45	53	61
06	14	22	30	38	46	54	62
07	15	23	31	39	47	55	63
08	16	24	32	40	48	56	64

UNIVERSAL TEST

USE FOR OPTION: A,H,K,L,M,P,S,T,X

65	66	67	68	69	70	71	72
----	----	----	----	----	----	----	----

**PWB PATTERN - 2 ROW**  
**010-070, RECEPTACLE PATTERN**  
**AS VIEWED FROM THE COMPONENT SIDE**

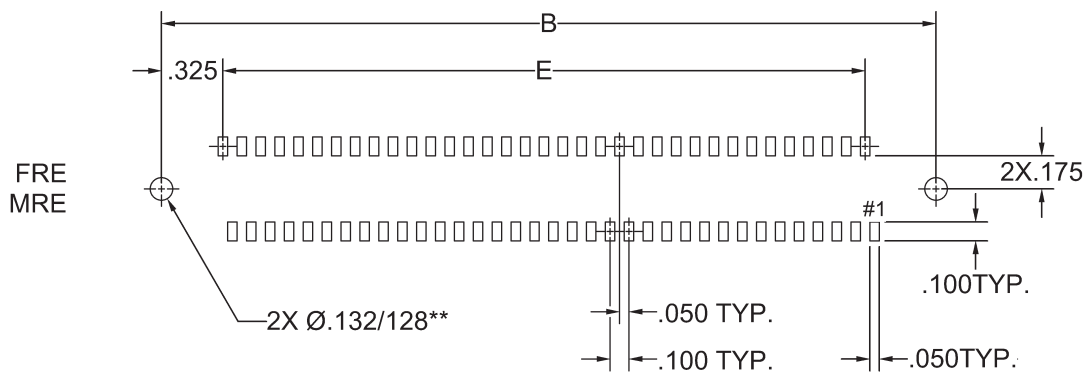
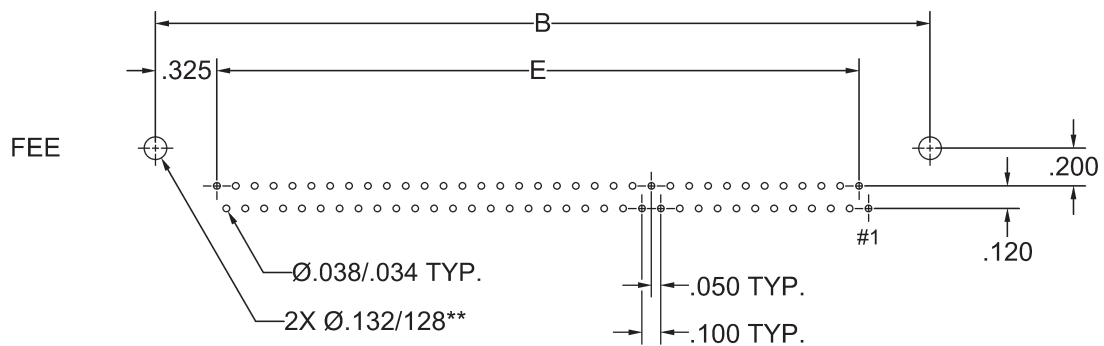
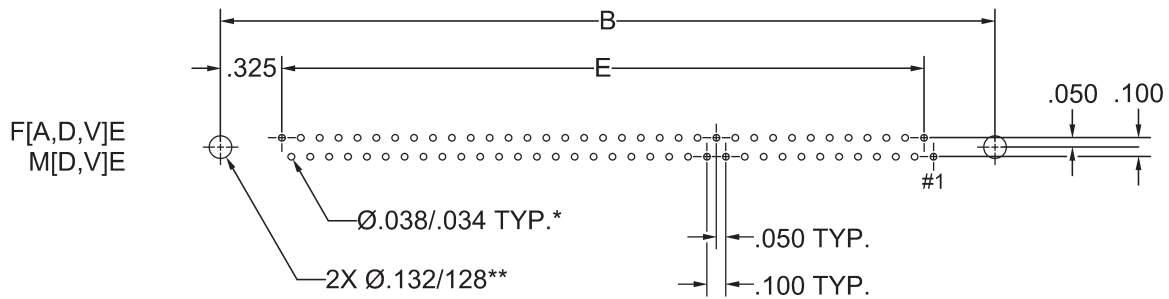

\*.042/.038 RECOMMENDED HOLE SIZE FOR COMPLIANT TERMINATION STYLE CONTACTS.. FOR ALL OTHERS, HOLE SIZE SUBJECT TO USER MODIFICATION FOR APPLICATION OR ALTERNATIVE STANDARDS.

\*\*RECOMMENDATION. MAY BE MODIFIED FOR APPLICATION OR ALTERNATIVE STANDARDS.



**PWB PATTERN - 2 ROW  
010-070, PLUG PATTERN  
AS VIEWED FROM THE COMPONENTSIDE**

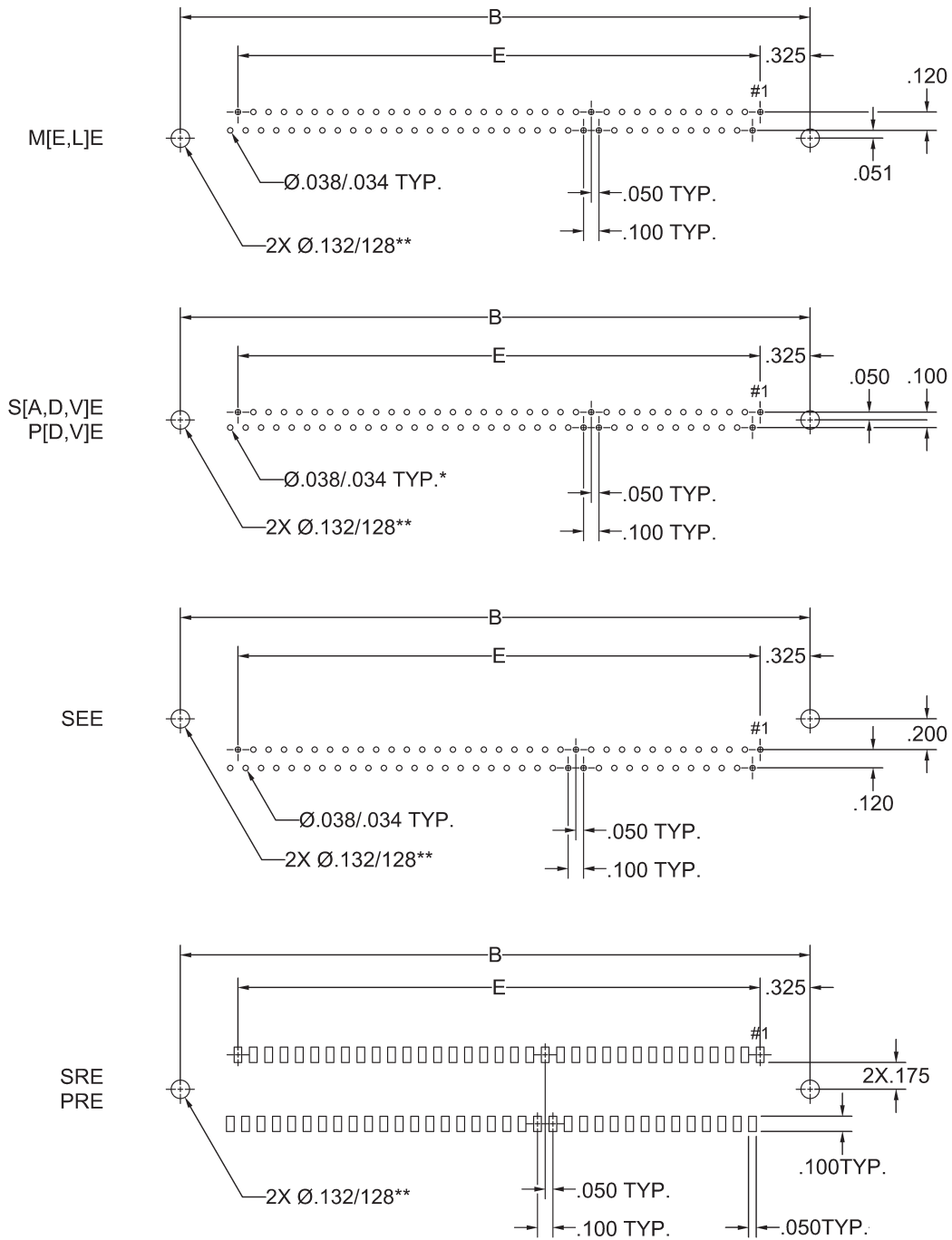

\*.042/.038 RECOMMENDED HOLE SIZE FOR COMPLIANT TERMINATION STYLE CONTACTS. FOR ALL OTHERS, HOLE SIZE SUBJECT TO USER MODIFICATION FOR APPLICATION OR ALTERNATIVE STANDARDS.

\*\*RECOMMENDATION. MAY BE MODIFIED FOR APPLICATION OR ALTERNATIVE STANDARDS.

**PWB PATTERN - 2 ROW  
090, RECEPTACLE PATTERN  
AS VIEWED FROM THE COMPONENT SIDE**

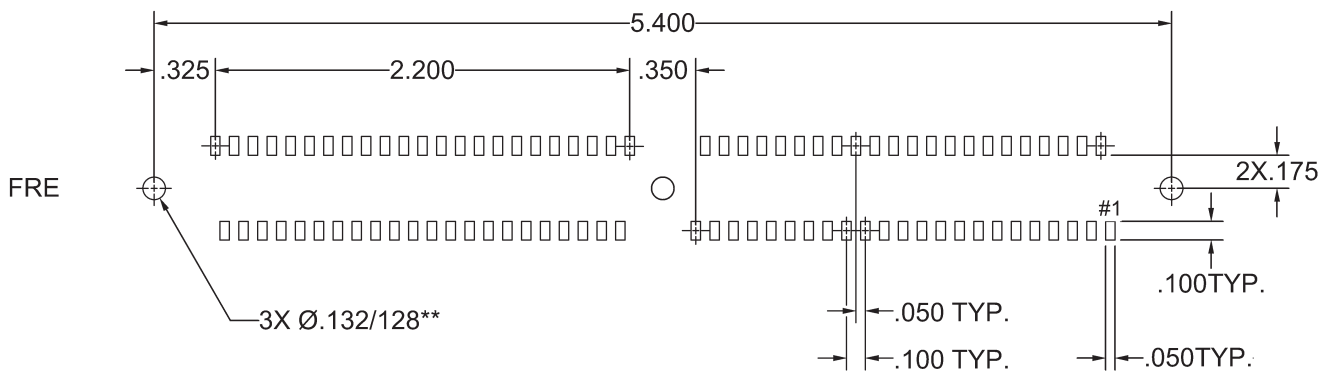
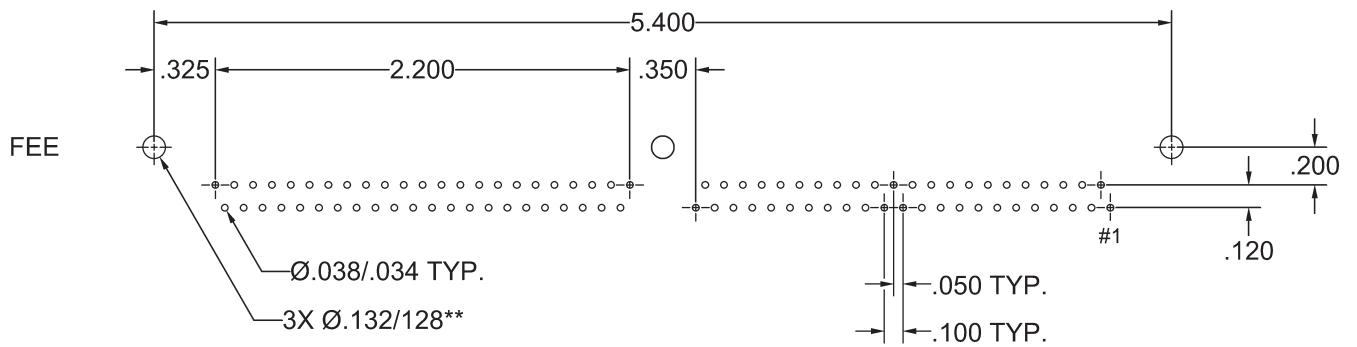
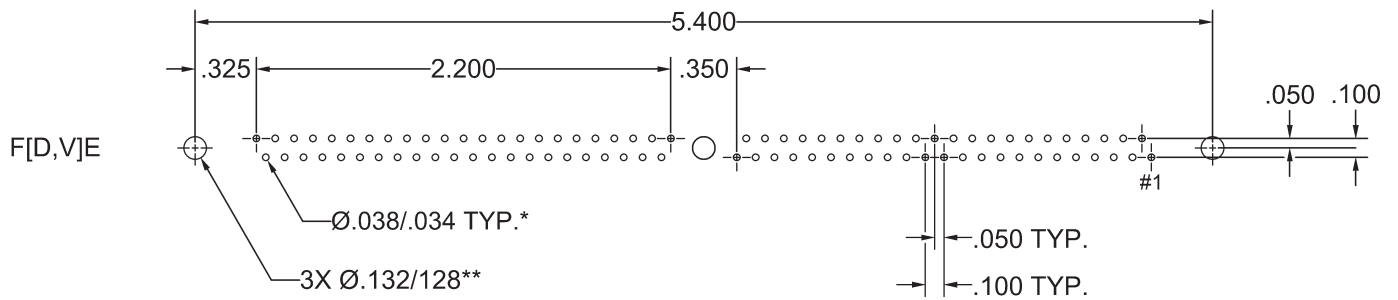

\*.042/.038 RECOMMENDED HOLE SIZE FOR COMPLIANT TERMINATION STYLE CONTACTS.. FOR ALL OTHERS, HOLE SIZE SUBJECT TO USER MODIFICATION FOR APPLICATION OR ALTERNATIVE STANDARDS.

\*\*RECOMMENDATION. MAY BE MODIFIED FOR APPLICATION OR ALTERNATIVE STANDARDS.

**PWB PATTERN - 2 ROW  
090, PLUG PATTERN  
AS VIEWED FROM THE COMPONENT SIDE**

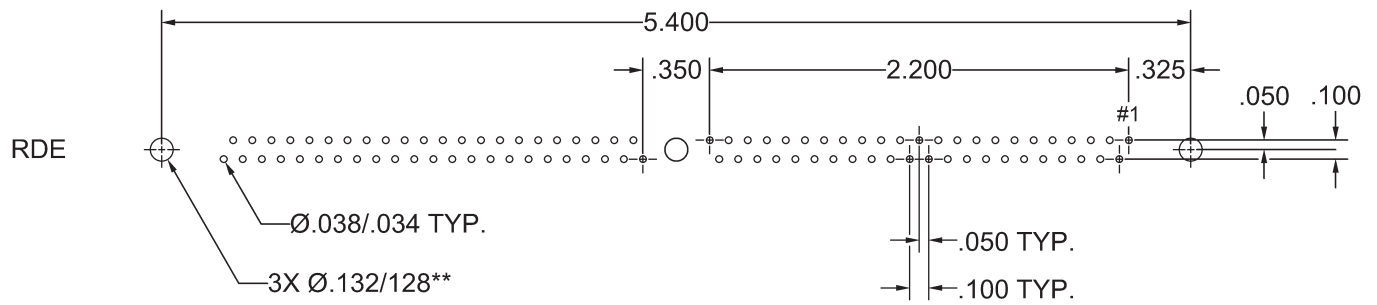
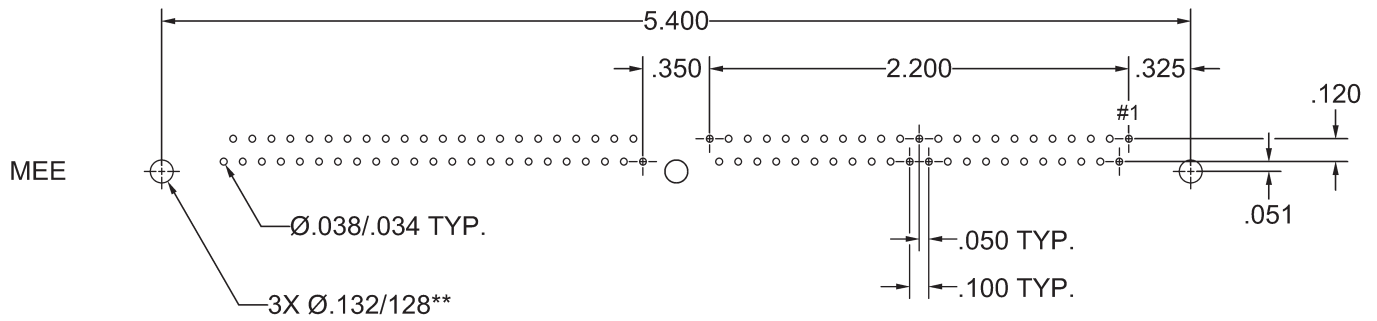

\*\*RECOMMENDATION. MAY BE MODIFIED FOR APPLICATION OR ALTERNATIVE STANDARDS.

**PWB PATTERN - 2 ROW  
100, RECEPTACLE PATTERN  
AS VIEWED FROM THE COMPONENT SIDE**

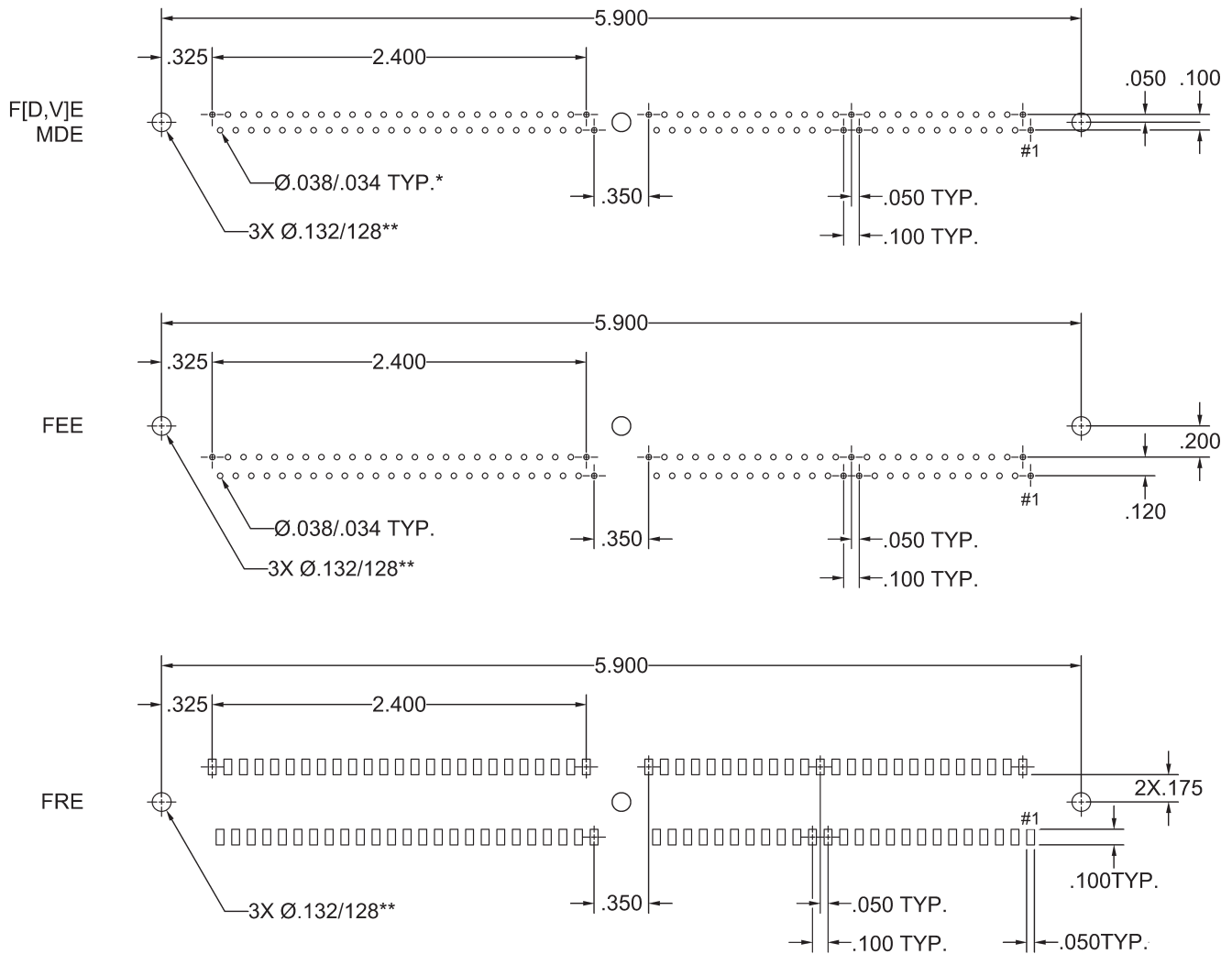

\*.042/.038 RECOMMENDED HOLE SIZE FOR COMPLIANT TERMINATION STYLE CONTACTS.. FOR ALL OTHERS, HOLE SIZE SUBJECT TO USER MODIFICATION FOR APPLICATION OR ALTERNATIVE STANDARDS.

\*\*RECOMMENDATION. MAY BE MODIFIED FOR APPLICATION OR ALTERNATIVE STANDARDS.

**PWB PATTERN - 2 ROW  
100, PLUG PATTERN  
AS VIEWED FROM THE COMPONENT SIDE**

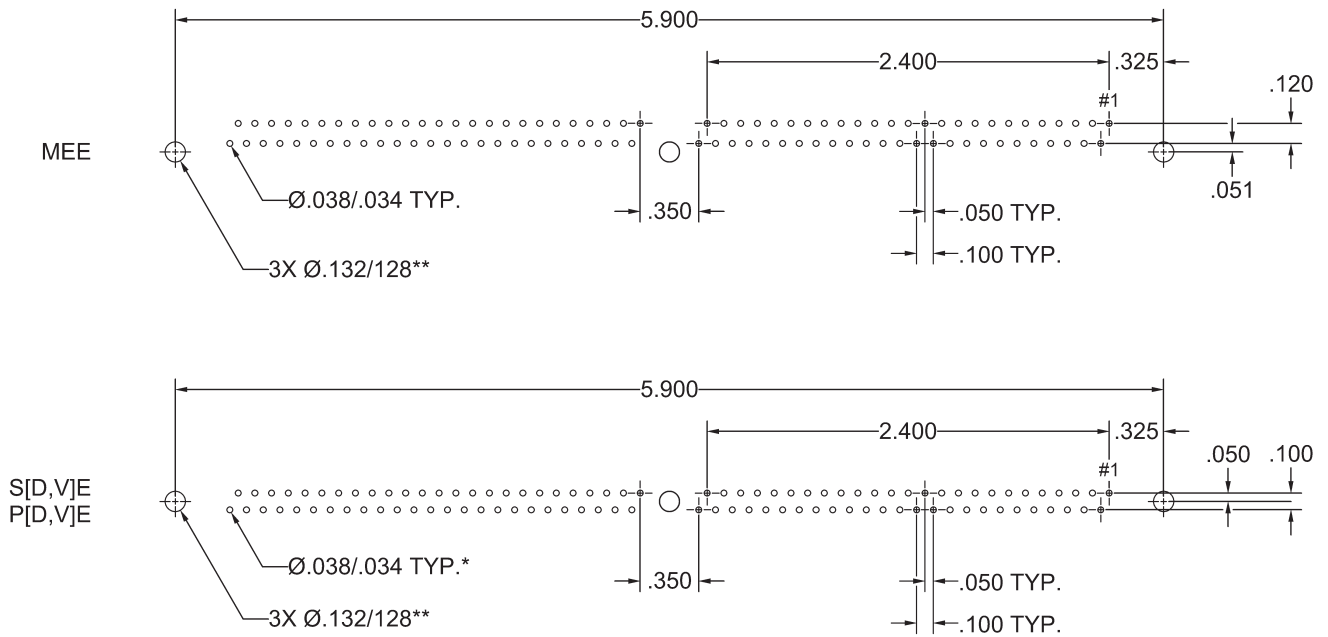

\*.042/.038 RECOMMENDED HOLE SIZE FOR COMPLIANT TERMINATION STYLE CONTACTS. FOR ALL OTHERS, HOLE SIZE SUBJECT TO USER MODIFICATION FOR APPLICATION OR ALTERNATIVE STANDARDS.

\*\*RECOMMENDATION. MAY BE MODIFIED FOR APPLICATION OR ALTERNATIVE STANDARDS.

**PWB PATTERN - 2 ROW  
120, RECEPTACLE PATTERN  
AS VIEWED FROM THE COMPONENT SIDE**

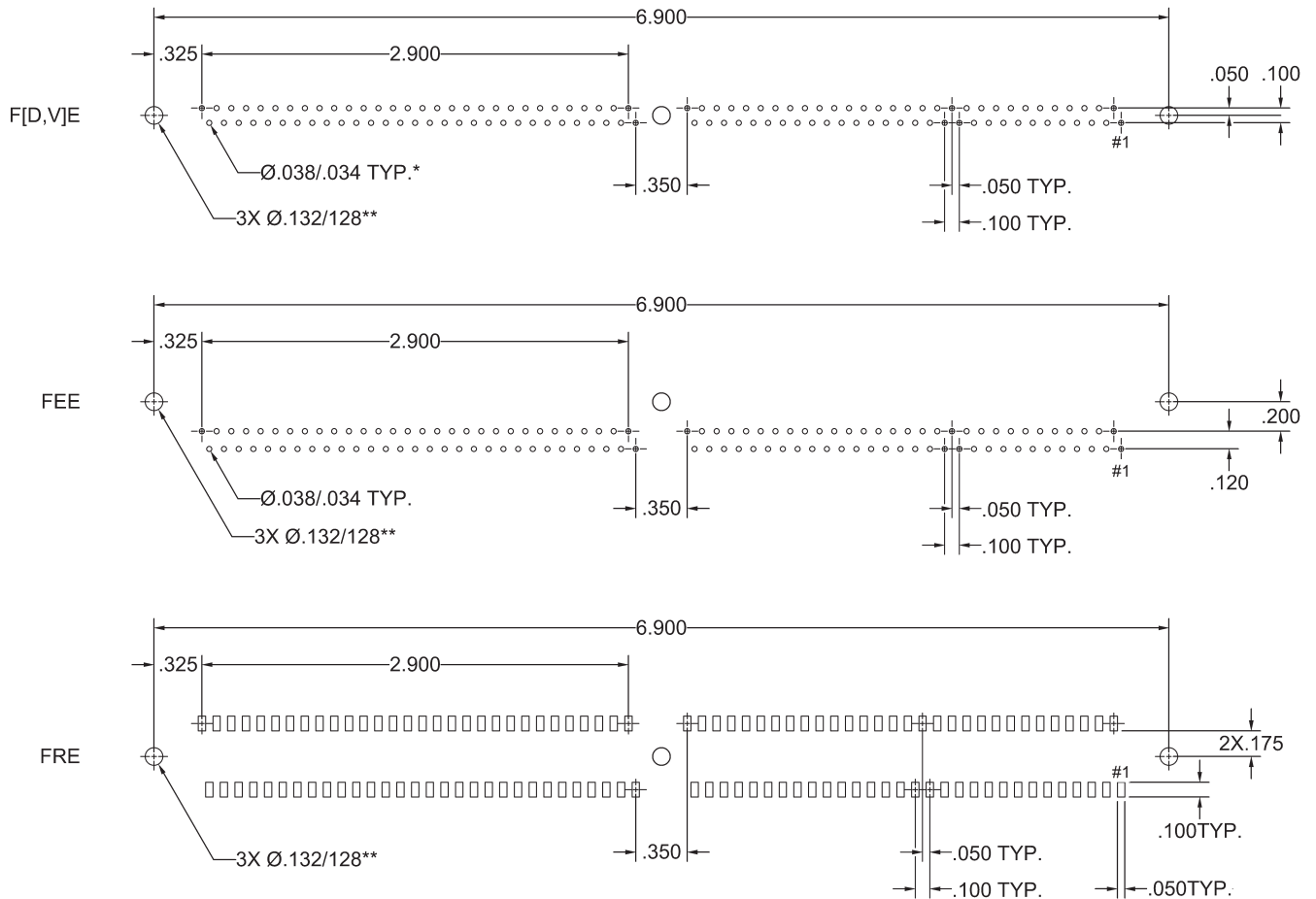

\*.042/.038 RECOMMENDED HOLE SIZE FOR COMPLIANT TERMINATION STYLE CONTACTS.. FOR ALL OTHERS, HOLE SIZE SUBJECT TO USER MODIFICATION FOR APPLICATION OR ALTERNATIVE STANDARDS.

\*\*RECOMMENDATION. MAY BE MODIFIED FOR APPLICATION OR ALTERNATIVE STANDARDS.



**PWB PATTERN - 3 ROW**  
**050-104**  
**AS VIEWED FROM THE COMPONENT SIDE**

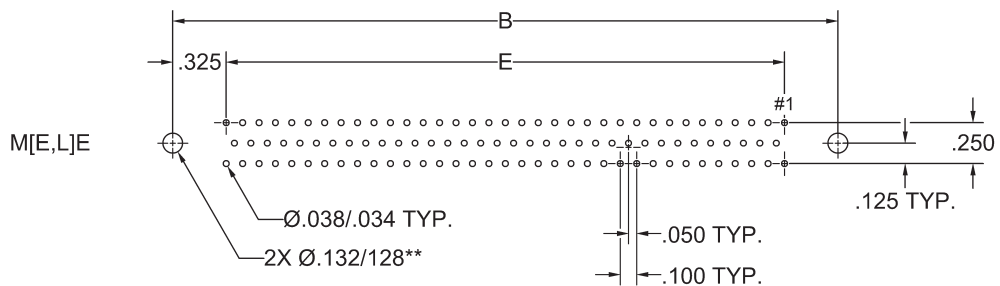
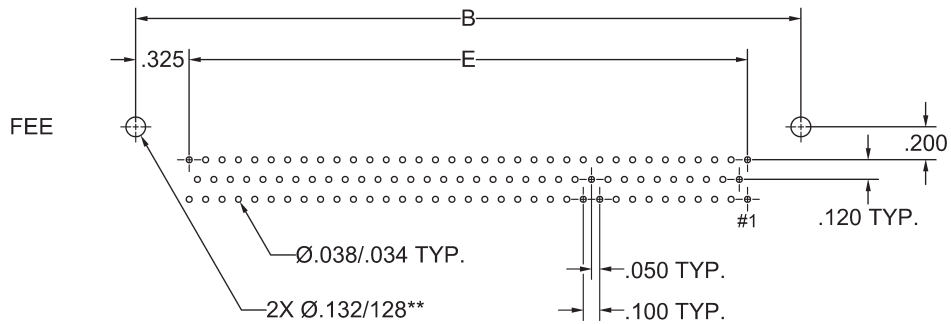
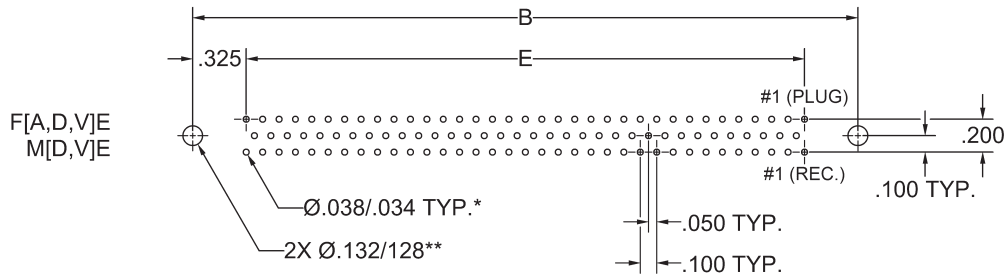

\*.042/.038 RECOMMENDED HOLE SIZE FOR COMPLIANT TERMINATION STYLE CONTACTS.. FOR ALL OTHERS, HOLE SIZE SUBJECT TO USER MODIFICATION FOR APPLICATION OR ALTERNATIVE STANDARDS.

\*\*RECOMMENDATION. MAY BE MODIFIED FOR APPLICATION OR ALTERNATIVE STANDARDS.



**PWB PATTERN - 3 ROW**  
**122**  
**AS VIEWED FROM THE COMPONENT SIDE**

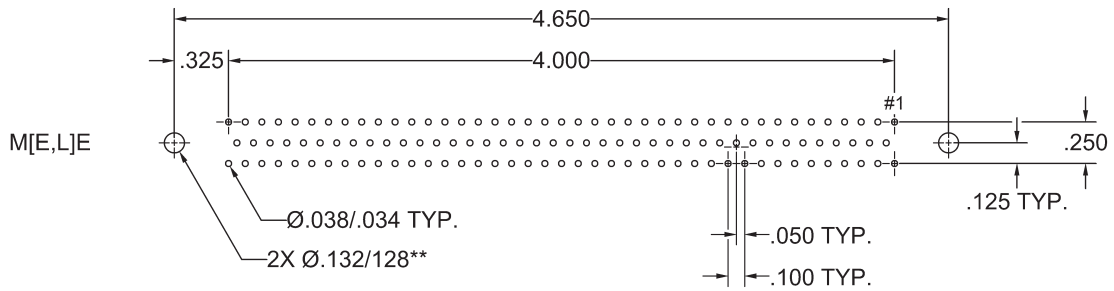
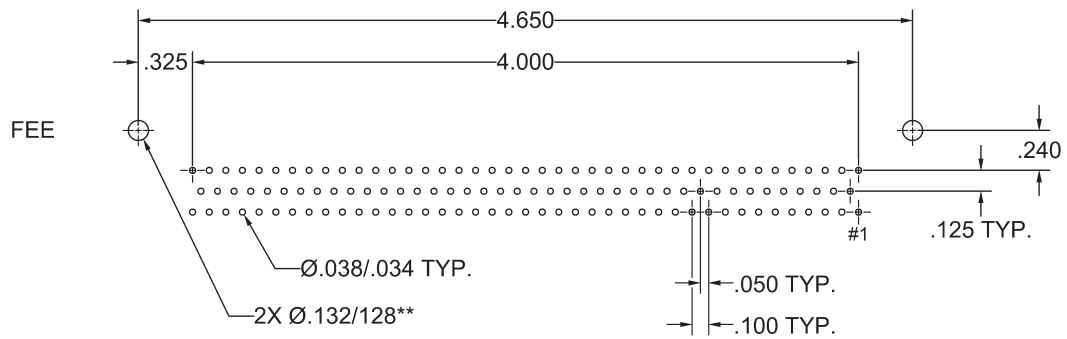
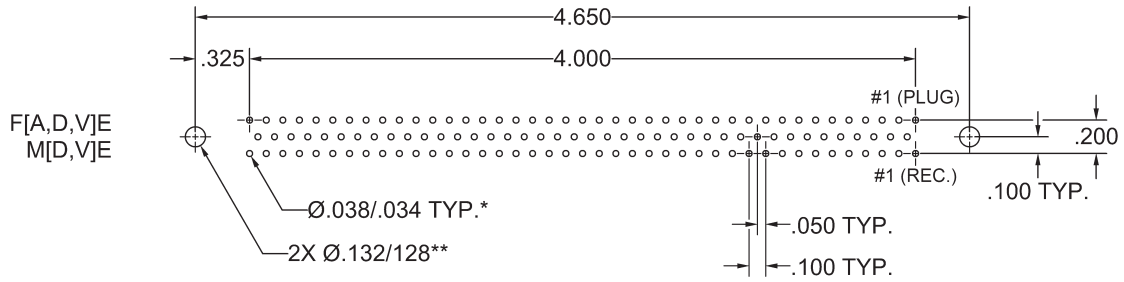

\*.042/.038 RECOMMENDED HOLE SIZE FOR COMPLIANT TERMINATION STYLE CONTACTS. FOR ALL OTHERS, HOLE SIZE SUBJECT TO USER MODIFICATION FOR APPLICATION OR ALTERNATIVE STANDARDS.

\*\*RECOMMENDATION. MAY BE MODIFIED FOR APPLICATION OR ALTERNATIVE STANDARDS.

**PWB PATTERN - 3 ROW**  
**160**  
**AS VIEWED FROM THE COMPONENT SIDE**

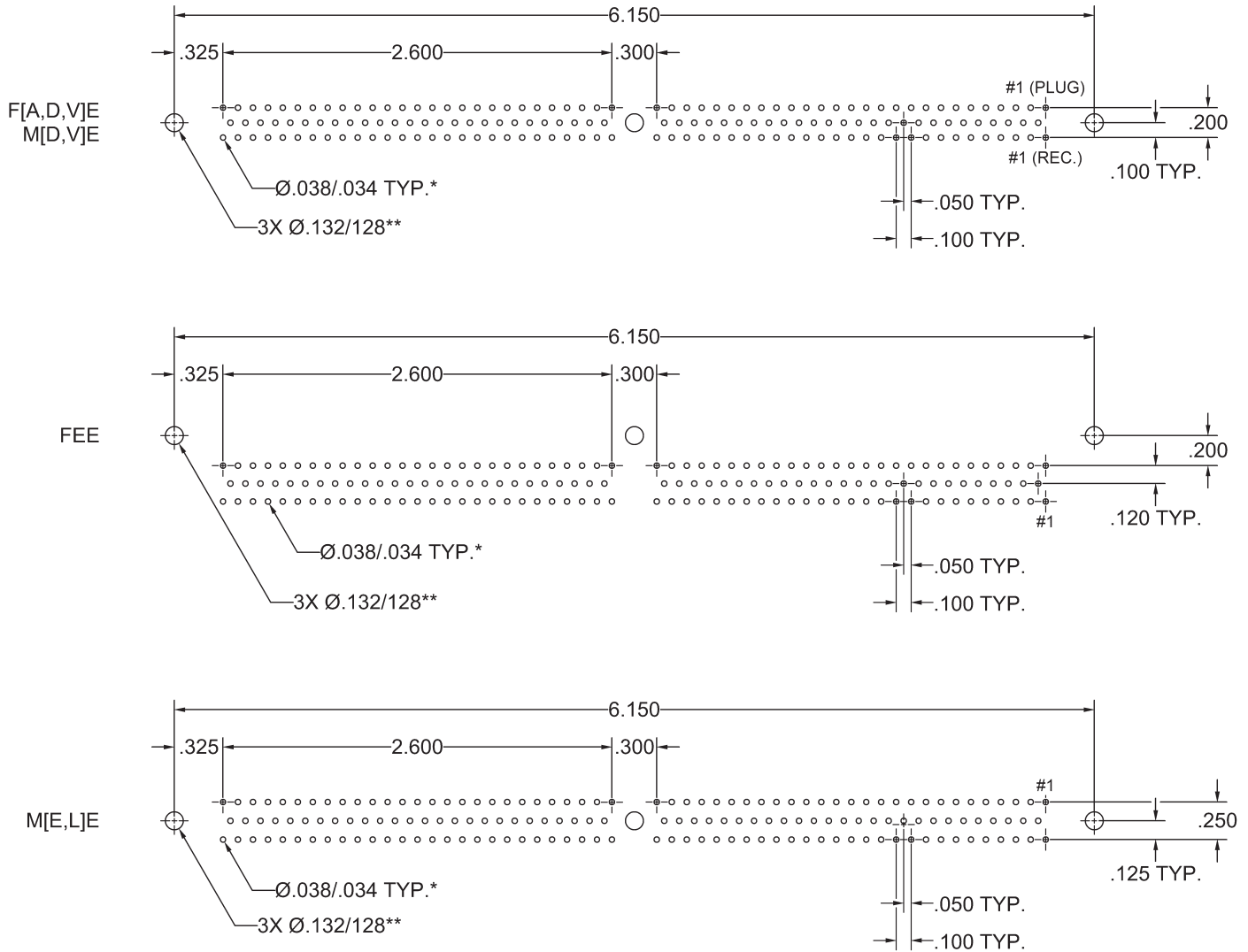

\*.042/.038 RECOMMENDED HOLE SIZE FOR COMPLIANT TERMINATION STYLE CONTACTS.. FOR ALL OTHERS, HOLE SIZE SUBJECT TO USER MODIFICATION FOR APPLICATION OR ALTERNATIVE STANDARDS.

\*\*RECOMMENDATION. MAY BE MODIFIED FOR APPLICATION OR ALTERNATIVE STANDARDS.

**PWB PATTERN - 3 ROW**  
**208**  
**AS VIEWED FROM THE COMPONENT SIDE**

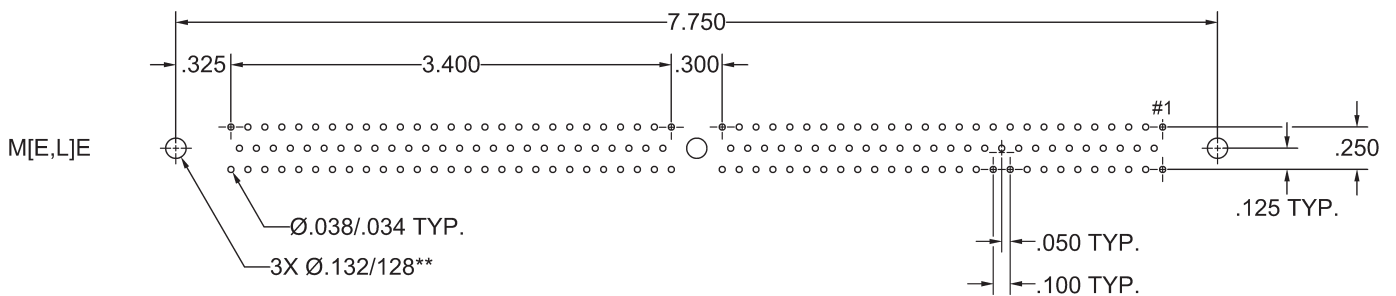
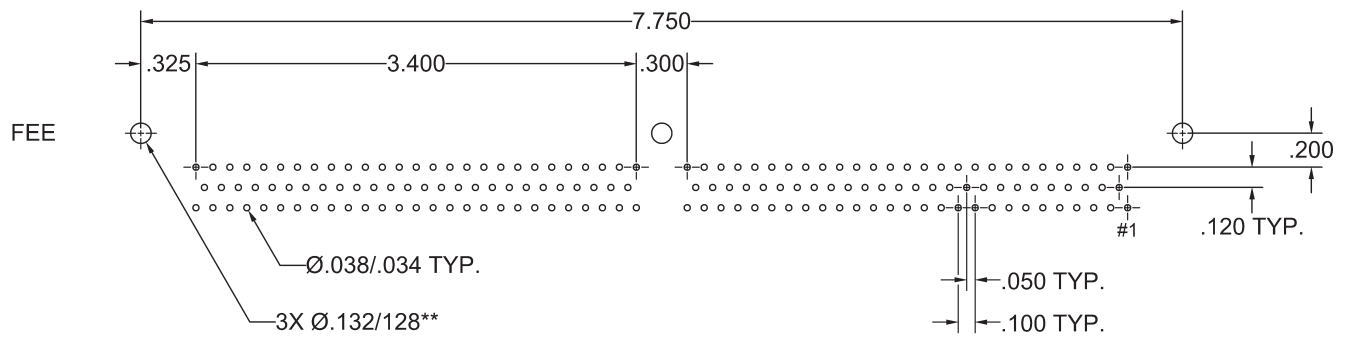
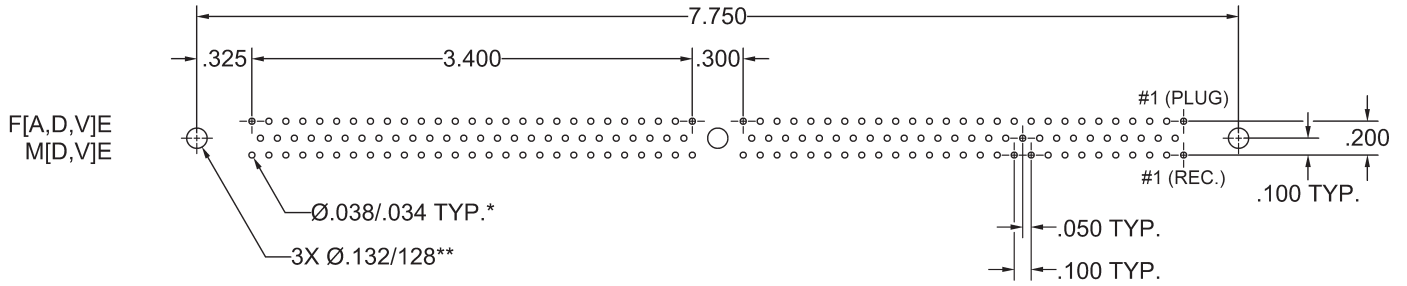

\*.042/.038 RECOMMENDED HOLE SIZE FOR COMPLIANT TERMINATION STYLE CONTACTS. FOR ALL OTHERS, HOLE SIZE SUBJECT TO USER MODIFICATION FOR APPLICATION OR ALTERNATIVE STANDARDS.

\*\*RECOMMENDATION. MAY BE MODIFIED FOR APPLICATION OR ALTERNATIVE STANDARDS.



## **IEH CORPORATION**

140 58TH STREET, 8E, BROOKLYN, NY 11220

PHONE (718) 492-4448 • FAX (718) 492-9898

[www.iehcorp.com](http://www.iehcorp.com) • [ieh@iehcorp.com](mailto:ieh@iehcorp.com)